

# Technical Support Center: Overcoming PDE5 Inhibitor Resistance in Research

**Author:** BenchChem Technical Support Team. **Date:** December 2025

## Compound of Interest

Compound Name: Pde5-IN-5

Cat. No.: B12419604

[Get Quote](#)

This guide provides troubleshooting strategies and detailed protocols for researchers encountering resistance or non-response to Phosphodiesterase 5 (PDE5) inhibitors in pre-clinical research models.

## Section 1: Frequently Asked Questions (FAQs)

Q1: What are the primary mechanisms of PDE5 inhibitor resistance in research models?

A1: Resistance to PDE5 inhibitors in research models typically stems from disruptions at one or more points within the Nitric Oxide (NO)-cyclic Guanosine Monophosphate (cGMP) signaling pathway. The most common mechanisms are:

- **Impaired NO Production:** Insufficient synthesis of NO by endothelial nitric oxide synthase (eNOS) due to factors like limited substrate (L-arginine), cofactor deficiency, or eNOS uncoupling.
- **Soluble Guanylate Cyclase (sGC) Dysfunction:** The enzyme sGC, which synthesizes cGMP in response to NO, can become desensitized or dysfunctional. Sustained high levels of NO can lead to S-nitrosylation of sGC, reducing its responsiveness<sup>[1][2][3][4]</sup>. Oxidative stress can also impair sGC function<sup>[5][6]</sup>.
- **PDE5 Upregulation:** Chronic exposure to elevated NO or cGMP can lead to a compensatory increase in PDE5 expression and activity, effectively creating a negative feedback loop that dampens the signal<sup>[7]</sup>.

- **Dominance of Contractile Pathways:** Over-activation of counter-regulatory vasoconstrictor pathways, most notably the RhoA/Rho-kinase (ROCK) pathway, can functionally override the smooth muscle relaxation signals produced by cGMP[8][9].

Q2: My PDE5 inhibitor shows no effect in my tissue bath experiment. How can I begin to troubleshoot this?

A2: A lack of response in a tissue bath (e.g., aortic ring) assay is a common issue. A logical troubleshooting workflow should be followed:

- **Confirm Endothelium Integrity:** Test the ability of the tissue to relax in response to an endothelium-dependent vasodilator like acetylcholine (ACh). A robust relaxation to ACh confirms that the endothelium is healthy and capable of producing NO. If there is no response, the tissue may have been damaged during preparation.
- **Test Downstream of NO:** If the tissue responds poorly to ACh, use an NO donor like sodium nitroprusside (SNP). A strong relaxation response to SNP indicates that the soluble guanylate cyclase (sGC) and downstream machinery in the smooth muscle are functional, pointing to a problem with endothelial NO production.
- **Verify PDE5 Activity:** If the tissue relaxes with SNP, it confirms the presence of a functional cGMP-dependent relaxation mechanism. Pre-incubating the tissue with your PDE5 inhibitor should potentiate the relaxation caused by a sub-maximal dose of SNP. If it doesn't, this could suggest a problem with the inhibitor itself (e.g., degradation, incorrect concentration) or extremely high levels of PDE5 expression.

Q3: My cell-based assay shows no increase in cGMP levels after applying an NO donor and a PDE5 inhibitor. What are the potential causes?

A3: Failure to detect an increase in intracellular cGMP can be due to several factors:

- **Cell Health and Confluency:** Ensure cells are healthy, within a proper passage number, and not overly confluent, which can alter signaling responses. Basic issues like microbial contamination or media degradation should be ruled out.
- **sGC Dysfunction:** The cell line may have low expression or dysfunctional sGC. This is a known issue in some cell types or can be induced by oxidative stress[5][6].

- **Rapid cGMP Efflux:** Some cells actively transport cGMP out of the cell via transporters like MRP5 (ABCC5). The rate of efflux may be too high to allow for accumulation, even with PDE5 inhibition.
- **Assay Sensitivity:** Ensure your cGMP detection method (e.g., ELISA) is sensitive enough for the expected concentrations and that the cell lysis and sample preparation steps (e.g., acidification with HCl) were performed correctly to halt phosphodiesterase activity[10].
- **Low Basal cGMP:** If basal cGMP levels are extremely low, the effect of a PDE5 inhibitor alone may be undetectable. An NO donor is typically required to stimulate cGMP production, which can then be protected by the inhibitor[11][12].

Q4: What is the RhoA/ROCK pathway, and how does it contribute to PDE5 inhibitor resistance?

A4: The RhoA/ROCK pathway is a major signaling cascade that promotes smooth muscle contraction. It acts as a physiological antagonist to the NO/cGMP relaxation pathway. The key mechanism is the inhibition of myosin light chain phosphatase (MLCP). By inhibiting MLCP, the ROCK enzyme increases the phosphorylation level of the myosin light chain, leading to Ca<sup>2+</sup> sensitization and sustained contraction[8][13]. In disease models or under certain stimuli, this pathway can become upregulated, creating a dominant contractile tone that PDE5 inhibitors cannot overcome. Therefore, even with elevated cGMP levels, the tissue or cells may fail to relax if the RhoA/ROCK pathway is hyperactive[9][14].

## Section 2: Troubleshooting Guides

### Guide 1: Poor or No Response in Vascular Ring Assays

Observed Problem	Potential Cause	Suggested Action & Rationale
No relaxation to Acetylcholine (ACh).	Endothelial damage during preparation.	Discard tissue. Review dissection and mounting protocol to minimize damage to the intimal surface. The endothelium is required for endogenous NO production.
No relaxation to ACh, but strong relaxation to Sodium Nitroprusside (SNP).	Impaired endothelial NO synthase (eNOS) function.	The model may have endothelial dysfunction. This is a valid finding. Proceed with experiments using NO donors to directly test smooth muscle responses.
No relaxation to either ACh or SNP.	Smooth muscle damage or non-functional sGC/PKG pathway.	Discard tissue. Check viability of the tissue source. Ensure Krebs solution is correctly prepared, oxygenated, and at the correct temperature.
Tissue responds to SNP, but pre-incubation with PDE5i does not enhance SNP-induced relaxation.	1. Inactive inhibitor.2. Extremely high PDE5 expression.3. Dominant contractile signaling.	1. Prepare fresh inhibitor stock. Confirm purity and correct storage.2. Perform Western blot to quantify PDE5 protein levels in the tissue.3. Test for involvement of the RhoA/ROCK pathway by adding a ROCK inhibitor (e.g., Y-27632). If relaxation is restored, it indicates a dominant contractile pathway.

## Guide 2: Inconsistent or Low cGMP Readouts in Cell Culture

Observed Problem	Potential Cause	Suggested Action & Rationale
High variability between replicate wells.	Uneven cell plating; inconsistent cell health.	Review cell counting and plating technique to ensure a uniform monolayer. Use cells from the same passage number for all experiments.
Low cGMP levels even with NO donor + PDE5i.	1. Inefficient cell lysis/sample prep. 2. Low sGC expression/activity. 3. High cGMP efflux.	1. Ensure lysis buffer (typically 0.1M HCl) is added quickly and cells are fully lysed to immediately stop all PDE activity[10]. 2. Confirm sGC subunit expression via Western blot or qPCR. Test different, more potent NO donors. 3. Consider using an efflux pump inhibitor if one is known to be active in your cell type.
Basal cGMP is undetectable.	This is normal for many cell types.	PDE5 inhibitors work by preventing the breakdown of cGMP. If there is no stimulus to produce cGMP (like an NO donor), there will be little to no substrate for the inhibitor to protect. Always include a positive control with an NO donor.

## Section 3: Key Experimental Protocols

### Protocol 1: Assessment of Vasorelaxation in Aortic Rings

This protocol describes a standard method for assessing the effect of PDE5 inhibitors on isolated rat aortic rings.

- Tissue Preparation:
  - Humanely euthanize a rat and immediately excise the thoracic aorta.
  - Place the aorta in cold Krebs-Henseleit buffer (Composition in mM: NaCl 118, KCl 4.7, CaCl<sub>2</sub> 2.5, KH<sub>2</sub>PO<sub>4</sub> 1.2, MgSO<sub>4</sub> 1.2, NaHCO<sub>3</sub> 25, Glucose 11.1).
  - Carefully clean the aorta of adhering fat and connective tissue and cut it into 3-4 mm wide rings[15]. For endothelium-denuded rings, gently rub the inner surface with a fine wire or forceps[15][16][17].
- Mounting:
  - Suspend each ring between two L-shaped stainless steel hooks in a 15 mL organ bath filled with Krebs buffer, maintained at 37°C and continuously bubbled with 95% O<sub>2</sub> / 5% CO<sub>2</sub>[15][18].
  - Connect the upper hook to an isometric force transducer linked to a data acquisition system.
- Equilibration and Viability Check:
  - Allow the rings to equilibrate for 60-90 minutes under a resting tension of 2 g, washing with fresh Krebs buffer every 15-20 minutes[15].
  - Induce contraction with phenylephrine (PE, 1 μM). Once the contraction plateaus, add acetylcholine (ACh, 10 μM) to test endothelium integrity. Rings showing >80% relaxation are considered endothelium-intact. Wash the rings and allow them to return to baseline.
- Experimental Procedure:
  - Pre-contract the rings again with phenylephrine (1 μM).
  - Once a stable contraction is achieved, add your PDE5 inhibitor (e.g., Sildenafil, 10<sup>-9</sup> to 10<sup>-5</sup> M) in a cumulative concentration-response manner, allowing the response to stabilize

at each concentration[18][19].

- Record the relaxation as a percentage of the maximal PE-induced contraction.

## Protocol 2: Measurement of Intracellular cGMP by ELISA

This protocol is for quantifying cGMP in cultured cells (e.g., vascular smooth muscle cells).

- Cell Culture: Plate cells in 24-well plates and grow to ~90% confluency.
- Pre-incubation: Wash cells once with serum-free media or a buffered salt solution (e.g., HBSS). Add media containing the PDE5 inhibitor at the desired concentration (or vehicle control) and incubate for 30 minutes.
- Stimulation: Add an NO donor (e.g., SNP, 100  $\mu$ M) to the wells and incubate for the desired time (e.g., 10-15 minutes).
- Lysis: Aspirate the media and immediately add 200  $\mu$ L of cold 0.1M HCl to each well to lyse the cells and stop all enzymatic activity. Incubate on ice for 10 minutes[10].
- Sample Collection: Scrape the cells and transfer the acidic lysate to a microcentrifuge tube. Centrifuge at >13,000 g for 5 minutes to pellet cell debris[10].
- ELISA:
  - Use the supernatant for the cGMP measurement.
  - Follow the manufacturer's instructions for your specific competitive cGMP ELISA kit (e.g., Abcam ab133052, Enzo Life Sciences)[10]. This typically involves adding samples, a cGMP-alkaline phosphatase conjugate, and a specific antibody to a pre-coated plate.
  - The colorimetric reaction is inversely proportional to the amount of cGMP in the sample.
  - Calculate cGMP concentration based on the standard curve and normalize to the total protein content of a parallel well, if necessary.

## Protocol 3: Western Blot for Key Pathway Proteins

This protocol allows for the quantification of eNOS, sGC, and PDE5 protein expression.

- **Sample Preparation:** Homogenize tissues or lyse cells in RIPA buffer containing protease and phosphatase inhibitors. Determine total protein concentration using a BCA or Bradford assay.
- **SDS-PAGE:** Load 20-30 µg of total protein per lane onto a 4-12% Bis-Tris polyacrylamide gel and separate by electrophoresis[7].
- **Transfer:** Transfer the separated proteins to a PVDF or nitrocellulose membrane.
- **Blocking and Antibody Incubation:**
  - Block the membrane for 1 hour at room temperature with 5% non-fat dry milk or BSA in Tris-buffered saline with 0.1% Tween-20 (TBST).
  - Incubate with a primary antibody specific for your target protein (e.g., anti-eNOS, anti-sGCβ1, anti-PDE5) overnight at 4°C, following the manufacturer's recommended dilution[7][20][21].
  - Wash the membrane 3 times with TBST.
  - Incubate with an appropriate HRP-conjugated secondary antibody for 1 hour at room temperature.
- **Detection:**
  - Wash the membrane 3 times with TBST.
  - Apply an enhanced chemiluminescence (ECL) substrate and visualize the bands using a digital imager or X-ray film.
- **Analysis:** Quantify band density using software like ImageJ. Normalize the signal of the target protein to a loading control like α-actin or GAPDH to correct for differences in protein loading[7][22].

## Section 4: Data Presentation & Signaling Pathways

### Quantitative Data Summary



Table 1: IC50 Values of Common PDE5 Inhibitors This table shows the concentration of inhibitor required to reduce the activity of the PDE5 enzyme by 50% in vitro. Lower values indicate higher potency.

Inhibitor	PDE5 IC50 (nM)
Vardenafil	0.1 - 0.4
Tadalafil	2.0
Sildenafil	4.0
Avanafil	4.3 - 5.2
Data compiled from[23]	

Table 2: Example Vasorelaxation Data for Sildenafil on Rat Aortic Rings This table presents typical maximum relaxation (%) induced by a high concentration ( $10^{-4}$  M) of Sildenafil on phenylephrine-precontracted rat aortic rings.

Tissue Condition	Maximum Relaxation (%)
Endothelium-Intact	96%
Endothelium-Denuded	79%
Data represents findings from studies such as[15][16][17], demonstrating both endothelium-dependent and independent effects.	

## Signaling Pathway Diagrams

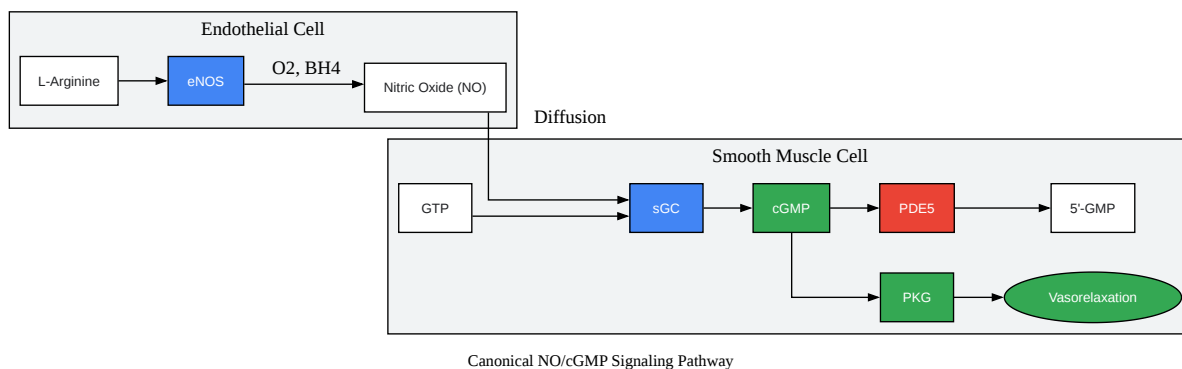

[Click to download full resolution via product page](#)

Caption: The canonical NO/cGMP pathway leading to smooth muscle relaxation.

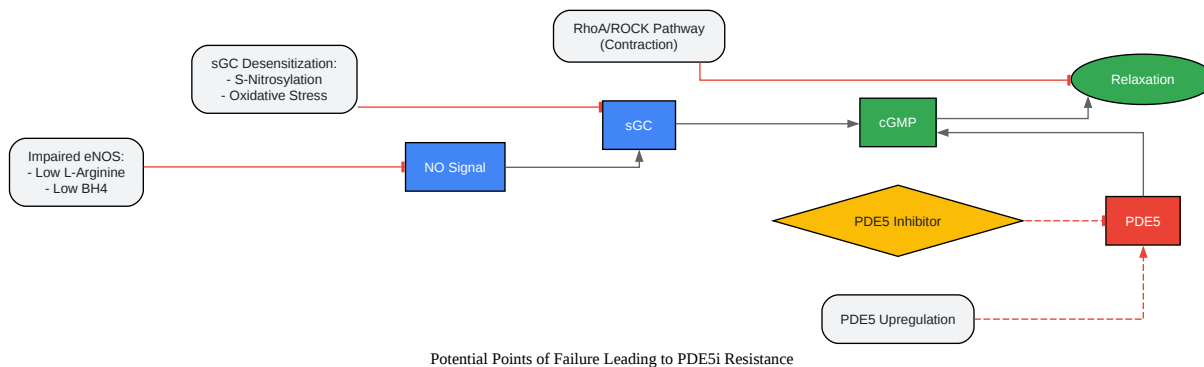

[Click to download full resolution via product page](#)

Caption: Key mechanisms that can cause resistance to PDE5 inhibitors.

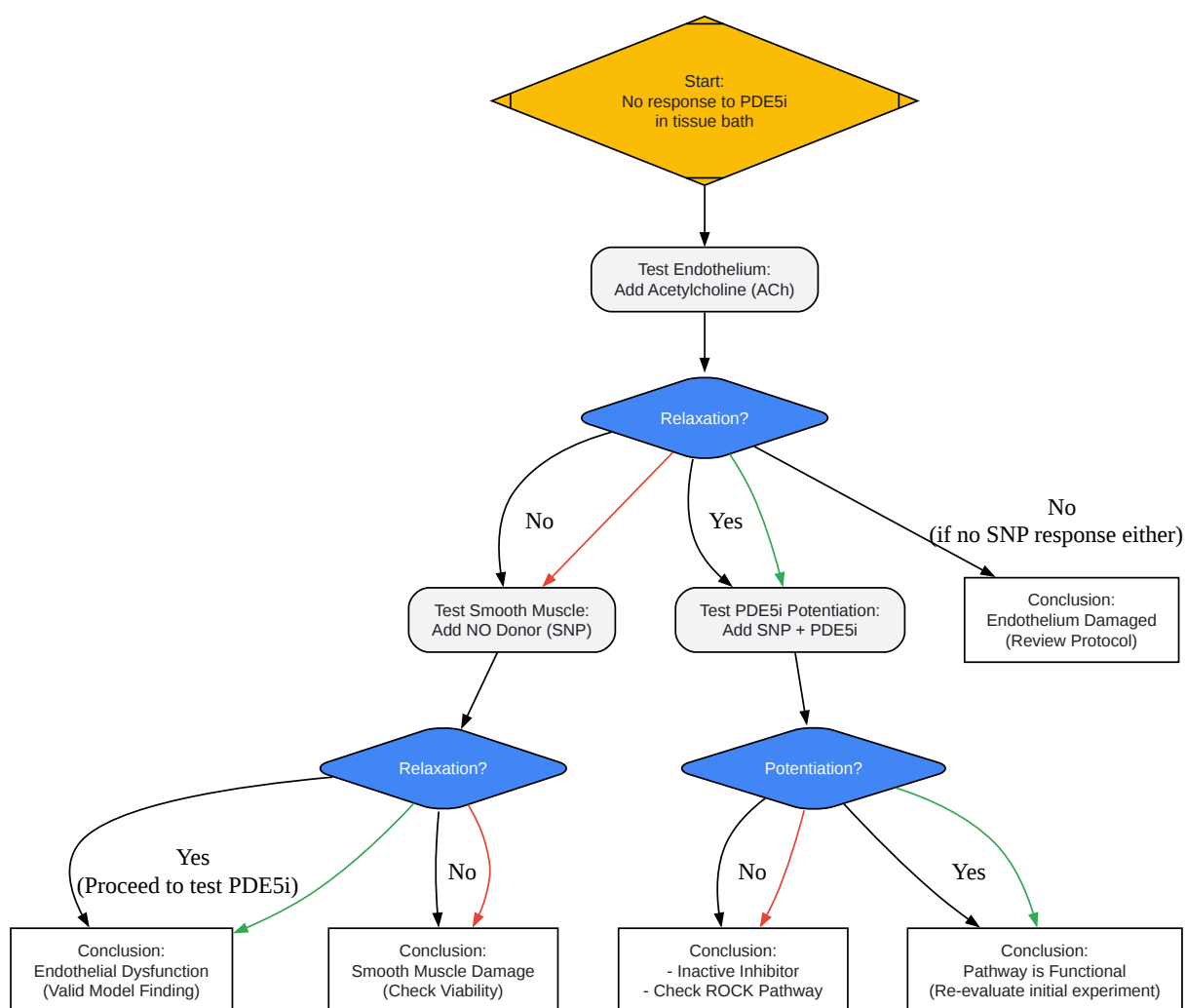

[Click to download full resolution via product page](#)

Caption: A logical workflow for troubleshooting failed vasorelaxation experiments.

### **Need Custom Synthesis?**

*BenchChem offers custom synthesis for rare earth carbides and specific isotopic labeling.*

*Email: [info@benchchem.com](mailto:info@benchchem.com) or [Request Quote Online](#).*

## References

- 1. [pnas.org](https://pnas.org) [[pnas.org](https://pnas.org)]
- 2. [scispace.com](https://scispace.com) [[scispace.com](https://scispace.com)]
- 3. Desensitization of soluble guanylyl cyclase, the NO receptor, by S-nitrosylation - PubMed [[pubmed.ncbi.nlm.nih.gov](https://pubmed.ncbi.nlm.nih.gov)]
- 4. [researchgate.net](https://researchgate.net) [[researchgate.net](https://researchgate.net)]
- 5. Frontiers | Rethinking of phosphodiesterase 5 inhibition: the old, the new and the perspective in human health [[frontiersin.org](https://frontiersin.org)]
- 6. Rethinking of phosphodiesterase 5 inhibition: the old, the new and the perspective in human health - PMC [[pmc.ncbi.nlm.nih.gov](https://pmc.ncbi.nlm.nih.gov)]
- 7. Induction of PDE5 and de-sensitization to endogenous NO signaling in a systemic resistance artery under altered blood flow - PMC [[pmc.ncbi.nlm.nih.gov](https://pmc.ncbi.nlm.nih.gov)]
- 8. [tandfonline.com](https://tandfonline.com) [[tandfonline.com](https://tandfonline.com)]
- 9. Role of Rho/Rho-kinase and NO/cGMP signaling pathways in vascular function prior to atherosclerosis - PubMed [[pubmed.ncbi.nlm.nih.gov](https://pubmed.ncbi.nlm.nih.gov)]
- 10. [tandfonline.com](https://tandfonline.com) [[tandfonline.com](https://tandfonline.com)]
- 11. [ahajournals.org](https://ahajournals.org) [[ahajournals.org](https://ahajournals.org)]
- 12. It takes two to tango: cardiac fibroblast-derived NO-induced cGMP enters cardiac myocytes and increases cAMP by inhibiting PDE3 - PMC [[pmc.ncbi.nlm.nih.gov](https://pmc.ncbi.nlm.nih.gov)]
- 13. [oaepublish.com](https://oaepublish.com) [[oaepublish.com](https://oaepublish.com)]
- 14. Roles of the RhoA-ROCK Signaling Pathway in the Endothelial H<sub>2</sub>S Production and Vasodilation in Rat Cerebral Arteries - PMC [[pmc.ncbi.nlm.nih.gov](https://pmc.ncbi.nlm.nih.gov)]
- 15. [article.imrpress.com](https://article.imrpress.com) [[article.imrpress.com](https://article.imrpress.com)]

- 16. scialert.net [scialert.net]
- 17. Vasorelaxant Effects of Sildenafil and Verapamil on Isolated Rat Aorta With and Without Intact Endothelium [gcris.yyu.edu.tr]
- 18. Vasorelaxant Effect of Sildenafil on Aorta and Pulmonary Artery in Rabbits [imrpress.com]
- 19. Effect of sildenafil on the isolated rat aortic rings - PubMed [pubmed.ncbi.nlm.nih.gov]
- 20. Expression of cGMP-binding cGMP-specific phosphodiesterase (PDE5) in mouse tissues and cell lines using an antibody against the enzyme amino-terminal domain - PubMed [pubmed.ncbi.nlm.nih.gov]
- 21. researchgate.net [researchgate.net]
- 22. researchgate.net [researchgate.net]
- 23. Advancements in Phosphodiesterase 5 Inhibitors: Unveiling Present and Future Perspectives - PMC [pmc.ncbi.nlm.nih.gov]
- To cite this document: BenchChem. [Technical Support Center: Overcoming PDE5 Inhibitor Resistance in Research]. BenchChem, [2025]. [Online PDF]. Available at: [https://www.benchchem.com/product/b12419604#overcoming-resistance-to-pde5-inhibitors-in-research-models]

---

#### Disclaimer & Data Validity:

The information provided in this document is for Research Use Only (RUO) and is strictly not intended for diagnostic or therapeutic procedures. While BenchChem strives to provide accurate protocols, we make no warranties, express or implied, regarding the fitness of this product for every specific experimental setup.

**Technical Support:** The protocols provided are for reference purposes. Unsure if this reagent suits your experiment? [[Contact our Ph.D. Support Team for a compatibility check](#)]

**Need Industrial/Bulk Grade?** [Request Custom Synthesis Quote](#)

# BenchChem

Our mission is to be the trusted global source of essential and advanced chemicals, empowering scientists and researchers to drive progress in science and industry.

## Contact

Address: 3281 E Guasti Rd

Ontario, CA 91761, United States

Phone: (601) 213-4426

Email: [info@benchchem.com](mailto:info@benchchem.com)