

SOS1 Degradер Development: A Technical Support Guide

Author: BenchChem Technical Support Team. **Date:** April 2026

Compound of Interest

Compound Name: PROTAC SOS1 degrader-2

Cat. No.: B12419217

[Get Quote](#)

Prepared by the Gemini Senior Application Scientist Team

Welcome to the technical support center for the clinical development of Son of Sevenless homolog 1 (SOS1) degraders. This guide is designed for researchers, scientists, and drug development professionals actively working in the field of targeted protein degradation. As pioneers in a rapidly evolving field, you will encounter unique experimental challenges. This resource provides in-depth, field-proven insights in a direct question-and-answer format to help you navigate these hurdles, troubleshoot common issues, and validate your findings with scientific rigor.

Section 1: Frequently Asked Questions (FAQs)

This section addresses high-level conceptual and strategic questions that form the foundation of a successful SOS1 degrader program.

Q1: What is the fundamental mechanism of action for an SOS1 degrader?

An SOS1 degrader is a heterobifunctional molecule, often a Proteolysis-Targeting Chimera (PROTAC), designed to eliminate the SOS1 protein from the cell.[1] It consists of three key

components: a "warhead" that binds to SOS1, an E3 ligase-recruiting ligand (e.g., for Cereblon [CRBN] or Von Hippel-Lindau [VHL]), and a chemical linker connecting the two.[1][2]

The degrader works by acting as a molecular bridge, bringing SOS1 into close proximity with the recruited E3 ubiquitin ligase.[1] This induced proximity facilitates the formation of a ternary complex (SOS1-Degrader-E3 Ligase), which allows the E3 ligase to tag SOS1 with a chain of ubiquitin molecules.[1] This polyubiquitination marks SOS1 for recognition and subsequent destruction by the 26S proteasome, the cell's primary protein disposal machinery.[3][4]

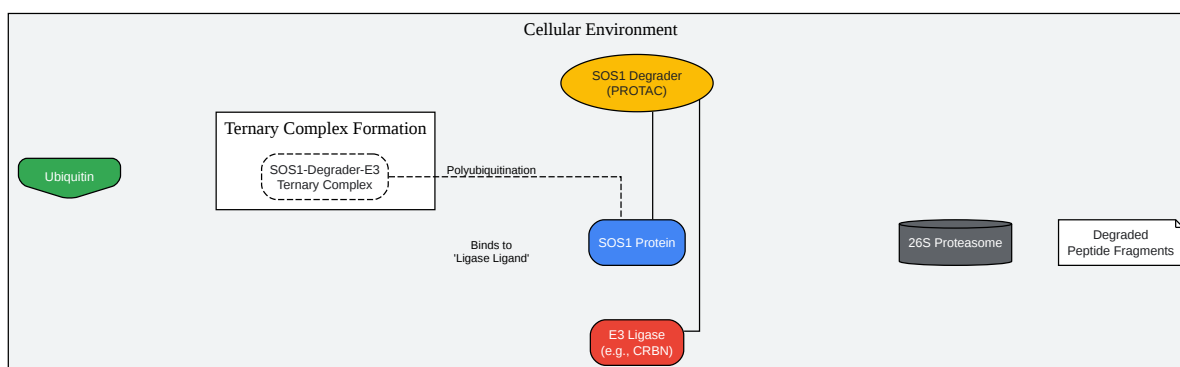

[Click to download full resolution via product page](#)

Caption: Mechanism of Action for a SOS1 Degrader.

Q2: Why pursue an SOS1 degrader over a small molecule inhibitor?

While SOS1 inhibitors effectively block the protein's guanine nucleotide exchange factor (GEF) activity, degraders offer several potential advantages that are critical for clinical development:

- **Elimination of Scaffolding Functions:** SOS1 acts as a scaffold for other proteins in signaling pathways. An inhibitor only blocks its enzymatic function, leaving the protein intact to perform non-catalytic roles. Degraders, by removing the entire protein, abrogate both enzymatic and scaffolding functions, which can lead to a more profound and durable pathway inhibition.[5]
- **Superior Potency and Duration:** Because degraders act catalytically—one molecule can induce the degradation of multiple target proteins—they can achieve a biological effect at much lower concentrations than inhibitors, which require stoichiometric occupancy.[5] The long half-life of the SOS1 protein (>18 hours) means that even transient exposure to a degrader can lead to a sustained loss of the target, potentially allowing for less frequent dosing.[6]
- **Overcoming Resistance:** Tumors can develop resistance to inhibitors through mutations in the drug-binding site. Degraders may still be effective as long as sufficient binding affinity is maintained to form the ternary complex. Furthermore, degraders have shown superior antitumor activity compared to their corresponding inhibitor warheads in preclinical models. [5][7][8]
- **Improved Selectivity:** The requirement to form a stable ternary complex with a specific E3 ligase can impose an additional layer of specificity, potentially leading to fewer off-target effects compared to an inhibitor warhead alone.[2]

Q3: How do I select the appropriate E3 ligase ligand (e.g., CRBN vs. VHL) for my SOS1 degrader?

The choice between Cereblon (CRBN) and Von Hippel-Lindau (VHL) ligands is a critical design decision. There is no universal "best" choice; the optimal E3 ligase depends on the specific target and cellular context.

- **Ligand Availability and Tractability:** Both CRBN (using thalidomide-like ligands) and VHL have well-characterized, high-affinity small molecule ligands that are synthetically tractable. [9]
- **Tissue Expression and Biology:** Consider the expression levels of CRBN and VHL in your target tissues. The abundance of the E3 ligase can directly impact degradation efficiency.

- Ternary Complex Geometry: The ultimate driver of degradation is the formation of a "productive" ternary complex where ubiquitin can be efficiently transferred to SOS1. The relative orientation and surfaces of SOS1 and the E3 ligase are key. It is often necessary to empirically test both CRBN- and VHL-based degraders to determine which allows for more favorable complex formation.^[9] Several successful preclinical SOS1 degraders have utilized CRBN ligands.^{[3][5][7][10]}

Section 2: Troubleshooting Guide

This section provides solutions to specific experimental problems in a structured, cause-and-effect format.

Problem: My SOS1 degrader shows low potency (high DC₅₀) or no degradation.

A lack of potent degradation is a common early-stage challenge. A systematic approach is required to pinpoint the failure point.

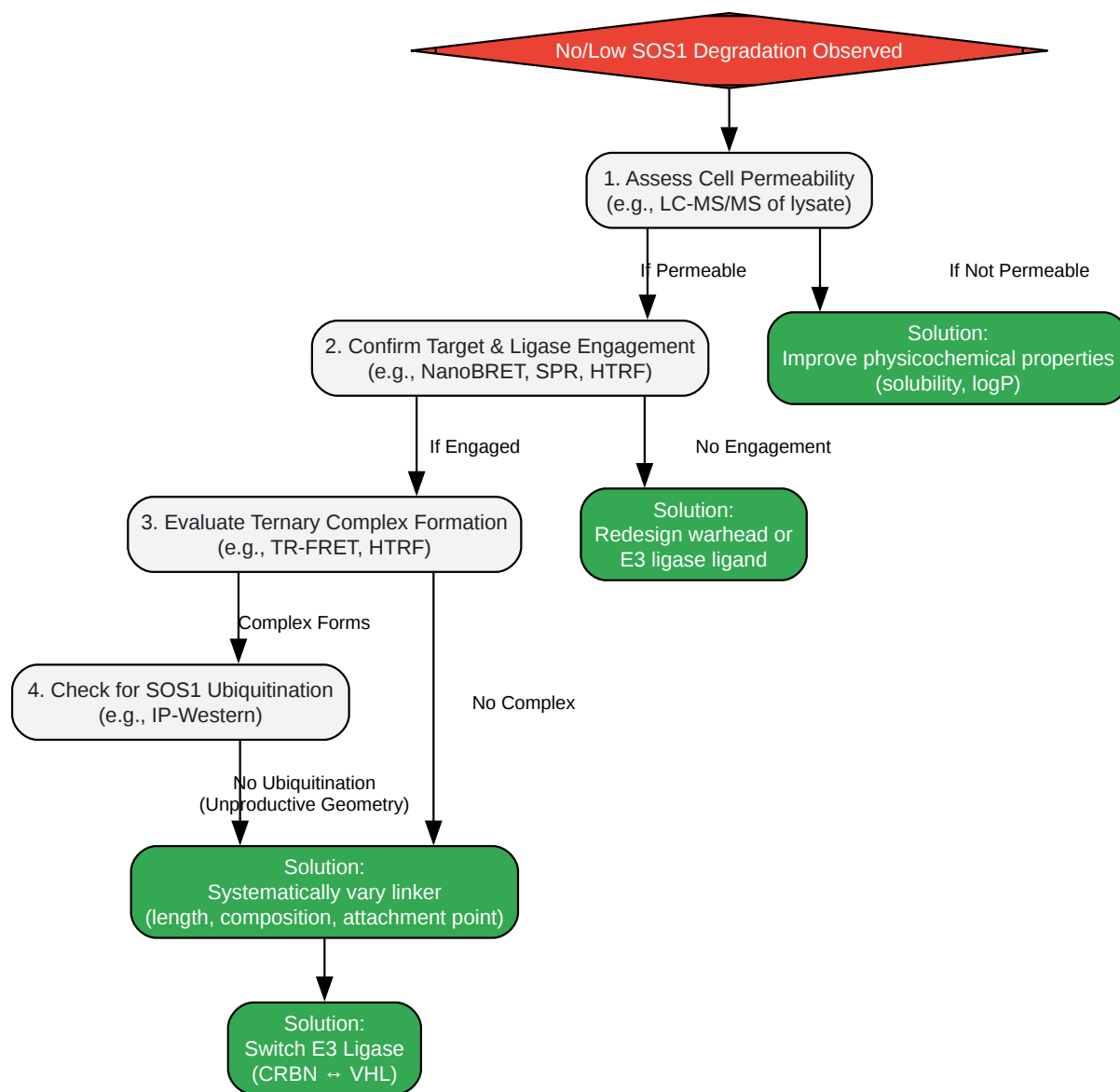

[Click to download full resolution via product page](#)

Caption: Troubleshooting Workflow for Ineffective SOS1 Degraders.

- Potential Cause 1: Poor Compound Properties. The degrader may not be sufficiently soluble or permeable to reach its intracellular target.

- Troubleshooting Step: Use LC-MS/MS to measure the intracellular concentration of your compound.
- Potential Cause 2: Insufficient Target or E3 Ligase Engagement. The warhead or E3 ligase ligand may have low affinity in the cellular environment.
 - Troubleshooting Step: Confirm binary engagement of your degrader with both SOS1 and the E3 ligase separately using biophysical assays like Surface Plasmon Resonance (SPR) or cellular target engagement assays like NanoBRET.[11][12]
- Potential Cause 3: Inefficient Ternary Complex Formation. Even with good binary affinities, the linker may not be optimal to support a stable and productive ternary complex. The "cooperativity" of the complex is crucial.[13]
 - Troubleshooting Step: Use biophysical assays like TR-FRET or HTRF to directly measure ternary complex formation in the presence of the degrader, SOS1, and the E3 ligase complex.[11][13] The most common solution is to systematically redesign the linker, varying its length, rigidity, and attachment points.[9][13][14]
- Potential Cause 4: Unproductive Ternary Complex Geometry. A ternary complex may form, but it may not position a lysine residue on SOS1 correctly for ubiquitination by the E3 ligase.
 - Troubleshooting Step: Perform an in-cell ubiquitination assay by immunoprecipitating SOS1 and blotting for ubiquitin after treatment. If no ubiquitination is observed despite complex formation, it points to a geometry problem.[12] This often requires a linker redesign or switching the E3 ligase recruiter (e.g., from CRBN to VHL).[15]

Problem: I am observing a "hook effect" with my degrader.

The "hook effect" is a classic phenomenon in PROTAC research where degradation efficiency decreases at higher compound concentrations.[9][15]

- Cause: At excessive concentrations, the degrader is more likely to form separate binary complexes (Degradation-SOS1 and Degradation-E3 Ligase) rather than the productive ternary complex.[2][9] This saturation of the binding sites prevents the "bridging" required for degradation.

- Solution:
 - Perform a Wide Dose-Response: Always test your degrader over a broad concentration range (e.g., from low nanomolar to high micromolar) to fully characterize the dose-response curve and identify the optimal concentration window for maximal degradation (DC_{max}).[\[9\]](#)[\[15\]](#)
 - Focus on the "Sweet Spot": Subsequent experiments should be performed at or near the optimal degradation concentration.
 - Enhance Cooperativity: In the design phase, aim for degraders that promote positive cooperativity, which stabilizes the ternary complex over the binary ones, potentially widening the effective concentration window.[\[15\]](#)

Problem: My degrader is causing significant off-target protein degradation.

Selectivity is paramount for clinical success. Off-target degradation can lead to unforeseen toxicity.

- Cause 1: Non-selective Warhead. The SOS1-binding portion of your degrader may have affinity for other proteins.
- Cause 2: Bystander Degradation. The induced ternary complex may be "sloppy," leading to the ubiquitination of proteins that interact with SOS1 or the E3 ligase.[\[2\]](#)
- Cause 3: CRBN Neosubstrate Degradation. CRBN-based degraders can sometimes induce degradation of known CRBN neosubstrates, such as GSPT1, IKZF1, and IKZF3.[\[4\]](#)[\[5\]](#) A highly specific degrader should minimize this.[\[4\]](#)[\[5\]](#)
- Troubleshooting and Validation:
 - Global Proteomics: The gold standard for assessing selectivity is unbiased mass spectrometry-based proteomics.[\[5\]](#) Treat cells with your degrader at its optimal concentration for a short duration (e.g., 6-8 hours) to identify direct degradation targets before downstream signaling changes occur.[\[14\]](#)[\[16\]](#)

- Warhead Optimization: If off-targets are identified, consider redesigning the warhead for improved selectivity.
- Linker and E3 Ligase Modification: Systematically altering the linker or switching the E3 ligase can change the geometry of the ternary complex and improve the selectivity profile. [\[15\]](#)

Problem: SOS1 protein levels rebound quickly, or the cells develop resistance.

Even after successful degradation, cells can employ compensatory mechanisms.

- Cause: Cells may adapt to the loss of SOS1 by increasing the transcription of the SOS1 gene or its homolog, SOS2. [\[5\]](#)[\[17\]](#) This feedback mechanism attempts to restore protein homeostasis.
- Troubleshooting and Investigation:
 - Measure mRNA Levels: Use qPCR to measure SOS1 and SOS2 mRNA levels at various time points following degrader treatment. An increase in transcript levels is a clear sign of a transcriptional feedback loop. [\[5\]](#)[\[17\]](#)
 - Phosphoproteomics: Use mass spectrometry to analyze changes in protein phosphorylation. This can reveal the activation of bypass signaling pathways that may contribute to resistance. [\[5\]](#)
 - Combination Therapy: The emergence of resistance mechanisms is a strong rationale for combination therapies. SOS1 degraders have shown synergistic effects when combined with KRAS or MEK inhibitors. [\[6\]](#)[\[7\]](#)[\[10\]](#)

Section 3: Key Experimental Protocols

Here we provide streamlined, step-by-step methodologies for core experiments in an SOS1 degrader project.

Protocol 1: Quantitative Western Blot for SOS1 Degradation

This is the foundational assay to determine the concentration- and time-dependence of degradation.

- Cell Culture & Treatment:
 - Plate cells (e.g., KRAS-mutant NCI-H358 or MIA PaCa-2) at a consistent density and allow them to adhere overnight.[\[5\]](#)[\[6\]](#)
 - Prepare serial dilutions of your SOS1 degrader in culture medium. A typical concentration range to test for a new compound is 1 nM to 10 μ M.
 - Treat cells for a specified time course (e.g., 2, 4, 8, 24 hours). Include a vehicle control (e.g., 0.1% DMSO).[\[15\]](#)
- Cell Lysis:
 - Wash cells twice with ice-cold PBS.
 - Lyse cells in RIPA buffer supplemented with protease and phosphatase inhibitors.
 - Determine protein concentration using a BCA assay.
- Western Blotting:
 - Load equal amounts of protein (e.g., 20-30 μ g) per lane on an SDS-PAGE gel.
 - Transfer proteins to a PVDF membrane.
 - Block the membrane (e.g., 5% non-fat milk or BSA in TBST) for 1 hour at room temperature.
 - Incubate with a primary antibody against SOS1 overnight at 4°C.
 - Incubate with a primary antibody against a loading control (e.g., GAPDH, β -actin) to ensure equal loading.

- Wash and incubate with the appropriate HRP-conjugated secondary antibody for 1 hour at room temperature.
- Develop with an ECL substrate and image the blot.
- Quantification:
 - Use densitometry software (e.g., ImageJ) to quantify the band intensity for SOS1 and the loading control.
 - Normalize the SOS1 signal to the loading control for each lane.
 - Calculate the percentage of remaining SOS1 relative to the vehicle-treated control.
 - Use software like GraphPad Prism to plot the dose-response curve and calculate DC₅₀ (concentration for 50% degradation) and Dmax (maximal degradation).[5]

Published SOS1 Degradation Examples	E3 Ligase	Cell Line	DC ₅₀ (24h)	Dmax (24h)	Reference
P7	CRBN	SW620	0.59 μM	87%	[5]
9d (Agonist-based)	VHL	NCI-H358	98.4 nM	>90%	[13]
SIAIS562055	CRBN	MIA PaCa-2	<10 nM	>90%	[4][7]
BTX-6654	CRBN	MIA PaCa-2	<10 nM	>90%	[6]

Protocol 2: Confirming Mechanism of Degradation

This set of experiments is crucial to validate that your compound works through the intended ubiquitin-proteasome pathway.

- Experimental Setup: Use the optimal degrader concentration and time point determined in Protocol 1.

- Proteasome Inhibition:
 - Pre-treat cells with a proteasome inhibitor (e.g., 10 μ M MG132) or a neddylation inhibitor (e.g., 0.5 μ M MLN4924) for 1-2 hours.[3][5]
 - Add your SOS1 degrader (co-treatment) and incubate for the desired duration.
 - Harvest lysates and perform a Western blot for SOS1.
 - Expected Outcome: Pre-treatment with MG132 or MLN4924 should "rescue" SOS1 from degradation, meaning SOS1 levels will be similar to the vehicle control. This confirms degradation is proteasome-dependent.[5][10]
- E3 Ligase Competition:
 - Pre-treat cells with an excess of a competitor ligand for the E3 ligase you are targeting. For a CRBN-based degrader, use a high concentration of lenalidomide (e.g., 10 μ M).[4][5]
 - Add your SOS1 degrader and incubate.
 - Harvest lysates and perform a Western blot for SOS1.
 - Expected Outcome: The competitor ligand will occupy the E3 ligase, preventing the degrader from binding. This should block SOS1 degradation.[4][5] This confirms the involvement of the specific E3 ligase.

References

- Guan, X., et al. (2022). Development of SOS1 inhibitor-based degraders to target KRAS-mutant colorectal cancer. *Journal of Medicinal Chemistry*. Available at: [\[Link\]](#)
- Biotheryx. (n.d.). Cereblon-based Bifunctional Degradator of SOS1, BTX-6654, Targets Multiple KRAS Mutations and Inhibits Tumor Growth. Biotheryx. Available at: [\[Link\]](#)
- Gluetacs. (2024). Gluetacs jointly reported the mechanism of SOS1 degrader overcoming KRAS mutation and BCR-ABL-positive CML resistance in *Cancer Research*. Gluetacs. Available at: [\[Link\]](#)

- Kim, J., et al. (2025). Development of a potent SOS1 degrader exhibiting superior combination effects with anti-cancer drugs in various tumor models. AACR Journals. Available at: [\[Link\]](#)
- ACS Publications. (2022). Development of SOS1 Inhibitor-Based Degraders to Target KRAS-Mutant Colorectal Cancer. Journal of Medicinal Chemistry. Available at: [\[Link\]](#)
- Hallin, J., et al. (2021). The SOS1 Inhibitor MRTX0902 Blocks KRAS Activation and Demonstrates Antitumor Activity in Cancers Dependent on KRAS Nucleotide Loading. Cancer Research. Available at: [\[Link\]](#)
- Jiang, B., et al. (2025). Targeted Degradation of SOS1 Exhibits Potent Anticancer Activity and Overcomes Resistance in KRAS-Mutant Tumors and BCR–ABL–Positive Leukemia. Cancer Research. Available at: [\[Link\]](#)
- FirstWord Pharma. (2023). Biotheryx Presents Preclinical CDK4/6 and SOS1 Protein Degradation Data at AACR 2023 Annual Meeting. FirstWord Pharma. Available at: [\[Link\]](#)
- Bentham Science. (2023). Targeting of SOS1: from SOS1 Activators to Proteolysis Targeting Chimeras. Current Pharmaceutical Design. Available at: [\[Link\]](#)
- AACR Journals. (2025). Targeted Degradation of SOS1 Exhibits Potent Anticancer Activity and Overcomes Resistance in KRAS-Mutant Tumors and BCR–ABL–Positive Leukemia. Cancer Research. Available at: [\[Link\]](#)
- Tech Science Press. (2024). Development of PROTACS degrading KRAS and SOS1. Oncology Research. Available at: [\[Link\]](#)
- ResearchGate. (2024). Development of PROTACS degrading KRAS and SOS1. ResearchGate. Available at: [\[Link\]](#)
- MDPI. (2021). Small-Molecule Inhibitors and Degraders Targeting KRAS-Driven Cancers. International Journal of Molecular Sciences. Available at: [\[Link\]](#)
- Zhu, C., et al. (2022). Discovery of the First-in-Class Agonist-Based SOS1 PROTACS Effective in Human Cancer Cells Harboring Various KRAS Mutations. Journal of Medicinal Chemistry. Available at: [\[Link\]](#)

- AACR Journals. (2023). Abstract B002: Development of bifunctional CRBN-SOS1 degraders for treatment of mutant KRAS cancers. *Molecular Cancer Therapeutics*. Available at: [\[Link\]](#)
- Chen, K., et al. (2022). Translational relevance of SOS1 targeting for KRAS-mutant colorectal cancer. *Journal of Experimental & Clinical Cancer Research*. Available at: [\[Link\]](#)
- DOKUMEN.PUB. (n.d.). Targeted Protein Degradation: Methods and Protocols. DOKUMEN.PUB. Available at: [\[Link\]](#)
- Technology Networks. (2026). Assays and Strategies for Targeted Protein Degradation Development. *Technology Networks*. Available at: [\[Link\]](#)
- Biocompare. (2022). PROTACs: A Practical Guide. *Biocompare*. Available at: [\[Link\]](#)
- ACS Publications. (2021). One Atom Makes All the Difference: Getting a Foot in the Door between SOS1 and KRAS. *Journal of Medicinal Chemistry*. Available at: [\[Link\]](#)
- ACS Publications. (2022). Development of SOS1 Inhibitor-Based Degraders to Target KRAS-Mutant Colorectal Cancer. *Journal of Medicinal Chemistry*. Available at: [\[Link\]](#)
- ResearchGate. (2022). Development of SOS1 Inhibitor-Based Degraders to Target KRAS-Mutant Colorectal Cancer. *ResearchGate*. Available at: [\[Link\]](#)
- Ci, C., et al. (2020). Assays and technologies for developing proteolysis targeting chimera degraders. *Future Medicinal Chemistry*. Available at: [\[Link\]](#)
- Cuesta-Calvo, F., et al. (2023). SOS1 inhibitor BI-3406 shows in vivo antitumor activity akin to genetic ablation and synergizes with a KRASG12D inhibitor in KRAS LUAD. *PNAS*. Available at: [\[Link\]](#)
- ACS Publications. (2023). Targeted Protein Degradation: Advances, Challenges, and Prospects for Computational Methods. *Journal of Chemical Information and Modeling*. Available at: [\[Link\]](#)
- Biotheryx. (n.d.). Biotheryx to Present New Preclinical Data on Bifunctional Degraders for CDK4/6 and SOS1 at 2023 ASCO Annual Meeting. *Biotheryx*. Available at: [\[Link\]](#)

- Tran, N.L., et al. (2023). Targeted Protein Degradation: Design Considerations for PROTAC Development. STAR Protocols. Available at: [[Link](#)]
- eScholarship. (2022). Targeted Protein Degradation: Design Considerations for PROTAC Development. eScholarship. Available at: [[Link](#)]

Need Custom Synthesis?

BenchChem offers custom synthesis for rare earth carbides and specific isotopic labeling.

Email: info@benchchem.com or [Request Quote Online](#).

Sources

- 1. revvity.com [revvity.com]
- 2. OR | Free Full-Text | Development of PROTACS degrading KRAS and SOS1 [techscience.com]
- 3. aacrjournals.org [aacrjournals.org]
- 4. aacrjournals.org [aacrjournals.org]
- 5. Development of SOS1 inhibitor-based degraders to target KRAS-mutant colorectal cancer - PMC [pmc.ncbi.nlm.nih.gov]
- 6. biotheryx.com [biotheryx.com]
- 7. gluetacs.com [gluetacs.com]
- 8. pubs.acs.org [pubs.acs.org]
- 9. pdf.benchchem.com [pdf.benchchem.com]
- 10. aacrjournals.org [aacrjournals.org]
- 11. Targeted Degradation of SOS1 Exhibits Potent Anticancer Activity and Overcomes Resistance in KRAS-Mutant Tumors and BCR–ABL–Positive Leukemia - PMC [pmc.ncbi.nlm.nih.gov]
- 12. dokumen.pub [dokumen.pub]
- 13. pubs.acs.org [pubs.acs.org]
- 14. Targeted Protein Degradation: Design Considerations for PROTAC Development - PMC [pmc.ncbi.nlm.nih.gov]

- [15. pdf.benchchem.com \[pdf.benchchem.com\]](https://pdf.benchchem.com)
- [16. escholarship.org \[escholarship.org\]](https://escholarship.org)
- [17. pubs.acs.org \[pubs.acs.org\]](https://pubs.acs.org)
- To cite this document: BenchChem. [SOS1 Degradation Development: A Technical Support Guide]. BenchChem, [2026]. [Online PDF]. Available at: [\[https://www.benchchem.com/product/b12419217/docs#sos1-degrader-development-a-technical-support-guide\]](https://www.benchchem.com/product/b12419217/docs#sos1-degrader-development-a-technical-support-guide)

Disclaimer & Data Validity:

The information provided in this document is for Research Use Only (RUO) and is strictly not intended for diagnostic or therapeutic procedures. While BenchChem strives to provide accurate protocols, we make no warranties, express or implied, regarding the fitness of this product for every specific experimental setup.

Technical Support: The protocols provided are for reference purposes. Unsure if this reagent suits your experiment?

Need Industrial/Bulk Grade? [Request Custom Synthesis Quote](#)

BenchChem

Our mission is to be the trusted global source of essential and advanced chemicals, empowering scientists and researchers to drive progress in science and industry.

Contact

Address: 3281 E Guasti Rd
Ontario, CA 91761, United States
Phone: (601) 213-4426
Email: info@benchchem.com

[Contact our Ph.D. Support Team for a compatibility check](#)

