

# Application Notes: NF110 Dosage and Administration for Cell Culture Experiments

**Author:** BenchChem Technical Support Team. **Date:** April 2026

## Compound of Interest

Compound Name: NF110  
Cat. No.: B12419100

[Get Quote](#)

## Introduction

**NF110** is a potent and selective antagonist of the P2X3 receptor, a ligand-gated ion channel activated by extracellular adenosine triphosphate (ATP).[1][2] It is a suramin analogue, characterized by its polysulfonated structure, which contributes to its high affinity for the P2X3 receptor subtype.[3] Due to its role in blocking ATP-mediated signaling, **NF110** is a valuable tool for investigating the function of P2X3 receptors in various physiological and pathological processes, including pain, inflammation, and cancer.[3] These notes provide detailed protocols and guidelines for the effective use of **NF110** in in vitro cell culture experiments.

## Mechanism of Action

**NF110** exerts its primary effect by competitively binding to P2X3 receptors, thereby preventing the binding of the endogenous agonist, ATP. P2X3 receptors are ion channels that, upon activation, allow the influx of cations such as Na<sup>+</sup> and Ca<sup>2+</sup>, leading to membrane depolarization and initiation of downstream cellular responses. By blocking this initial step, **NF110** effectively inhibits the entire signaling cascade. While its primary target is the P2X3 receptor, it also shows some activity against P2X1 receptors at higher concentrations. It is largely inactive toward P2Y receptors.[1][2][4] Additionally, **NF110** has been reported to inhibit

the DNA-binding activity of High Mobility Group A2 (HMGA2), suggesting alternative mechanisms of action in specific contexts like cancer.

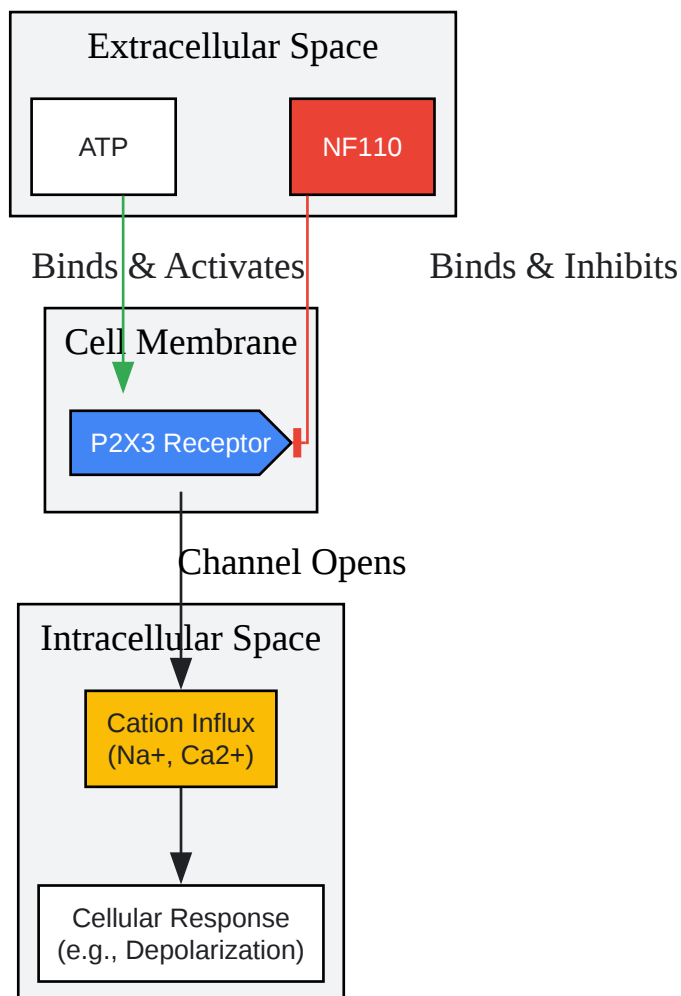

[Click to download full resolution via product page](#)

**Caption: NF110** mechanism as a P2X3 receptor antagonist.

## Quantitative Data Summary

The following table summarizes the key quantitative parameters of **NF110** activity derived from various experimental systems. These values are crucial for determining appropriate starting concentrations for in vitro studies. Note that IC<sub>50</sub> values can vary based on experimental conditions, including agonist concentration and cell type used.[5][6]

Parameter	Species/System	Value	Reference
Ki (Inhibition Constant)	Recombinant P2X <sub>3</sub> Receptor	36 nM	[1][2]
Recombinant P2X <sub>1</sub> Receptor	82 nM		
Recombinant P2X <sub>2</sub> Receptor	4144 nM		
IC <sub>50</sub> (Half Maximal Inhibitory Concentration)	α,β-meATP-induced currents (Rat DRG Neurons)	527 nM	[1][2]
Human Tumour Cell Line Panel (IC <sub>30</sub> )	362.3 μM	[1]	
HMGA2-DNA Interaction Inhibition	0.87 μM	[1]	
Solubility	Water	Up to 40 mg/mL	

## Experimental Protocols

### Reagent Preparation and Storage

Proper preparation and storage of **NF110** are critical for maintaining its activity and ensuring experimental reproducibility.

- **Reconstitution:** **NF110** is soluble in water up to 40 mg/mL. For cell culture experiments, it is recommended to prepare a high-concentration stock solution (e.g., 10-40 mM) in sterile, nuclease-free water or a suitable buffer like PBS. Vortex gently to ensure complete dissolution.
- **Stock Solution Storage:** Aliquot the stock solution into smaller volumes to avoid repeated freeze-thaw cycles. Store aliquots at -20°C for up to two years or as recommended by the supplier.[2][4]

- **Working Solution Preparation:** On the day of the experiment, thaw an aliquot of the stock solution. Prepare fresh dilutions to the desired final concentrations using the appropriate cell culture medium. It is crucial to ensure that the final concentration of any solvent (if used) is minimal and does not affect cell viability. A vehicle control should always be included in the experimental design.

## General Protocol for Cell Treatment

This protocol provides a general workflow for treating adherent cells with **NF110**. The specific concentrations and incubation times should be optimized for each cell type and experimental endpoint.

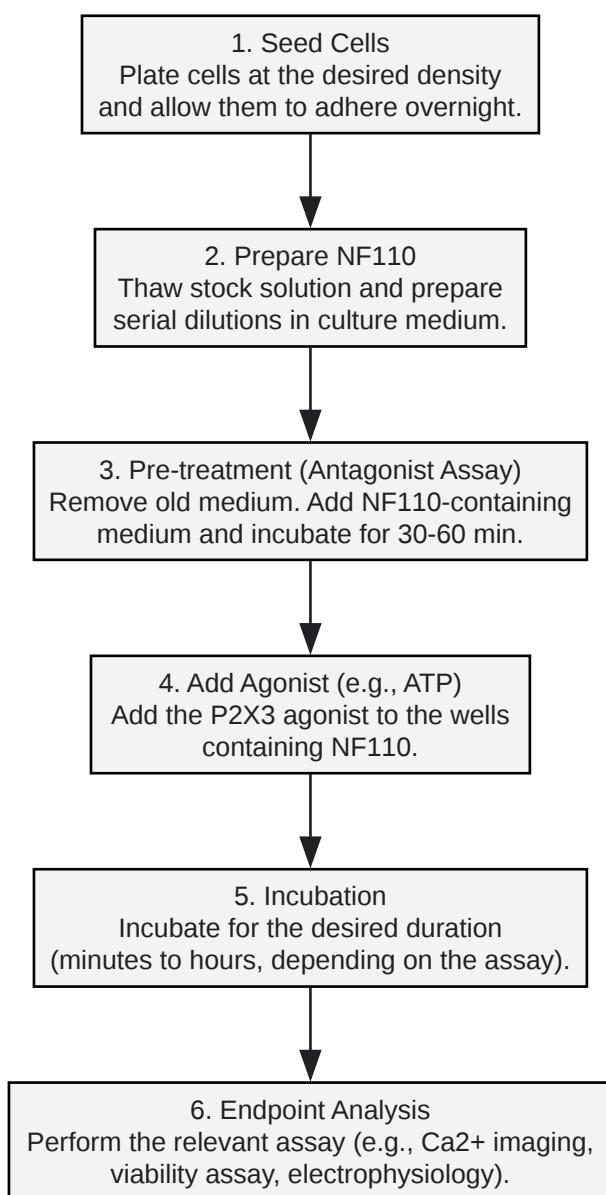

[Click to download full resolution via product page](#)

**Caption:** General experimental workflow for an **NF110** cell culture assay.

Methodology:

- **Cell Seeding:** Plate cells in a suitable format (e.g., 96-well plate) at a density that ensures they are in the logarithmic growth phase at the time of treatment. Allow cells to adhere and recover for 18-24 hours in a humidified incubator at 37°C and 5% CO<sub>2</sub>.
- **Preparation of Treatment Media:** Prepare serial dilutions of **NF110** in fresh, pre-warmed culture medium to achieve the desired final concentrations. Also, prepare a vehicle control (medium only) and an agonist control (if applicable).
- **NF110 Pre-incubation:** Gently aspirate the culture medium from the wells. Add the prepared **NF110** treatment media to the respective wells. For antagonism studies, a pre-incubation period of 30-60 minutes is often sufficient to allow the compound to bind to the receptors.
- **Agonist Stimulation:** If studying the inhibitory effect of **NF110**, add the P2X3 agonist (e.g., ATP or  $\alpha,\beta$ -methylene-ATP) to the wells. The final concentration of the agonist should ideally be around its EC<sub>50</sub> or EC<sub>80</sub> for the specific cell type to create a suitable window for observing inhibition.
- **Incubation:** Return the plate to the incubator for the required duration. This can range from minutes for acute signaling events (like calcium influx) to 24-72 hours for proliferation or cytotoxicity assays.
- **Endpoint Analysis:** Following incubation, perform the desired analysis. This could include measuring changes in intracellular calcium, assessing cell viability (e.g., MTT or CellTiter-Glo® assays), or performing electrophysiological recordings to measure ion channel activity.

[1]

## Example Protocol: Inhibition of ATP-Induced Calcium Influx

This protocol is designed to assess the potency of **NF110** in blocking P2X3 receptor-mediated calcium signaling.

- Cell Line: A cell line endogenously expressing P2X3 receptors (e.g., dorsal root ganglia neurons, certain neuroblastoma or cancer cell lines) or a recombinant cell line overexpressing P2X3.
- Materials:
  - Cells seeded in a black, clear-bottom 96-well plate.
  - Calcium-sensitive fluorescent dye (e.g., Fluo-4 AM).
  - **NF110** stock solution.
  - P2X3 agonist stock solution (e.g.,  $\alpha,\beta$ -methylene-ATP).
  - Assay Buffer (e.g., Hanks' Balanced Salt Solution with  $\text{Ca}^{2+}$  and  $\text{Mg}^{2+}$ ).
  - Fluorescence plate reader with an injection system.

#### Methodology:

- Cell Plating: Seed cells at an appropriate density to form a confluent monolayer on the day of the assay.
- Dye Loading: Aspirate the culture medium and wash the cells once with Assay Buffer. Add the calcium indicator dye solution (e.g., Fluo-4 AM in Assay Buffer) to each well and incubate for 30-60 minutes at 37°C, protected from light.
- Wash and Pre-incubation: Remove the dye solution, wash the cells gently twice with Assay Buffer. Add Assay Buffer containing the desired concentrations of **NF110** (and vehicle control) to the wells. Incubate for 20-30 minutes at room temperature.
- Fluorescence Measurement: Place the plate in a fluorescence plate reader. Set the instrument to record fluorescence intensity over time (e.g., excitation at 485 nm, emission at 525 nm).
- Agonist Injection and Data Acquisition: Begin recording a baseline fluorescence reading. After a few seconds, use the plate reader's injector to add the P2X3 agonist to all wells

simultaneously. Continue recording the fluorescence signal for 1-3 minutes to capture the peak calcium response.

- Data Analysis: Calculate the change in fluorescence (peak signal minus baseline) for each well. Plot the response against the concentration of **NF110** and fit the data to a four-parameter logistic equation to determine the IC<sub>50</sub> value.

### Need Custom Synthesis?

BenchChem offers custom synthesis for rare earth carbides and specific isotopic labeling.

Email: [info@benchchem.com](mailto:info@benchchem.com) or [Request Quote Online](#).

## References

- [1. medchemexpress.com \[medchemexpress.com\]](https://www.medchemexpress.com)
- [2. NF110 Datasheet DC Chemicals \[dcchemicals.com\]](https://www.dcchemicals.com)
- [3. P2X3 Receptor Ligands: Structural Features and Potential Therapeutic Applications - PMC \[pmc.ncbi.nlm.nih.gov\]](https://pubmed.ncbi.nlm.nih.gov/11115022/)
- [4. NF110\[111150-22-2\]COA \[dcchemicals.com\]](https://www.dcchemicals.com)
- [5. IC50 - Wikipedia \[en.wikipedia.org\]](https://en.wikipedia.org)
- [6. researchgate.net \[researchgate.net\]](https://www.researchgate.net)
- To cite this document: BenchChem. [Application Notes: NF110 Dosage and Administration for Cell Culture Experiments]. BenchChem, [2026]. [Online PDF]. Available at: [\[https://www.benchchem.com/product/b12419100/docs#application-notes-nf110-dosage-and-administration-for-cell-culture-experiments\]](https://www.benchchem.com/product/b12419100/docs#application-notes-nf110-dosage-and-administration-for-cell-culture-experiments)

---

### Disclaimer & Data Validity:

The information provided in this document is for Research Use Only (RUO) and is strictly not intended for diagnostic or therapeutic procedures. While BenchChem strives to provide accurate protocols, we make no warranties, express or implied, regarding the fitness of this product for every specific experimental setup.

**Technical Support:** The protocols provided are for reference purposes. Unsure if this reagent suits your experiment?

**Need Industrial/Bulk Grade?** [Request Custom Synthesis Quote](#)

## BenchChem

Our mission is to be the trusted global source of essential and advanced chemicals, empowering scientists and researchers to drive progress in science and industry.

### Contact

Address: 3281 E Guasti Rd  
Ontario, CA 91761, United States  
Phone: (601) 213-4426  
Email: [info@benchchem.com](mailto:info@benchchem.com)

[Contact our Ph.D. Support Team for a compatibility check](#)