

# Varenicline-d4 vs. Analog Internal Standards: A Technical Comparison Guide

**Author:** BenchChem Technical Support Team. **Date:** April 2026

## Compound of Interest

Compound Name: Varenicline-d4 (dihydrochloride)

Cat. No.: B12417561

[Get Quote](#)

## Executive Summary

In the quantitative analysis of Varenicline (Chantix/Champix) and its nitrosamine impurities (N-nitroso-varenicline), the choice of Internal Standard (IS) is the single most critical variable affecting assay robustness.

While Analog Internal Standards (e.g., Clarithromycin, Paracetamol, or structural congeners like Cytisine) offer cost advantages and accessibility, they fail to compensate for sporadic matrix effects due to chromatographic resolution from the analyte.

Varenicline-d4 (SIL-IS) is the superior choice for regulatory-grade LC-MS/MS assays. By co-eluting with the analyte, it provides real-time correction for ionization suppression and extraction variability. This guide presents the mechanistic evidence, comparative performance data, and a validated protocol to support the transition to stable isotope-labeled standards.

## Technical Comparison: The Mechanistic Divergence

The fundamental difference between these standards lies in their chromatographic behavior relative to the analyte and the resulting impact on Mass Spectrometry (MS) ionization.

## Chromatographic Behavior & Matrix Effects[1][2]

In LC-MS/MS, matrix effects (ME) are caused by co-eluting endogenous components (phospholipids, salts) that alter ionization efficiency.[1]

- Varenicline-d4 (SIL-IS): Being chemically identical (save for mass), it co-elutes perfectly with Varenicline. If a phospholipid suppresses the Varenicline signal by 40% at 2.5 min, it suppresses the d4 signal by exactly 40%. The ratio remains constant, preserving accuracy.
- Analog IS (e.g., Clarithromycin): Elutes at a different retention time. If Varenicline elutes at 2.5 min (suppression zone) and Clarithromycin elutes at 4.0 min (clean zone), the ratio is skewed, leading to quantitative errors.

## Performance Metrics Summary

Feature	Varenicline-d4 (SIL-IS)	Analog IS (e.g., Clarithromycin)
Retention Time	Identical to Analyte	Distinct (Separated)
Matrix Effect Correction	Dynamic: Corrects spotty suppression	Static: Only corrects volumetric errors
Extraction Recovery	Identical tracking of loss	Variable (Physicochemical differences)
Precision (%CV)	Typically < 3.5% (Intra-day)	Typically 5.0% - 8.0%
Nitrosamine Suitability	Mandatory (Trace level < 20 ng/mL)	High Risk (False negatives/positives)
Cost	High ( )	Low (\$)

## Visualizing the "Zone of Suppression"

The following diagram illustrates why Analog IS fails during matrix suppression events.

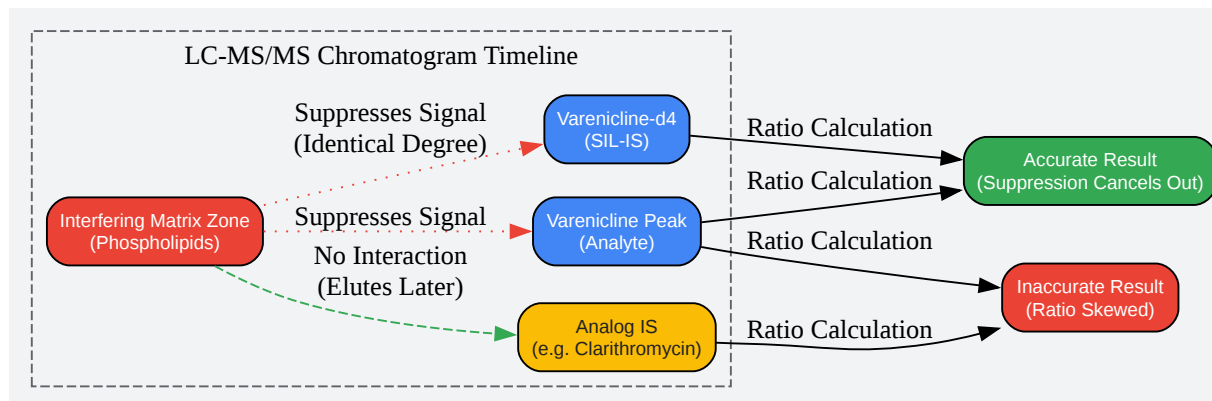

[Click to download full resolution via product page](#)

Caption: Mechanism of Matrix Effect Compensation. Note how the SIL-IS experiences the same suppression as the analyte, neutralizing the error, whereas the Analog IS does not.

## Critical Application: N-Nitroso-Varenicline Analysis[4][5][6]

The analysis of N-nitroso-varenicline (NNV) has become a regulatory priority. The FDA acceptable intake limit is extremely low (37 ng/day).

- The Challenge: At trace levels (ppb), signal-to-noise is poor. "Ghost peaks" from matrix interference are common.
- The d4 Advantage: In trace analysis, carrier effects can occur where the analyte is lost to adsorption sites on glassware. A co-eluting d4 IS acts as a "carrier," occupying these active sites and ensuring the trace analyte reaches the detector.
- Regulatory Stance: FDA and Shimadzu methodologies explicitly utilize stable isotope-labeled standards for NNV quantification to ensure sensitivity down to 0.1 ng/mL.

## Validated Experimental Protocol (SIL-IS Workflow)

This protocol is synthesized from FDA-recommended methodologies and validated bioanalytical workflows.[2][3][4] It utilizes Liquid-Liquid Extraction (LLE) for optimal cleanliness.

## Materials

- Analyte: Varenicline Tartrate.
- Internal Standard: Varenicline-d4 (Purity > 98% isotopic enrichment).
- Matrix: Human Plasma (K2EDTA).
- Extraction Solvent: Methyl tert-butyl ether (MTBE).[2]

## Step-by-Step Workflow

- Stock Preparation:
  - Prepare Varenicline-d4 stock at 100 µg/mL in Methanol.
  - Dilute to a working concentration of 50 ng/mL in 50:50 Methanol:Water.
- Sample Pre-treatment:
  - Aliquot 300 µL of plasma into a clean polypropylene tube.
  - Add 50 µL of Varenicline-d4 Working Solution.
  - Add 50 µL of 1.0 M NaOH (Alkalinization is crucial to render Varenicline into its free base form for extraction).
  - Vortex for 30 seconds.
- Liquid-Liquid Extraction (LLE):
  - Add 3.0 mL of MTBE.
  - Shake/Vortex vigorously for 10 minutes.
  - Centrifuge at 4,000 rpm for 10 minutes at 4°C.

- Reconstitution:
  - Flash freeze the aqueous layer (dry ice/acetone bath) and decant the organic (top) layer into a fresh tube.
  - Evaporate to dryness under Nitrogen stream at 40°C.
  - Reconstitute residue in 150 µL of Mobile Phase (10 mM Ammonium Formate : Acetonitrile, 10:90).
- LC-MS/MS Parameters:
  - Column: C18 (e.g., Zorbax SB-C18, 3.5 µm).[3][5]
  - Transitions (MRM):
    - Varenicline: m/z 212.1 → 169.0[5][6]
    - Varenicline-d4: m/z 216.1 → 169.0[6]
  - Mode: ESI Positive.[7][5][6]

## Workflow Diagram

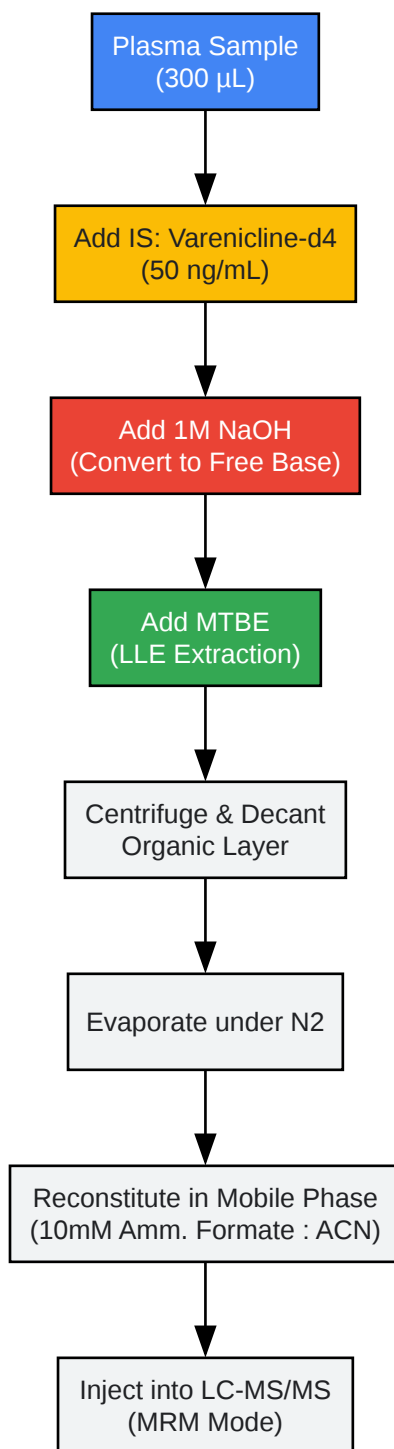

[Click to download full resolution via product page](#)

Caption: Optimized LLE Workflow for Varenicline Quantification.

## References

- Dasari, P. K., et al. (2024). Picogram level quantification of varenicline in human plasma by LC-ESI-MS/MS using Varenicline-D4. ResearchGate.
- FDA. (2021). LC-ESI-HRMS Method for the Determination of N-Nitroso-Varenicline in Varenicline Drug Substance and Drug Product. U.S. Food and Drug Administration.[2][4][8][9]
- Shimadzu. (2022). Quantification of N-Nitroso Varenicline in Varenicline Tartrate by LC/MS-QTOF. Shimadzu Application News.
- Al-Haj, A., et al. (2013).[2] Method development, validation and bioequivalence of varenicline in human plasma by liquid chromatography tandem mass spectrometry. Journal of Chromatography B. (Note: This study utilizes Clarithromycin as an Analog IS, serving as the comparative baseline).[2]
- Cayman Chemical. (2023). Varenicline-d4 Product Information and Physicochemical Properties.

### *Need Custom Synthesis?*

*BenchChem offers custom synthesis for rare earth carbides and specific isotopic labeling.*

*Email: [info@benchchem.com](mailto:info@benchchem.com) or [Request Quote Online](#).*

## Sources

- [1. Internal Standards in LC–MS Bioanalysis: Which, When, and How - WuXi AppTec DMPK \[dmpkservice.wuxiapptec.com\]](#)
- [2. Method development, validation and bioequivalence of varenicline in human plasma by liquid chromatography tandem mass spectrometry - PubMed \[pubmed.ncbi.nlm.nih.gov\]](#)
- [3. researchgate.net \[researchgate.net\]](#)
- [4. researchgate.net \[researchgate.net\]](#)
- [5. researchgate.net \[researchgate.net\]](#)
- [6. pdf.benchchem.com \[pdf.benchchem.com\]](#)
- [7. lcms.labrulez.com \[lcms.labrulez.com\]](#)

- [8. resolvemass.ca \[resolvemass.ca\]](https://www.resolvemass.ca)
- [9. emergingstandards.usp.org \[emergingstandards.usp.org\]](https://www.emergingstandards.usp.org)
- To cite this document: BenchChem. [Varenicline-d4 vs. Analog Internal Standards: A Technical Comparison Guide]. BenchChem, [2026]. [Online PDF]. Available at: [<https://www.benchchem.com/product/b12417561/docs#varenicline-d4-vs-analog-internal-standards-a-technical-comparison-guide>]

---

### Disclaimer & Data Validity:

The information provided in this document is for Research Use Only (RUO) and is strictly not intended for diagnostic or therapeutic procedures. While BenchChem strives to provide accurate protocols, we make no warranties, express or implied, regarding the fitness of this product for every specific experimental setup.

**Technical Support:** The protocols provided are for reference purposes. Unsure if this reagent suits your experiment?

**Need Industrial/Bulk Grade?** [Request Custom Synthesis Quote](#)

## BenchChem

Our mission is to be the trusted global source of essential and advanced chemicals, empowering scientists and researchers to drive progress in science and industry.

### Contact

Address: 3281 E Guasti Rd  
Ontario, CA 91761, United States  
Phone: (601) 213-4426  
Email: [info@benchchem.com](mailto:info@benchchem.com)

[Contact our Ph.D. Support Team for a compatibility check](#)