

Independent Verification of SARS-CoV-2 nsp16 Inhibitors: A Comparative Guide

Author: BenchChem Technical Support Team. **Date:** December 2025

Compound of Interest

Compound Name: SARS-CoV-2-IN-16

Cat. No.: B12417908

[Get Quote](#)

For Researchers, Scientists, and Drug Development Professionals

This guide provides an objective comparison of published data on inhibitors targeting the SARS-CoV-2 non-structural protein 16 (nsp16), a critical enzyme for viral replication and immune evasion. By summarizing quantitative data, detailing experimental protocols, and visualizing key pathways, this document aims to facilitate the independent verification and advancement of potential therapeutic agents against COVID-19.

Mechanism of Action of SARS-CoV-2 nsp16

SARS-CoV-2 nsp16 is a 2'-O-methyltransferase that plays a crucial role in the virus's ability to evade the host's innate immune system.^{[1][2]} Its primary function is to add a methyl group to the 5' cap of viral messenger RNA (mRNA). This process, known as cap-1 formation, makes the viral mRNA mimic host mRNA, preventing its recognition by cellular pattern recognition receptors like RIG-I and IFIT, which would otherwise trigger an antiviral interferon response.^[2]

For nsp16 to be active, it must form a stable heterodimeric complex with another non-structural protein, nsp10.^{[1][2][3]} Nsp10 acts as a crucial cofactor, stabilizing nsp16 and enhancing its binding affinity for both the methyl donor, S-adenosylmethionine (SAM), and the viral RNA substrate.^{[2][4][5]} The inhibition of nsp16's methyltransferase activity is a promising antiviral strategy, as it would expose the viral RNA to the host's immune defenses, leading to viral attenuation.^{[1][2]}

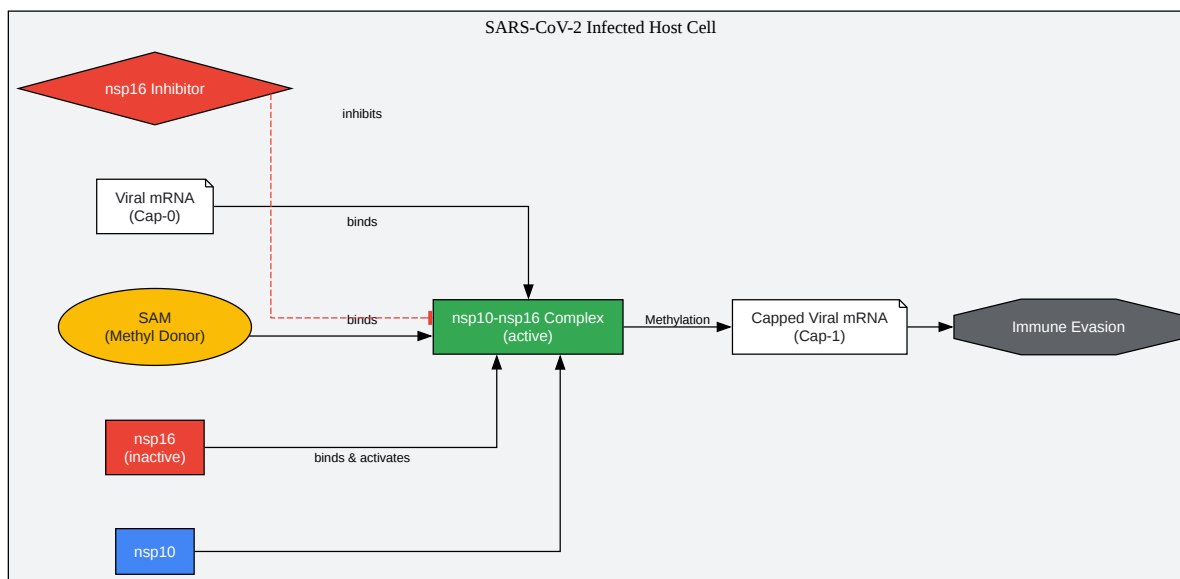

[Click to download full resolution via product page](#)

Figure 1: SARS-CoV-2 nsp16 activation and RNA capping pathway.

Quantitative Data on nsp16 Inhibitors

The following table summarizes the quantitative data for various compounds that have been reported to inhibit SARS-CoV-2 nsp16. The data is compiled from multiple peer-reviewed publications and includes metrics such as IC50 (half-maximal inhibitory concentration), Kd (dissociation constant), and pKi (the negative logarithm of the inhibition constant).

Compound	Assay Type	IC50 (μM)	Kd (μM)	pKi (nM)	Reference
Natural Products & Derivatives					
ZINC128808 20	Microscale Thermophoresis	>10	29.08 ± 2.86	-	[4][6]
ZINC212101 2	Microscale Thermophoresis	>10	23.14 ± 1.05	-	[4][6]
ZINC212902 8	Microscale Thermophoresis	>10	59.95 ± 2.53	-	[4][6]
Genkwanin-6-C-beta-glucopyranoside	In vivo (predicted)	0.029 - 0.035	-	-	[7]
Synthetic Compounds					
SS148	Radioactivity-based Assay	1.2 ± 0.4	-	-	[8][9]
WZ16	Radioactivity-based Assay	3.4 ± 0.7	-	-	[8][9]
S-adenosylhomocysteine (SAH)	Radioactivity-based Assay	2.2 ± 0.2	-	-	[9]
ZINC Database Compounds (Predicted)					

ZINC215510 0	In silico (AutoDock)	-	-	0.002 ± 0.00	[4] [6] [10]
ZINC823672 1	In silico (AutoDock)	-	-	0.56 ± 0.08	[4] [6] [10]
ZINC211963 5	In silico (AutoDock)	-	-	0.85 ± 0.00	[4] [6] [10]
ZINC212101 2	In silico (AutoDock)	-	-	4.51 ± 0.15	[4] [6] [10]

Experimental Protocols

Accurate and reproducible experimental data are the cornerstone of drug discovery. Below are detailed methodologies for key experiments cited in the study of nsp16 inhibitors.

Microscale Thermophoresis (MST)

MST is a biophysical technique used to quantify biomolecular interactions by measuring the motion of molecules in a microscopic temperature gradient. This motion is sensitive to changes in size, charge, and hydration shell, which are often altered upon ligand binding.

Protocol:

- **Protein Labeling:** The target protein (nsp10-nsp16 complex) is fluorescently labeled. If the protein has a His-tag, a RED-tris-NTA 2nd Generation dye can be used for labeling.
- **Sample Preparation:** A serial dilution of the unlabeled ligand (inhibitor) is prepared in the assay buffer. A constant concentration of the labeled target protein is added to each ligand dilution.
- **Incubation:** The mixtures are incubated to allow the binding reaction to reach equilibrium.
- **Capillary Loading:** The samples are loaded into glass capillaries.
- **MST Measurement:** The capillaries are placed in the MST instrument. An infrared laser creates a precise temperature gradient, and the movement of the fluorescently labeled

protein is monitored.

- **Data Analysis:** The change in thermophoresis is plotted against the ligand concentration, and the data is fitted to a binding model to determine the dissociation constant (Kd).

Homogeneous Time-Resolved Fluorescence (HTRF) Assay

HTRF combines Fluorescence Resonance Energy Transfer (FRET) with time-resolved detection, providing a robust method for measuring enzymatic activity and inhibition in a high-throughput format.

Protocol:

- **Reaction Setup:** The nsp10-nsp16 enzyme complex, the RNA substrate, and the methyl donor (SAM) are combined in a microplate well with the test inhibitor.
- **Enzymatic Reaction:** The reaction is incubated to allow the methylation of the RNA substrate, which produces S-adenosylhomocysteine (SAH) as a byproduct.
- **Detection:** An anti-SAH antibody labeled with a donor fluorophore (e.g., Europium cryptate) and a tracer SAH molecule labeled with an acceptor fluorophore (e.g., d2) are added to the reaction.
- **Signal Measurement:** If no enzymatic reaction has occurred, the antibody binds to the tracer, bringing the donor and acceptor into close proximity and generating a FRET signal. If the enzyme is active, the produced SAH competes with the tracer for antibody binding, leading to a decrease in the FRET signal. The signal is measured after a time delay to reduce background fluorescence.
- **Data Analysis:** The IC50 value of the inhibitor is determined by plotting the HTRF signal against the inhibitor concentration.

Fluorescence Polarization (FP) Based RNA Displacement Assay

This assay measures the displacement of a fluorescently labeled RNA probe from the nsp10-nsp16 complex by a competitive inhibitor.

Protocol:

- **Probe Binding:** A fluorescently labeled RNA substrate is incubated with the nsp10-nsp16 complex. The binding of the large protein complex to the small RNA probe results in a high fluorescence polarization signal.
- **Inhibitor Addition:** Test compounds are added to the wells.
- **Displacement:** If a compound binds to the RNA-binding site on the nsp16 complex, it will displace the fluorescently labeled RNA probe.
- **Signal Measurement:** The displacement of the RNA probe leads to a decrease in the fluorescence polarization signal, as the free probe tumbles more rapidly in solution.
- **Data Analysis:** The change in fluorescence polarization is used to determine the inhibitory activity of the test compounds.

Radioactivity-Based Assay

This is a direct and highly sensitive method to measure the methyltransferase activity of nsp16 by tracking the transfer of a radiolabeled methyl group.

Protocol:

- **Reaction Mixture:** The nsp10-nsp16 complex is incubated with a biotinylated RNA substrate and a radiolabeled methyl donor, [3H]-SAM, in the presence of varying concentrations of the test inhibitor.
- **Enzymatic Reaction:** The reaction is allowed to proceed, during which the [3H]-methyl group is transferred to the RNA substrate.
- **Reaction Quenching:** The reaction is stopped, typically by adding a strong denaturant.
- **Capture and Detection:** The biotinylated RNA product is captured on a streptavidin-coated plate. The incorporated radioactivity is then measured using a scintillation counter.

- **Data Analysis:** The amount of radioactivity is proportional to the enzyme activity. The IC50 value is calculated by plotting the percentage of inhibition against the inhibitor concentration.

Experimental Workflow for nsp16 Inhibitor Screening

The discovery of novel nsp16 inhibitors typically follows a multi-step workflow, starting from a large-scale initial screen and progressing to more detailed characterization of promising candidates.

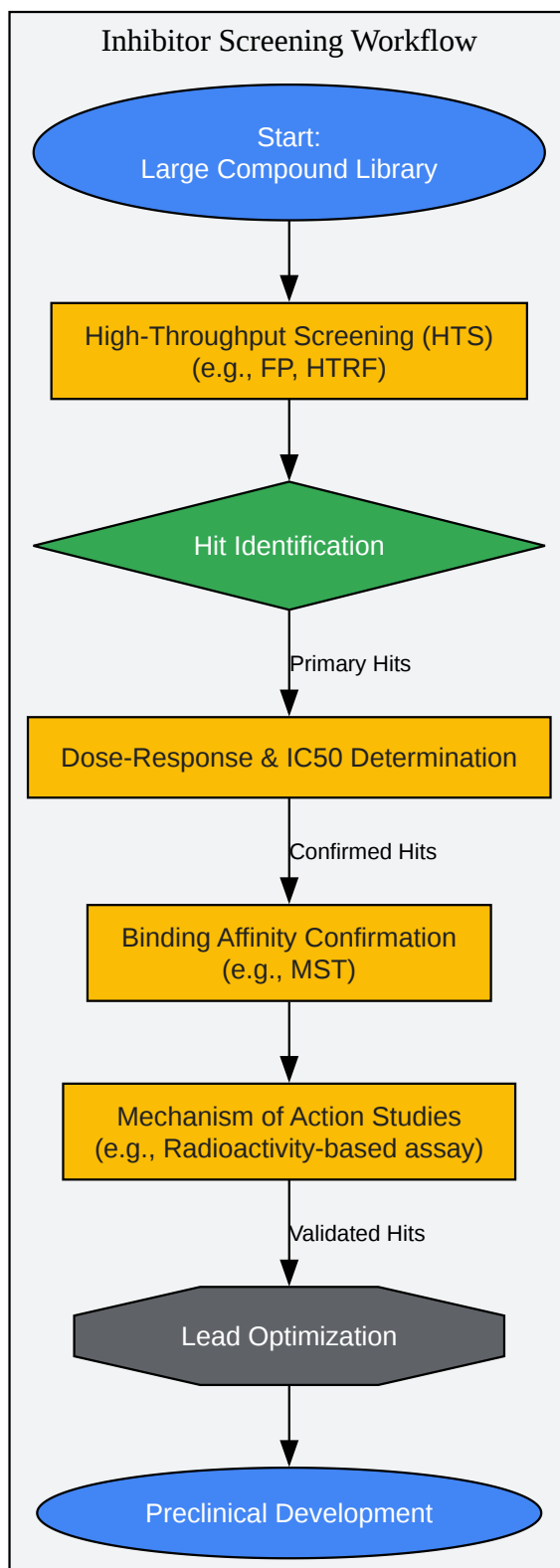

[Click to download full resolution via product page](#)

Figure 2: A generalized workflow for the screening and identification of SARS-CoV-2 nsp16 inhibitors.

Need Custom Synthesis?

BenchChem offers custom synthesis for rare earth carbides and specific isotopic labeling.

Email: info@benchchem.com or [Request Quote Online](#).

References

- 1. SARS-CoV-2 Nsp16 activation mechanism and a cryptic pocket with pan-coronavirus antiviral potential - PMC [[pmc.ncbi.nlm.nih.gov](https://pubmed.ncbi.nlm.nih.gov)]
- 2. Frontiers | Homogeneous Time-Resolved Fluorescence-Based Assay to Monitor Extracellular Signal-Regulated Kinase Signaling in a High-Throughput Format [frontiersin.org]
- 3. Exploring the Catalytic Mechanism of the RNA Cap Modification by nsp16-nsp10 Complex of SARS-CoV-2 through a QM/MM Approach - PMC [[pmc.ncbi.nlm.nih.gov](https://pubmed.ncbi.nlm.nih.gov)]
- 4. [researchgate.net](https://www.researchgate.net) [[researchgate.net](https://www.researchgate.net)]
- 5. Crystal Structure and Functional Analysis of the SARS-Coronavirus RNA Cap 2'-O-Methyltransferase nsp10/nsp16 Complex | PLOS Pathogens [journals.plos.org]
- 6. [researchgate.net](https://www.researchgate.net) [[researchgate.net](https://www.researchgate.net)]
- 7. Molecular Simulation-Based Investigation of Highly Potent Natural Products to Abrogate Formation of the nsp10–nsp16 Complex of SARS-CoV-2 - PMC [[pmc.ncbi.nlm.nih.gov](https://pubmed.ncbi.nlm.nih.gov)]
- 8. Crystal structure of SARS-CoV-2 nsp10–nsp16 in complex with small molecule inhibitors, SS148 and WZ16 - PMC [[pmc.ncbi.nlm.nih.gov](https://pubmed.ncbi.nlm.nih.gov)]
- 9. [researchgate.net](https://www.researchgate.net) [[researchgate.net](https://www.researchgate.net)]
- 10. Coronavirus Inhibitors Targeting nsp16 - PMC [[pmc.ncbi.nlm.nih.gov](https://pubmed.ncbi.nlm.nih.gov)]
- To cite this document: BenchChem. [Independent Verification of SARS-CoV-2 nsp16 Inhibitors: A Comparative Guide]. BenchChem, [2025]. [Online PDF]. Available at: [<https://www.benchchem.com/product/b12417908#independent-verification-of-published-data-on-sars-cov-2-nsp16-inhibitors>]

Disclaimer & Data Validity:

The information provided in this document is for Research Use Only (RUO) and is strictly not intended for diagnostic or therapeutic procedures. While BenchChem strives to provide accurate protocols, we make no warranties, express or implied, regarding the fitness of this product for every specific experimental setup.

Technical Support: The protocols provided are for reference purposes. Unsure if this reagent suits your experiment? [[Contact our Ph.D. Support Team for a compatibility check](#)]

Need Industrial/Bulk Grade? [Request Custom Synthesis Quote](#)

BenchChem

Our mission is to be the trusted global source of essential and advanced chemicals, empowering scientists and researchers to drive progress in science and industry.

Contact

Address: 3281 E Guasti Rd
Ontario, CA 91761, United States
Phone: (601) 213-4426
Email: info@benchchem.com