

# Application Notes: Characterization of Selective CDK9 Inhibitors in Cell-Based Assays

**Author:** BenchChem Technical Support Team. **Date:** April 2026

## Compound of Interest

Compound Name: *Cdk9-IN-14*

Cat. No.: *B12417532*

[Get Quote](#)

## Introduction

Cyclin-dependent kinase 9 (CDK9) is a key regulator of transcriptional elongation. As the catalytic subunit of the Positive Transcription Elongation Factor b (P-TEFb) complex, CDK9 phosphorylates the C-terminal domain of RNA Polymerase II (RNAPII), facilitating the transition from paused to productive transcriptional elongation. Dysregulation of CDK9 activity is implicated in various malignancies, making it a compelling therapeutic target. The inhibition of CDK9 leads to the downregulation of short-lived anti-apoptotic proteins, such as MCL-1 and MYC, thereby inducing apoptosis in cancer cells.

These application notes provide a comprehensive guide for the cellular characterization of selective CDK9 inhibitors. While the specific compound "**Cdk9-IN-14**" is not extensively documented in public literature, the protocols and principles outlined here are applicable to any potent and selective CDK9 inhibitor, such as MC180295 or AZD4573. This document offers detailed methodologies for assessing a compound's anti-proliferative and pro-apoptotic activity, as well as for confirming its on-target mechanism of action in a cellular context.

Mechanism of Action: CDK9 in Transcriptional Elongation

CDK9, in complex with its regulatory partner Cyclin T1, forms the active P-TEFb complex. This complex is recruited to promoter-proximal regions where RNAPII has paused after initiating transcription. The kinase activity of CDK9 is essential for releasing this pause. CDK9 phosphorylates Serine 2 (Ser2) residues on the C-terminal domain (CTD) of RNAPII and also phosphorylates negative elongation factors like the DRB Sensitivity-Inducing Factor (DSIF) and Negative Elongation Factor (NELF).[1] These phosphorylation events cause the dissociation of NELF and convert DSIF into a positive elongation factor, allowing RNAPII to proceed with productive transcript elongation. Selective inhibitors of CDK9 block this process, leading to a global transcription suppression, particularly affecting genes with high transcriptional turnover, such as key oncogenes.

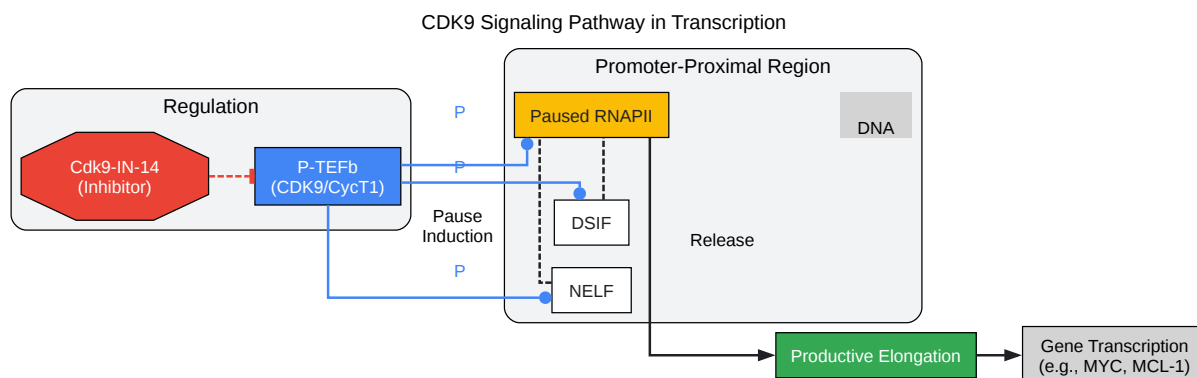

### Cell Proliferation Assay Workflow (MTS)

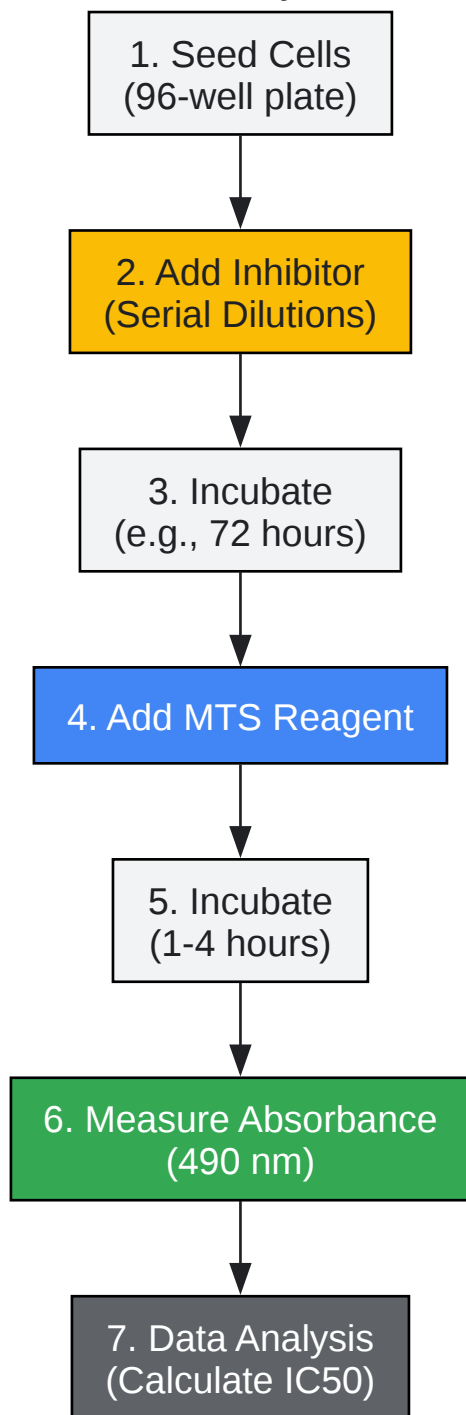

## Apoptosis Assay Workflow (Annexin V/PI)

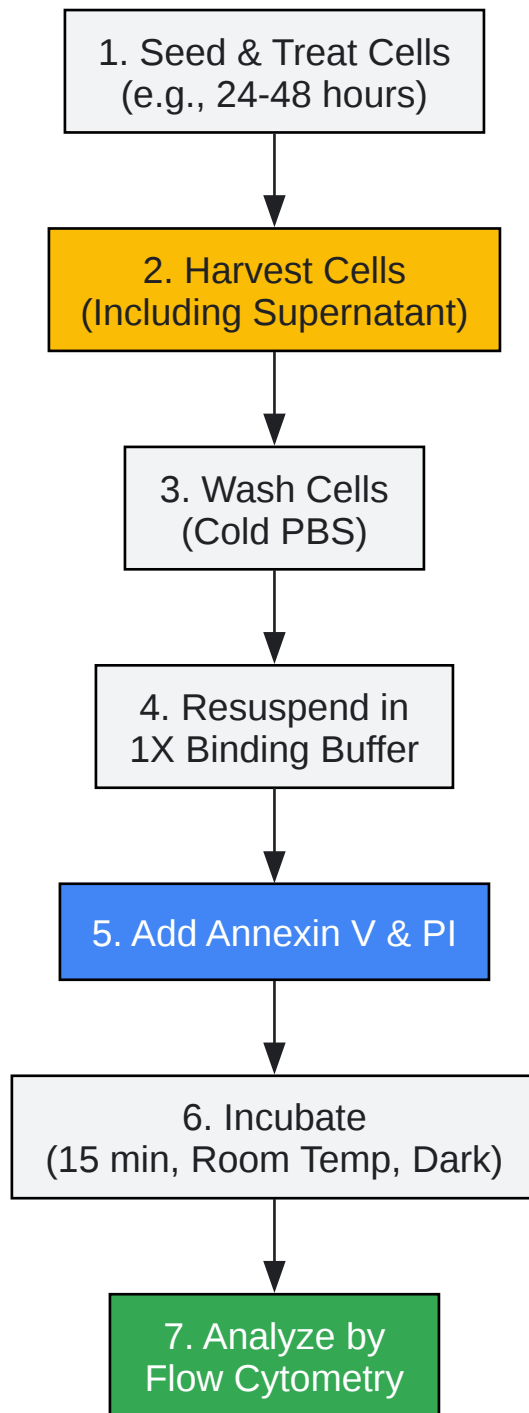

## Western Blot Workflow for Target Modulation

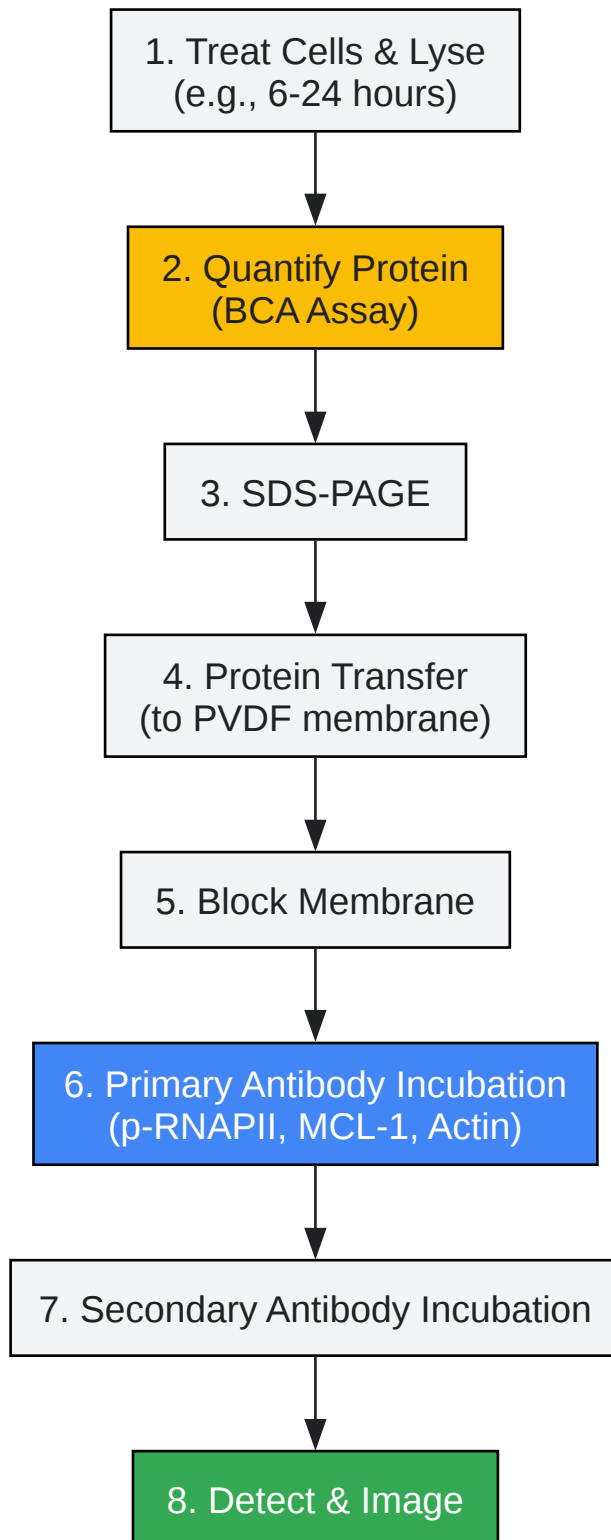

[Click to download full resolution via product page](#)

### Need Custom Synthesis?

BenchChem offers custom synthesis for rare earth carbides and specific isotopic labeling.

Email: [info@benchchem.com](mailto:info@benchchem.com) or [Request Quote Online](#).

## References

- 1. Pharmacological perturbation of CDK9 using selective CDK9 inhibition or degradation - PMC [[pmc.ncbi.nlm.nih.gov](https://pubmed.ncbi.nlm.nih.gov/)]
- To cite this document: BenchChem. [Application Notes: Characterization of Selective CDK9 Inhibitors in Cell-Based Assays]. BenchChem, [2026]. [Online PDF]. Available at: [<https://www.benchchem.com/product/b12417532/docs#application-notes-characterization-of-selective-cdk9-inhibitors-in-cell-based-assays>]

### Disclaimer & Data Validity:

The information provided in this document is for Research Use Only (RUO) and is strictly not intended for diagnostic or therapeutic procedures. While BenchChem strives to provide accurate protocols, we make no warranties, express or implied, regarding the fitness of this product for every specific experimental setup.

**Technical Support:** The protocols provided are for reference purposes. Unsure if this reagent suits your experiment?

**Need Industrial/Bulk Grade?** [Request Custom Synthesis Quote](#)

## BenchChem

Our mission is to be the trusted global source of essential and advanced chemicals, empowering scientists and researchers to drive progress in science and industry.

### Contact

Address: 3281 E Guasti Rd  
Ontario, CA 91761, United States  
Phone: (601) 213-4426  
Email: [info@benchchem.com](mailto:info@benchchem.com)

Contact our Ph.D. Support Team for a compatibility check