

Technical Support Center: Improving the Oral Bioavailability of Btk-IN-9

Author: BenchChem Technical Support Team. **Date:** April 2026

Compound of Interest

Compound Name: *Btk-IN-9*
Cat. No.: *B12416190*

[Get Quote](#)

This technical support center provides researchers, scientists, and drug development professionals with troubleshooting guides and frequently asked questions (FAQs) to address challenges encountered during the oral formulation development of **Btk-IN-9**, a potent Bruton's tyrosine kinase (BTK) inhibitor. Due to its poor aqueous solubility, enhancing the oral bioavailability of **Btk-IN-9** is a critical step in its development as a therapeutic agent.

Frequently Asked Questions (FAQs)

1. What are the main challenges associated with the oral administration of **Btk-IN-9**?

The primary challenge for the oral delivery of **Btk-IN-9** is its low aqueous solubility. A product page for a similar compound, Btk-IN-1, indicates it is insoluble in water and ethanol[1]. Poor solubility often leads to a low dissolution rate in the gastrointestinal (GI) tract, which in turn results in low and variable oral bioavailability[2][3]. For a drug to be absorbed into the bloodstream, it must first be dissolved in the GI fluids.

2. What are the common formulation strategies to improve the oral bioavailability of poorly soluble drugs like **Btk-IN-9**?

Several formulation strategies can be employed to enhance the oral bioavailability of poorly soluble compounds. These include:

- **Particle Size Reduction:** Increasing the surface area of the drug by reducing its particle size can enhance the dissolution rate. Techniques like micronization and nanosuspension fall under this category[4].
- **Amorphous Solid Dispersions (ASDs):** Dispersing the drug in its amorphous (non-crystalline) state within a polymer matrix can significantly improve its solubility and dissolution rate[5][6][7][8].
- **Lipid-Based Formulations:** Incorporating the drug into lipid-based systems such as Self-Emulsifying Drug Delivery Systems (SEDDS) can improve its solubilization in the GI tract[9].
- **Complexation:** Using complexing agents like cyclodextrins can increase the solubility of the drug by forming inclusion complexes.

3. How can I assess the permeability of my **Btk-IN-9** formulation?

The Caco-2 cell permeability assay is a widely used in vitro model to predict the intestinal absorption of drugs[10][11][12]. This assay uses a monolayer of human colon adenocarcinoma cells (Caco-2) that differentiate to form tight junctions, mimicking the intestinal barrier[12]. The apparent permeability coefficient (P_{app}) of a compound across the Caco-2 monolayer can be determined and is a good indicator of its potential for oral absorption[10][13].

4. What are the key pharmacokinetic parameters to evaluate when assessing the oral bioavailability of a new **Btk-IN-9** formulation?

In vivo studies, typically in animal models like rats, are essential to determine the oral bioavailability of a formulation. The key pharmacokinetic parameters to measure from plasma concentration-time profiles are:

- **Area Under the Curve (AUC):** Represents the total drug exposure over time. A higher AUC for an oral formulation compared to an intravenous (IV) dose indicates better bioavailability.
- **Maximum Plasma Concentration (C_{max}):** The highest concentration of the drug reached in the plasma.

- Time to Maximum Plasma Concentration (T_{max}): The time at which C_{max} is observed.
- Absolute Bioavailability (F%): Calculated by comparing the AUC of the oral dose to the AUC of an IV dose.

Troubleshooting Guides

This section provides solutions to common problems encountered during the development of oral formulations for **Btk-IN-9**.

Problem	Possible Causes	Recommended Solutions
Low in vitro dissolution of Btk-IN-9 formulation.	<p>Inadequate solubility enhancement by the chosen formulation strategy. Drug recrystallization in the dissolution medium.</p> <p>Insufficient wetting of the drug particles.</p>	<p>- Optimize the formulation: For solid dispersions, screen different polymers and drug-to-polymer ratios. For nanosuspensions, optimize the stabilizer and homogenization process.</p> <p>- Incorporate a precipitation inhibitor in the formulation.</p> <p>- Add a surfactant to the dissolution medium to improve wetting.</p>
High variability in in vivo pharmacokinetic data.	<p>Food effects influencing drug absorption. Inconsistent dosing procedure. Poor formulation stability leading to variable drug release.</p>	<p>- Conduct pharmacokinetic studies in both fasted and fed states to assess the food effect.</p> <p>- Ensure a consistent and accurate oral gavage technique.</p> <p>- Perform stability studies on the formulation to ensure its physical and chemical integrity over time.</p>
Low oral bioavailability despite good in vitro dissolution.	<p>High first-pass metabolism in the liver or gut wall. Efflux transporter activity (e.g., P-glycoprotein) pumping the drug back into the GI tract. Poor membrane permeability.</p>	<p>- Investigate the metabolic stability of Btk-IN-9 using liver microsomes or hepatocytes.</p> <p>- Conduct Caco-2 permeability assays in the presence and absence of efflux transporter inhibitors to assess the role of efflux.</p> <p>- If permeability is the limiting factor, consider prodrug approaches or the use of permeation enhancers.</p>
Precipitation of the drug in the GI tract upon oral administration.	<p>The supersaturated state created by an enabling formulation is not maintained</p>	<p>- Incorporate precipitation inhibitors (e.g., HPMC, PVP) into the formulation to maintain</p>

in the GI fluids. pH-dependent solubility of Btk-IN-9.

the supersaturated state. - Characterize the pH-solubility profile of Btk-IN-9 and select polymers for solid dispersions that provide optimal release at different intestinal pH values.

Quantitative Data Summary

Since specific oral pharmacokinetic data for **Btk-IN-9** is not publicly available, the following tables present representative data for other BTK inhibitors to illustrate how quantitative results can be structured.

Table 1: Physicochemical Properties of a Representative BTK Inhibitor (Btk-IN-1)

Parameter	Value	Reference
Molecular Weight	384.8 g/mol	[1]
IC50 (BTK)	<100 nM	[1]
Solubility (Water)	Insoluble	[1]
Solubility (Ethanol)	Insoluble	[1]
Solubility (DMSO)	77 mg/mL	[1]

Table 2: Representative Oral Pharmacokinetic Parameters of a BTK Inhibitor (Compound 9) in Rats

Data presented as mean \pm s.d., n=3. Oral dose: 40 mg/kg.

Parameter	Value	Reference
C _{max} (ng/mL)	104 ± 66	[14]
T _{max} (hr)	1	[14]
Plasma Concentration at 6 hr (ng/mL)	24 ± 17	[14]
Plasma Concentration at 14 hr (ng/mL)	3 ± 3	[14]

Table 3: Example of Improved Bioavailability with a Nanosuspension Formulation of a Poorly Soluble Kinase Inhibitor (MTKi-327)

Formulation	Route	AUC _{0-∞} (μg·h/mL)	Bioavailability Improvement	Reference
Captisol Solution	Oral	12.3	-	[15][16]
Nanosuspension	Oral	29.5	2.4-fold	[15][16]
Captisol Solution	IV	45.6	-	[15][16]
Nanosuspension	IV	109.4	2.4-fold	[15][16]

Experimental Protocols

Protocol 1: Preparation of Btk-IN-9 Amorphous Solid Dispersion (ASD) by Solvent Evaporation

Objective: To prepare an amorphous solid dispersion of **Btk-IN-9** to improve its dissolution rate.

Materials:

- **Btk-IN-9**
- Polymer (e.g., PVP K30, HPMC-AS, Soluplus®)
- Organic solvent (e.g., dichloromethane, methanol, acetone)

- Rotary evaporator
- Vacuum oven

Methodology:

- Weigh the desired amounts of **Btk-IN-9** and the selected polymer (e.g., 1:4 drug-to-polymer ratio).
- Dissolve both **Btk-IN-9** and the polymer in a suitable organic solvent in a round-bottom flask. Ensure complete dissolution.
- Remove the solvent using a rotary evaporator at a controlled temperature (e.g., 40°C) and reduced pressure.
- A thin film of the solid dispersion will form on the wall of the flask.
- Further dry the solid dispersion in a vacuum oven at a specified temperature (e.g., 40-50°C) for 24-48 hours to remove any residual solvent.
- Scrape the dried solid dispersion from the flask and store it in a desiccator.
- Characterize the prepared ASD for its amorphous nature (using techniques like XRD and DSC) and perform in vitro dissolution studies.

Protocol 2: In Vivo Oral Bioavailability Study in Rats

Objective: To determine the pharmacokinetic profile and oral bioavailability of a **Btk-IN-9** formulation.

Materials:

- **Btk-IN-9** formulation
- Sprague-Dawley rats (male, 8-10 weeks old)
- Oral gavage needles
- Blood collection tubes (e.g., with K2EDTA)

- Centrifuge
- LC-MS/MS system for bioanalysis

Methodology:

- Fast the rats overnight (with free access to water) before dosing.
- Administer the **Btk-IN-9** formulation orally via gavage at a specific dose (e.g., 10 mg/kg). For absolute bioavailability, a separate group will receive an intravenous (IV) dose.
- Collect blood samples (approximately 0.25 mL) from the tail vein or another appropriate site at predetermined time points (e.g., 0, 0.25, 0.5, 1, 2, 4, 6, 8, and 24 hours post-dose)[17].
- Centrifuge the blood samples to separate the plasma.
- Store the plasma samples at -80°C until analysis.
- Quantify the concentration of **Btk-IN-9** in the plasma samples using a validated LC-MS/MS method.
- Calculate the pharmacokinetic parameters (AUC, C_{max}, T_{max}) using appropriate software.
- Calculate the absolute oral bioavailability (F%) using the formula: $F\% = (AUC_{oral} / AUC_{IV}) * (Dose_{IV} / Dose_{oral}) * 100$.

Visualizations

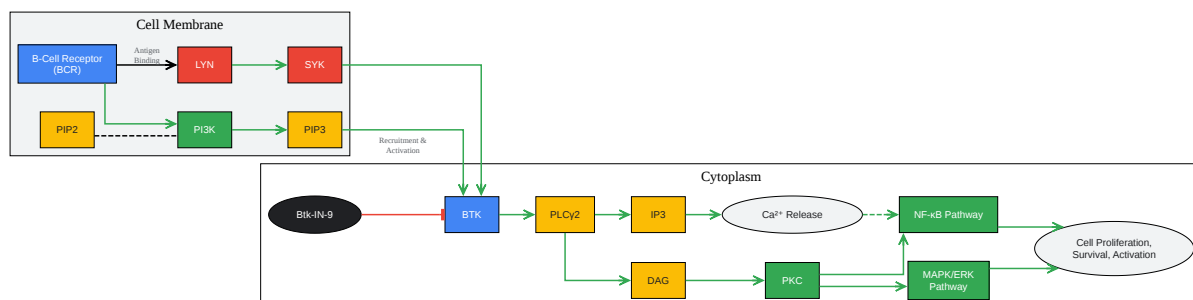

[Click to download full resolution via product page](#)

Caption: Bruton's Tyrosine Kinase (BTK) Signaling Pathway and the inhibitory action of **Btk-IN-9**.

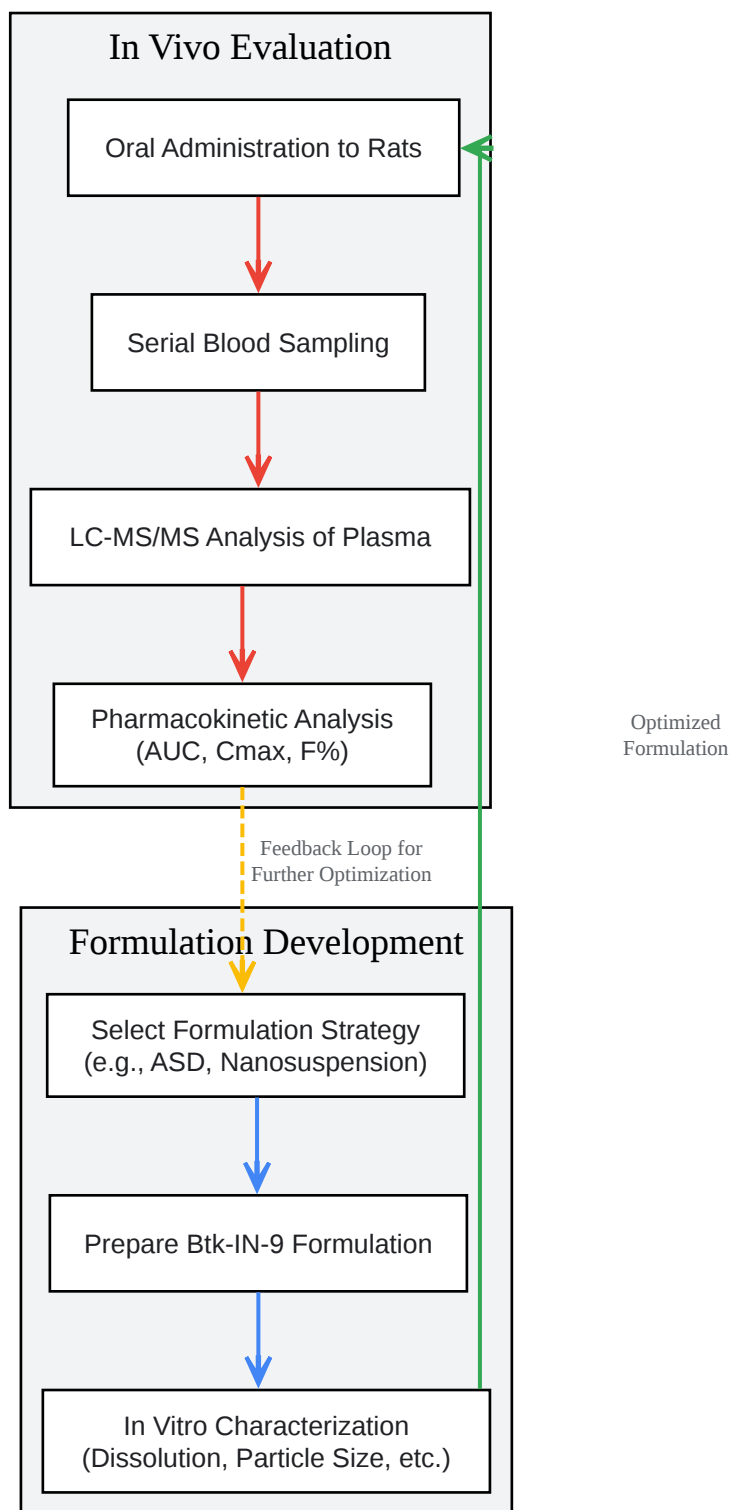

[Click to download full resolution via product page](#)

Caption: Experimental workflow for developing and evaluating an oral formulation of **Btk-IN-9**.

Need Custom Synthesis?

BenchChem offers custom synthesis for rare earth carbides and specific isotopic labeling.

Email: info@benchchem.com or [Request Quote Online](#).

References

- [1. selleckchem.com \[selleckchem.com\]](https://www.selleckchem.com)
- [2. Investigation of Dose-Dependent Factors Limiting Oral Bioavailability: Case Study With the PI3K- \$\delta\$ Inhibitor - PubMed \[pubmed.ncbi.nlm.nih.gov\]](#)
- [3. pubs.acs.org \[pubs.acs.org\]](https://pubs.acs.org)
- [4. Nanosuspension: An approach to enhance solubility of drugs - PMC \[pmc.ncbi.nlm.nih.gov\]](#)
- [5. Ibrutinib amorphous solid dispersions with enhanced dissolution at colonic pH for the localized treatment of colorectal cancer - PubMed \[pubmed.ncbi.nlm.nih.gov\]](#)
- [6. Solid Dispersion Oral Thin Film Preparation Technology - Oral Thin Film - CD Formulation \[formulationbio.com\]](#)
- [7. mdpi.com \[mdpi.com\]](https://www.mdpi.com)
- [8. DSpace \[research-repository.griffith.edu.au\]](https://research-repository.griffith.edu.au)
- [9. Enhancing the Oral Absorption of Kinase Inhibitors Using Lipophilic Salts and Lipid-Based Formulations - PubMed \[pubmed.ncbi.nlm.nih.gov\]](#)
- [10. Determination of drug permeability and prediction of drug absorption in Caco-2 monolayers - PubMed \[pubmed.ncbi.nlm.nih.gov\]](#)
- [11. youtube.com \[youtube.com\]](https://www.youtube.com)
- [12. Caco-2 cell permeability assays to measure drug absorption - PubMed \[pubmed.ncbi.nlm.nih.gov\]](#)
- [13. Predicting apparent passive permeability of Caco-2 and MDCK cell-monolayers: A mechanistic model | PLOS One \[journals.plos.org\]](#)
- [14. researchgate.net \[researchgate.net\]](https://www.researchgate.net)
- [15. Nanosuspension for the delivery of a poorly soluble anti-cancer kinase inhibitor - PubMed \[pubmed.ncbi.nlm.nih.gov\]](#)
- [16. researchgate.net \[researchgate.net\]](https://www.researchgate.net)

- [17. webstor.srmist.edu.in](http://webstor.srmist.edu.in) [webstor.srmist.edu.in]
- To cite this document: BenchChem. [Technical Support Center: Improving the Oral Bioavailability of Btk-IN-9]. BenchChem, [2026]. [Online PDF]. Available at: [<https://www.benchchem.com/product/b12416190/docs#technical-support-center-improving-the-oral-bioavailability-of-btk-in-9>]

Disclaimer & Data Validity:

The information provided in this document is for Research Use Only (RUO) and is strictly not intended for diagnostic or therapeutic procedures. While BenchChem strives to provide accurate protocols, we make no warranties, express or implied, regarding the fitness of this product for every specific experimental setup.

Technical Support: The protocols provided are for reference purposes. Unsure if this reagent suits your experiment?

Need Industrial/Bulk Grade? [Request Custom Synthesis Quote](#)

BenchChem

Our mission is to be the trusted global source of essential and advanced chemicals, empowering scientists and researchers to drive progress in science and industry.

Contact

Address: 3281 E Guasti Rd
Ontario, CA 91761, United States
Phone: (601) 213-4426
Email: info@benchchem.com

[Contact our Ph.D. Support Team for a compatibility check](#)