

The Effect of PRMT7 Inhibition on Histone Methylation: A Technical Guide

Author: BenchChem Technical Support Team. **Date:** April 2026

Compound of Interest

Compound Name: *Prmt7-IN-1*

Cat. No.: *B12415031*

[Get Quote](#)

For Researchers, Scientists, and Drug Development Professionals

Introduction

Protein Arginine Methyltransferase 7 (PRMT7) is a unique member of the PRMT family, classified as a type III enzyme that exclusively catalyzes the formation of monomethylarginine (MMA).[1][2] This distinct enzymatic activity sets it apart from other PRMTs that can produce symmetric or asymmetric dimethylarginine. PRMT7 plays a crucial role in a variety of cellular processes, including transcriptional regulation, DNA damage response, RNA splicing, and the maintenance of pluripotency, by methylating both histone and non-histone protein substrates. [1][3][4]

Histone proteins are primary targets of PRMT7, and the resulting monomethylation of specific arginine residues contributes to the complex epigenetic landscape that governs gene expression. Understanding the impact of PRMT7 inhibition on histone methylation is therefore critical for elucidating its biological functions and for the development of novel therapeutic agents targeting epigenetic pathways.

This technical guide provides an in-depth overview of the effects of a representative PRMT7 inhibitor, **PRMT7-IN-1** (exemplified by the well-characterized inhibitor SGC8158), on histone

methylation. It includes a summary of quantitative data, detailed experimental protocols, and visualizations of key pathways and workflows to support researchers in this field.

PRMT7-IN-1: A Potent and Selective Inhibitor of PRMT7

For the purpose of this guide, "PRMT7-IN-1" will refer to the potent and selective, SAM-competitive inhibitor SGC8158.^{[5][6]} SGC8158 and its cell-permeable prodrug, SGC3027, are invaluable tools for studying the cellular functions of PRMT7.^{[3][5]}

Quantitative Data on PRMT7-IN-1 (SGC8158) Activity

The following tables summarize the available quantitative data for the PRMT7 inhibitor SGC8158 and its effects.

Inhibitor	Target	IC50 (nM)	Assay Type	Reference
SGC8158	PRMT7	<2.5	in vitro enzymatic assay	[7]
SGC8158	PRMT1	>10,000	in vitro enzymatic assay	[7]
SGC8158	PRMT3	>10,000	in vitro enzymatic assay	[7]
SGC8158	CARM1 (PRMT4)	1,500	in vitro enzymatic assay	[7]
SGC8158	PRMT5	2,700	in vitro enzymatic assay	[7]
SGC8158	PRMT6	>10,000	in vitro enzymatic assay	[7]
SGC8158	PRMT8	>10,000	in vitro enzymatic assay	[7]
SGC8158	PRMT9	4,200	in vitro enzymatic assay	[7]
SGC8158	SETD2	>10,000	in vitro enzymatic assay	[7]
SGC8158	SUV39H2	>10,000	in vitro enzymatic assay	[7]

Table 1: In vitro inhibitory activity of SGC8158 against a panel of protein methyltransferases.

Compound	Cell Line	Target	Effect	IC50 (µM)	Reference
SGC3027 (prodrug)	C2C12	HSP70 monomethylation	Reduction of monomethylation	~2.4	[3]

Table 2:
Cellular activity of the PRMT7 inhibitor prodrug SGC3027.

Note: While histones are established substrates of PRMT7, specific quantitative data detailing the percentage or fold-change reduction of histone methylation marks upon treatment with SGC8158 is not readily available in the public domain. The known histone substrates of PRMT7 are the primary targets expected to be affected by this inhibitor.

Histone Substrates of PRMT7

PRMT7 monomethylates specific arginine residues on several core histones. These modifications play a role in regulating chromatin structure and gene expression.

Histone	Residue(s)	Methylation Type	Reference
H2A	R3	Monomethylation	[3]
H2B	R29, R31, R33	Monomethylation	[8]
H3	R2	Monomethylation	[1]
H4	R3, R17, R19	Monomethylation	[8]

Table 3: Known histone arginine methylation sites targeted by PRMT7.

Signaling Pathways and Logical Relationships

The following diagrams illustrate the role of PRMT7 in histone methylation and gene regulation, as well as a typical experimental workflow for studying a PRMT7 inhibitor.

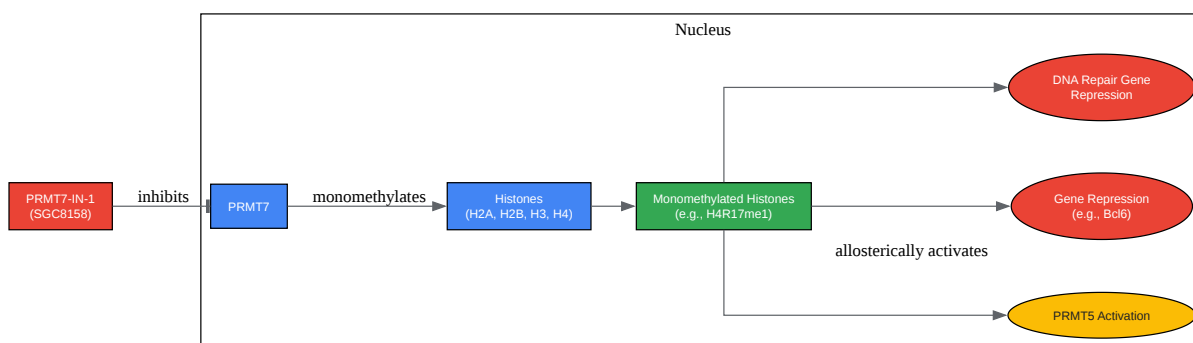

[Click to download full resolution via product page](#)

PRMT7 signaling pathway in histone methylation and gene regulation.

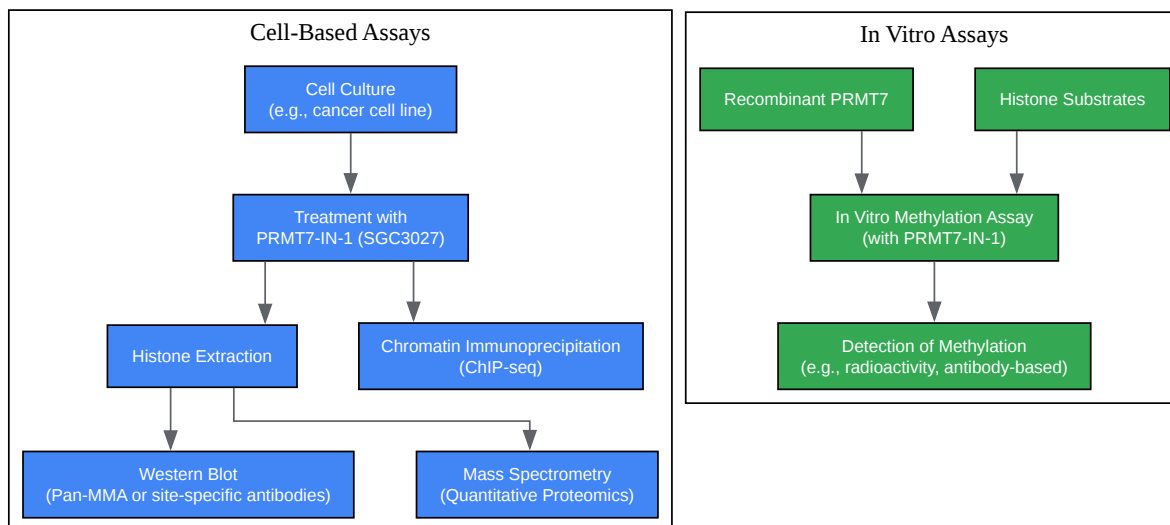

[Click to download full resolution via product page](#)

Experimental workflow for studying the effect of **PRMT7-IN-1** on histone methylation.

Experimental Protocols

Detailed methodologies are crucial for the accurate assessment of **PRMT7-IN-1**'s effect on histone methylation. Below are outlines of key experimental protocols.

In Vitro Histone Methyltransferase (HMT) Assay

This assay directly measures the enzymatic activity of PRMT7 on histone substrates and the inhibitory effect of **PRMT7-IN-1**.

a. Materials:

- Recombinant human PRMT7
- Histone substrates (e.g., recombinant histone H2B, H4, or specific peptides)

- S-adenosyl-L-[methyl-³H]-methionine ([³H]-SAM) as the methyl donor
- **PRMT7-IN-1** (SGC8158) dissolved in a suitable solvent (e.g., DMSO)
- Assay buffer (e.g., 50 mM HEPES pH 7.5, 10 mM NaCl, 1 mM DTT)
- Scintillation fluid and counter

b. Protocol:

- Prepare reaction mixtures in a 96-well plate. Each reaction should contain the assay buffer, a fixed concentration of recombinant PRMT7, and the histone substrate.
- Add varying concentrations of **PRMT7-IN-1** (SGC8158) to the wells to determine the IC₅₀ value. Include a vehicle control (DMSO).
- Initiate the reaction by adding [³H]-SAM.
- Incubate the plate at 30°C for a defined period (e.g., 1-2 hours).
- Stop the reaction by adding an equal volume of 20% trichloroacetic acid (TCA).
- Transfer the reaction mixture to a filter paper, and wash with 10% TCA and then ethanol to remove unincorporated [³H]-SAM.
- Measure the incorporated radioactivity on the filter paper using a scintillation counter.
- Calculate the percentage of inhibition at each inhibitor concentration and determine the IC₅₀ value using appropriate software.

Western Blot Analysis of Histone Methylation

This method allows for the semi-quantitative assessment of changes in global or specific histone arginine monomethylation in cells treated with a PRMT7 inhibitor.

a. Materials:

- Cell line of interest

- **PRMT7-IN-1** prodrug (SGC3027)
- Cell lysis buffer and histone extraction buffers
- Primary antibodies: anti-pan-monomethylarginine, and specific antibodies against histone marks (e.g., anti-H4R17me1, if available) and loading controls (e.g., anti-Histone H3).
- Secondary antibodies conjugated to HRP
- Chemiluminescence substrate and imaging system

b. Protocol:

- Culture cells to the desired confluency and treat with various concentrations of SGC3027 for a specific duration (e.g., 48-72 hours).
- Harvest the cells and perform histone extraction using an acid extraction protocol.
- Quantify the protein concentration of the histone extracts.
- Separate the histone proteins by SDS-PAGE and transfer them to a PVDF membrane.
- Block the membrane and incubate with the primary antibody overnight at 4°C.
- Wash the membrane and incubate with the appropriate HRP-conjugated secondary antibody.
- Develop the blot using a chemiluminescence substrate and capture the image.
- Quantify the band intensities and normalize to the loading control to determine the relative change in histone methylation.

Chromatin Immunoprecipitation followed by Sequencing (ChIP-seq)

ChIP-seq provides a genome-wide map of specific histone methylation marks, revealing how PRMT7 inhibition alters the epigenetic landscape at specific gene loci.

a. Materials:

- Cells treated with **PRMT7-IN-1** prodrug (SGC3027) or vehicle control
- Formaldehyde for cross-linking
- CHIP-grade antibodies against specific histone methylation marks (e.g., H4R3me1)
- Buffers for cell lysis, chromatin shearing, immunoprecipitation, washing, and elution
- Protein A/G magnetic beads
- Reagents for reverse cross-linking and DNA purification
- Reagents and equipment for next-generation sequencing library preparation and sequencing

b. Protocol:

- Cross-link proteins to DNA in treated and control cells using formaldehyde.
- Lyse the cells and shear the chromatin to fragments of 200-500 bp using sonication or enzymatic digestion.
- Immunoprecipitate the chromatin fragments using an antibody specific to the histone mark of interest.
- Wash the beads to remove non-specifically bound chromatin.
- Elute the immunoprecipitated chromatin and reverse the cross-links.
- Purify the DNA.
- Prepare sequencing libraries from the CHIP DNA and input control DNA.
- Perform high-throughput sequencing.
- Analyze the sequencing data to identify regions with differential enrichment of the histone mark between treated and control samples.

Mass Spectrometry-based Proteomic Analysis

Quantitative mass spectrometry offers a highly sensitive and unbiased method to identify and quantify changes in histone methylation at a global level.

a. Materials:

- Histone extracts from cells treated with **PRMT7-IN-1** prodrug (SGC3027) or vehicle control
- Enzymes for protein digestion (e.g., trypsin, Arg-C)
- Reagents for peptide labeling (e.g., SILAC, iTRAQ, TMT) for quantitative analysis
- Liquid chromatography-tandem mass spectrometry (LC-MS/MS) system
- Software for data analysis and quantification of post-translational modifications

b. Protocol:

- Extract histones from treated and control cells. For quantitative analysis, stable isotope labeling (e.g., SILAC) can be performed during cell culture.
- Digest the histone proteins into peptides using appropriate proteases.
- (Optional) Enrich for methylated peptides using specific antibodies or other affinity-based methods.
- Analyze the peptide mixture by LC-MS/MS.
- Process the raw data using specialized software to identify peptides and their modifications.
- Quantify the relative abundance of specific methylated peptides between the treated and control samples to determine the effect of the inhibitor on histone methylation levels.

Conclusion

PRMT7 is a key epigenetic modulator, and its inhibition presents a promising avenue for therapeutic intervention in various diseases. The selective inhibitor **PRMT7-IN-1** (SGC8158) serves as a critical tool for dissecting the cellular roles of PRMT7-mediated histone monomethylation. While the direct histone substrates of PRMT7 are well-documented, further

research employing the advanced proteomic and genomic techniques outlined in this guide is necessary to quantitatively delineate the precise impact of PRMT7 inhibition on the histone code and its downstream consequences on gene expression and cellular function. This in-depth technical guide provides a foundational framework for researchers to design and execute experiments aimed at furthering our understanding of this important epigenetic writer and the therapeutic potential of its inhibition.

Need Custom Synthesis?

BenchChem offers custom synthesis for rare earth carbides and specific isotopic labeling.

Email: info@benchchem.com or [Request Quote Online](#).

References

- [1. PRMT7 Inhibitor SGC8158 Enhances Doxorubicin-Induced DNA Damage and Its Cytotoxicity - PMC \[pmc.ncbi.nlm.nih.gov\]](#)
- [2. Protein arginine methyltransferase 5 \(Prmt5\) localizes to chromatin loop anchors and modulates expression of genes at TAD boundaries during early adipogenesis \[elifesciences.org\]](#)
- [3. biorxiv.org \[biorxiv.org\]](#)
- [4. Quantitative proteomic analysis of histone modifications - PubMed \[pubmed.ncbi.nlm.nih.gov\]](#)
- [5. Pharmacological inhibition of PRMT7 links arginine monomethylation to the cellular stress response - PubMed \[pubmed.ncbi.nlm.nih.gov\]](#)
- [6. researchgate.net \[researchgate.net\]](#)
- [7. medscape.com \[medscape.com\]](#)
- [8. PRMT7 as a unique member of the protein arginine methyltransferase family: A review - PMC \[pmc.ncbi.nlm.nih.gov\]](#)
- To cite this document: BenchChem. [The Effect of PRMT7 Inhibition on Histone Methylation: A Technical Guide]. BenchChem, [2026]. [Online PDF]. Available at: [\[https://www.benchchem.com/product/b12415031/docs#the-effect-of-prmt7-inhibition-on-histone-methylation-a-technical-guide\]](https://www.benchchem.com/product/b12415031/docs#the-effect-of-prmt7-inhibition-on-histone-methylation-a-technical-guide)

Disclaimer & Data Validity:

The information provided in this document is for Research Use Only (RUO) and is strictly not intended for diagnostic or therapeutic procedures. While BenchChem strives to provide accurate protocols, we make no warranties, express or implied, regarding the fitness of this product for every specific experimental setup.

Technical Support: The protocols provided are for reference purposes. Unsure if this reagent suits your experiment?

Need Industrial/Bulk Grade? [Request Custom Synthesis Quote](#)

BenchChem

Our mission is to be the trusted global source of essential and advanced chemicals, empowering scientists and researchers to drive progress in science and industry.

Contact

Address: 3281 E Guasti Rd
Ontario, CA 91761, United States
Phone: (601) 213-4426
Email: info@benchchem.com

[Contact our Ph.D. Support Team for a compatibility check](#)