

SSTR4 agonist 2 experimental variability and solutions

Author: BenchChem Technical Support Team. **Date:** April 2026

Compound of Interest

Compound Name: SSTR4 agonist 2

Cat. No.: B12414300

[Get Quote](#)

SSTR4 Agonist Experimental Support Center

This technical support center provides researchers, scientists, and drug development professionals with comprehensive troubleshooting guides and frequently asked questions (FAQs) to address experimental variability when working with Somatostatin Receptor 4 (SSTR4) agonists.

Frequently Asked Questions (FAQs)

Q1: What are the primary signaling pathways activated by SSTR4 agonists?

SSTR4 is a G protein-coupled receptor (GPCR) that primarily couples to the Gi/o family of G proteins.[1] Upon agonist binding, the activated G α i/o subunit inhibits adenylyl cyclase, leading to a decrease in intracellular cyclic AMP (cAMP) levels.[2][3] Additionally, SSTR4 activation can lead to the modulation of other signaling pathways, including the activation of the mitogen-activated protein kinase (MAPK/ERK) cascade and the release of arachidonic acid.[2] Some evidence also suggests that SSTR4 may influence ion channels, such as G protein-coupled inwardly rectifying potassium channels (GIRKs), leading to neuronal hyperpolarization.[4]

Q2: What are the common sources of experimental variability when working with SSTR4 agonists?

Experimental variability in SSTR4 agonist assays can arise from several factors:

- Cell-based factors: Cell line authenticity, passage number, receptor expression levels, and overall cell health can significantly impact results.
- Agonist-related issues: Purity, solubility, and stability of the SSTR4 agonist are critical. Peptide agonists, in particular, can be susceptible to degradation.
- Assay conditions: Variations in buffer composition, incubation times, temperature, and the specific reagents used (e.g., forskolin concentration in cAMP assays) can lead to inconsistent data.
- Receptor pharmacology: SSTR4 can exhibit biased agonism, where different agonists stabilize distinct receptor conformations, leading to preferential activation of certain signaling pathways over others. Furthermore, the presence of other somatostatin receptor subtypes in the experimental system can lead to off-target effects if the agonist is not sufficiently selective.
- Data analysis: The choice of data analysis methods and inappropriate curve fitting can lead to inaccurate determination of parameters like EC50 and Ki.

Q3: What is biased agonism and how does it affect SSTR4 agonist experiments?

Biased agonism, also known as functional selectivity, is a phenomenon where an agonist preferentially activates one signaling pathway over another downstream of the same receptor. For SSTR4, a biased agonist might, for example, potently inhibit cAMP production (a G protein-mediated event) but be less effective at recruiting β -arrestin. This can lead to variability in experimental outcomes depending on the specific endpoint being measured. It is crucial to characterize SSTR4 agonists across multiple functional assays to fully understand their signaling profile.

Q4: How can I ensure the selectivity of my SSTR4 agonist?

Ensuring agonist selectivity is crucial, as the five somatostatin receptor subtypes share significant sequence homology. To confirm selectivity, it is recommended to:

- Test against all SSTR subtypes: Profile the agonist's activity against all five human somatostatin receptors (SSTR1-5) in parallel assays.
- Use selective antagonists: Employ well-characterized selective antagonists for other SSTR subtypes to block potential off-target effects.
- Consult literature data: Refer to published studies for the selectivity profile of the specific agonist being used. For example, the small molecule agonist J-2156 is reported to be highly selective for SSTR4 over other subtypes.

Troubleshooting Guides

cAMP Assays

Problem: High basal cAMP levels in the absence of an agonist.

Possible Cause	Solution
Constitutive receptor activity: High receptor expression levels can lead to agonist-independent signaling.	Use a cell line with lower or inducible SSTR4 expression.
Cell stress: Suboptimal cell culture conditions can elevate basal cAMP.	Ensure proper cell culture maintenance, including appropriate media, serum, and incubator conditions. Avoid over-confluency.
Phosphodiesterase (PDE) inhibitor issues: The PDE inhibitor (e.g., IBMX) concentration may be too high.	Titrate the PDE inhibitor to the lowest effective concentration that provides a sufficient assay window.

Problem: Weak or no inhibition of forskolin-stimulated cAMP by the SSTR4 agonist.

Possible Cause	Solution
Low receptor expression or function: The cell line may not have sufficient functional SSTR4.	Verify SSTR4 expression via qPCR or Western blot. Use a positive control agonist with known potency and efficacy.
Suboptimal forskolin concentration: The forskolin concentration may be too high, making it difficult to observe inhibition.	Perform a forskolin dose-response curve and use a concentration that yields approximately 80% of the maximal response (EC80).
Agonist degradation or insolubility: The agonist may have degraded or precipitated out of solution.	Prepare fresh agonist solutions. Verify solubility in the assay buffer. For peptide agonists, use appropriate storage conditions.
Incorrect assay buffer: Buffer components may interfere with the assay.	Ensure the buffer composition is optimized for the specific cAMP assay kit being used.

[³⁵S]GTPyS Binding Assays

Problem: High non-specific binding of [³⁵S]GTPyS.

Possible Cause	Solution
Suboptimal assay buffer: Incorrect concentrations of Mg ²⁺ , GDP, or NaCl can increase non-specific binding.	Optimize the concentrations of these components. Typically, higher GDP concentrations can reduce basal [³⁵ S]GTPyS binding.
Poor membrane quality: Damaged or improperly prepared cell membranes can expose non-receptor binding sites.	Ensure proper membrane preparation techniques and store membranes at -80°C in appropriate buffers.
Filter binding issues: The radioligand may be binding to the filter plates.	Pre-soak filter plates in wash buffer or a solution of bovine serum albumin (BSA) to block non-specific sites.

Problem: Low signal-to-noise ratio.

Possible Cause	Solution
Low receptor-G protein coupling efficiency: The cell line may have low levels of Gi/o proteins.	Consider using a cell line with higher endogenous Gi/o expression or co-transfect with G protein subunits.
Insufficient agonist stimulation time: The incubation time may not be sufficient to reach equilibrium.	Perform a time-course experiment to determine the optimal incubation time for agonist stimulation.
High basal activity: High agonist-independent G protein activation can mask the agonist-induced signal.	Optimize the GDP concentration to reduce basal signaling without significantly affecting the agonist response.

β-Arrestin Recruitment Assays

Problem: No or weak β-arrestin recruitment signal.

Possible Cause	Solution
SSTR4 does not recruit β-arrestin efficiently: Some GPCRs are poor recruiters of β-arrestin.	Confirm that SSTR4 is expected to recruit β-arrestin in your cell system. Use a positive control GPCR known to robustly recruit β-arrestin.
Biased agonism: The SSTR4 agonist may be G protein-biased and a poor inducer of β-arrestin recruitment.	Test a different SSTR4 agonist with a known β-arrestin recruitment profile.
Suboptimal assay conditions: Cell density, reagent concentrations, and incubation times can affect the signal.	Optimize these parameters according to the assay manufacturer's instructions.
Steric hindrance from tags: If using tagged proteins (e.g., in BRET or FRET assays), the tags may interfere with the interaction.	Test different tag positions or use an assay that does not require receptor tagging.

Quantitative Data

Table 1: Potency (EC₅₀) of Selected SSTR4 Agonists in Functional Assays

Agonist	Assay Type	Cell Line	EC ₅₀ (nM)	Reference
Consomatin Fj1	β-arrestin recruitment	HEK293	22	
Consomatin Fj1	G protein dissociation	HEK293	6.0	
J-2156	[³⁵ S]GTPγS binding	CHO-K1 (human SSTR4)	92	
Compound 1 (pyrrolo-pyrimidine)	[³⁵ S]GTPγS binding	CHO (sst4-expressing)	37	
Compound 2 (pyrrolo-pyrimidine)	[³⁵ S]GTPγS binding	CHO (sst4-expressing)	66	
Compound 3 (pyrrolo-pyrimidine)	[³⁵ S]GTPγS binding	CHO (sst4-expressing)	149	
Compound 4 (pyrrolo-pyrimidine)	[³⁵ S]GTPγS binding	CHO (sst4-expressing)	70	
Somatostatin-28	LANCE® cAMP assay	CHO-K1 (human SSTR4)	0.44	
L-803,087	LANCE® cAMP assay	CHO-K1 (human SSTR4)	0.41	

Table 2: Binding Affinity (K_i) and Selectivity of SSTR4 Agonists

Agonist	Receptor Subtype	Ki (nM)	Selectivity (fold vs SSTR4)	Reference
J-2156	SSTR4	-	-	
SSTR1	-	~360		
SSTR5	-	~390		
TT-232	SSTR4	-	-	
SSTR1	-	6.5		

Note: Ki values are often determined through competitive binding assays and can vary depending on the radioligand and experimental conditions used.

Experimental Protocols

Protocol 1: cAMP Inhibition Assay

This protocol outlines a general procedure for measuring the inhibition of forskolin-stimulated cAMP production by an SSTR4 agonist.

- **Cell Culture:** Culture CHO-K1 cells stably expressing human SSTR4 in Ham's F-12 medium supplemented with 10% FBS.
- **Cell Plating:** Seed the cells into a 384-well white opaque plate at a density of 2,500 cells/well and incubate overnight.
- **Compound Preparation:** Prepare serial dilutions of the SSTR4 agonist in stimulation buffer (e.g., HBSS, 5 mM HEPES, 0.1% BSA, 0.5 mM IBMX, pH 7.4).
- **Agonist Stimulation:** Add the agonist dilutions to the cells.
- **Forskolin Stimulation:** Add forskolin to a final concentration that elicits approximately 80% of its maximal response (e.g., 10 μ M).
- **Incubation:** Incubate the plate for 30 minutes at room temperature.

- cAMP Detection: Lyse the cells and measure cAMP levels using a suitable detection kit (e.g., HTRF, LANCE, or luminescence-based) according to the manufacturer's instructions.
- Data Analysis: Plot the cAMP levels against the logarithm of the agonist concentration and fit the data to a four-parameter logistic equation to determine the EC₅₀ value.

Protocol 2: [³⁵S]GTPγS Binding Assay

This protocol provides a general workflow for a [³⁵S]GTPγS binding assay using cell membranes.

- Membrane Preparation: Prepare crude membrane fractions from cells expressing SSTR4.
- Assay Setup: In a 96-well plate, add assay buffer, unlabeled GTPγS (for non-specific binding), the SSTR4 agonist at various concentrations, and GDP.
- Membrane Addition: Add the membrane suspension to each well.
- Pre-incubation: Pre-incubate the plate to allow the agonist to bind to the receptors.
- Reaction Initiation: Add [³⁵S]GTPγS to initiate the binding reaction.
- Incubation: Incubate the plate with gentle shaking to allow for [³⁵S]GTPγS binding.
- Termination and Filtration: Stop the reaction by rapid filtration through a filter plate and wash the filters with ice-cold wash buffer.
- Detection: Dry the filter plate, add scintillation fluid, and count the radioactivity.
- Data Analysis: Subtract non-specific binding from all measurements. Plot the specific binding against the logarithm of the agonist concentration to determine EC₅₀ and E_{max} values.

Protocol 3: β-Arrestin Recruitment Assay

This protocol describes a general procedure for a cell-based β-arrestin recruitment assay, such as the PathHunter® assay.

- Cell Plating: Plate PathHunter® SSTR4 CHO-K1 β -Arrestin cells in the provided assay plate and incubate overnight.
- Compound Addition: Add serial dilutions of the SSTR4 agonist to the cells.
- Incubation: Incubate the plate for 90 minutes at 37°C.
- Detection: Add the detection reagent according to the manufacturer's protocol and incubate for 60 minutes at room temperature.
- Signal Measurement: Read the chemiluminescent signal using a plate reader.
- Data Analysis: Plot the signal against the logarithm of the agonist concentration and fit the data to determine the EC₅₀ value.

Visualizations

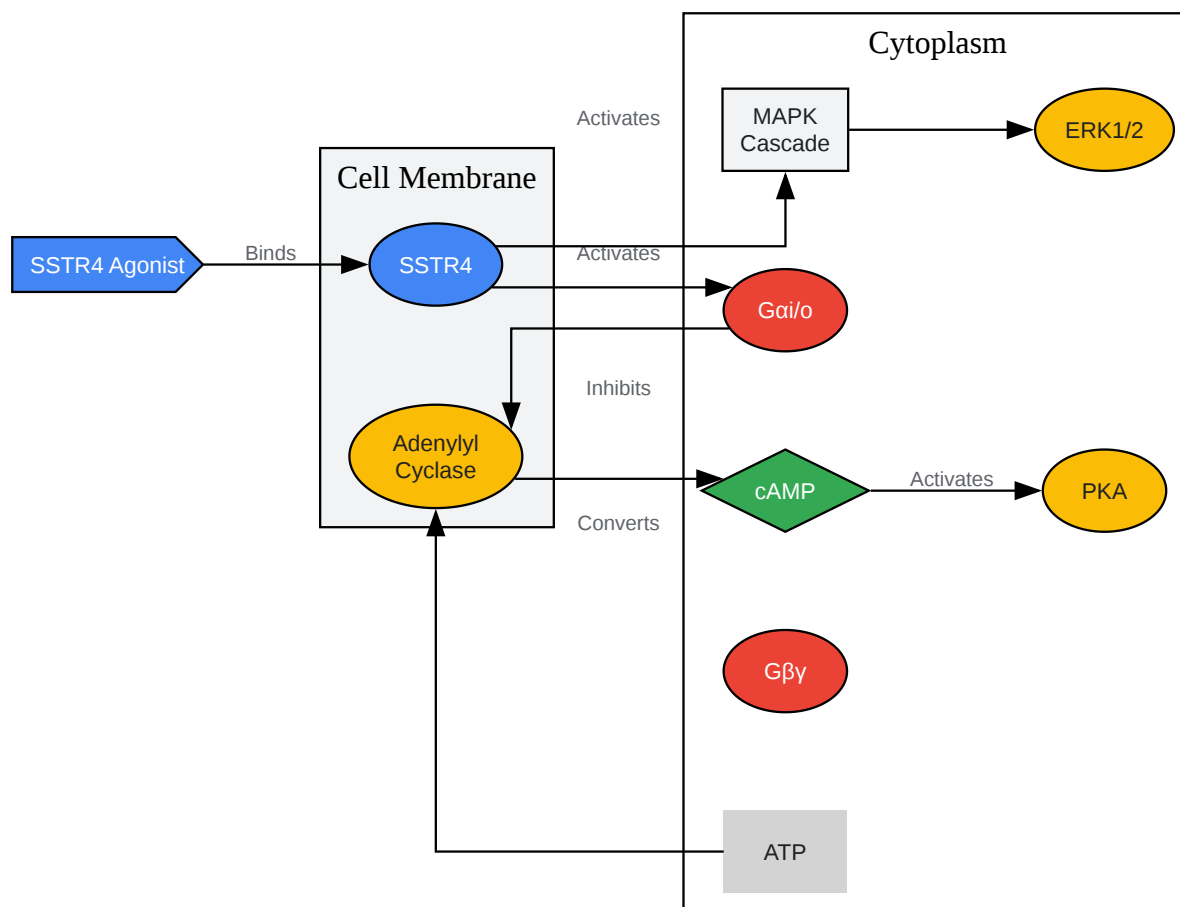

[Click to download full resolution via product page](#)

Caption: SSTR4 agonist signaling pathways.

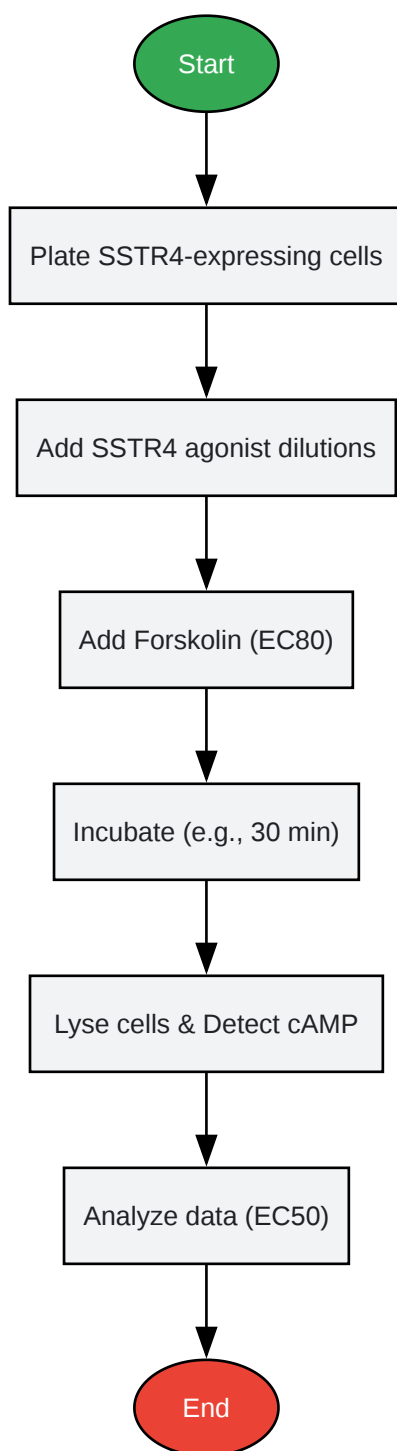

[Click to download full resolution via product page](#)

Caption: Workflow for a cAMP inhibition assay.

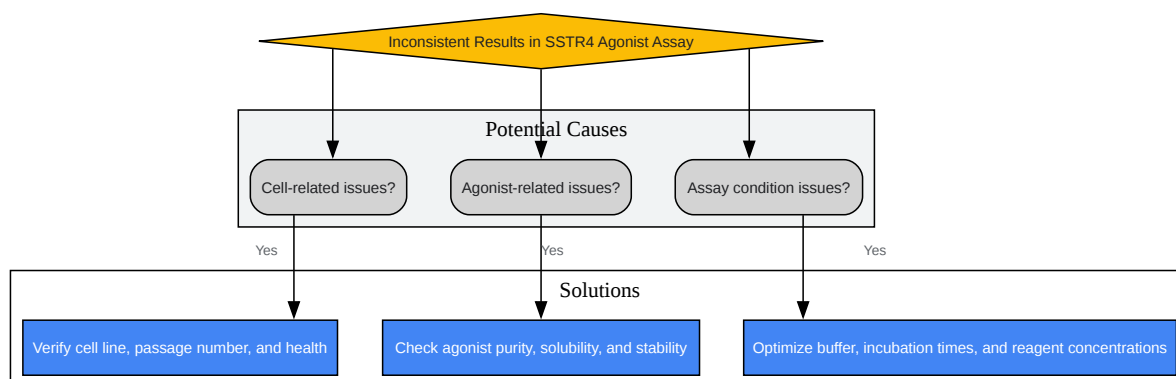

[Click to download full resolution via product page](#)

Caption: Troubleshooting logic for experimental variability.

Need Custom Synthesis?

BenchChem offers custom synthesis for rare earth carbides and specific isotopic labeling.

Email: info@benchchem.com or [Request Quote Online](#).

References

- 1. The role of G-proteins in the dimerisation of human somatostatin receptor types 2 and 5 - PubMed [pubmed.ncbi.nlm.nih.gov]
- 2. Functional coupling of SSTR4, a major hippocampal somatostatin receptor, to adenylate cyclase inhibition, arachidonate release and activation of the mitogen-activated protein kinase cascade - PubMed [pubmed.ncbi.nlm.nih.gov]
- 3. pubs.acs.org [pubs.acs.org]
- 4. biorxiv.org [biorxiv.org]
- To cite this document: BenchChem. [SSTR4 agonist 2 experimental variability and solutions]. BenchChem, [2026]. [Online PDF]. Available at:

[\[https://www.benchchem.com/product/b12414300/docs#sstr4-agonist-2-experimental-variability-and-solutions\]](https://www.benchchem.com/product/b12414300/docs#sstr4-agonist-2-experimental-variability-and-solutions)

Disclaimer & Data Validity:

The information provided in this document is for Research Use Only (RUO) and is strictly not intended for diagnostic or therapeutic procedures. While BenchChem strives to provide accurate protocols, we make no warranties, express or implied, regarding the fitness of this product for every specific experimental setup.

Technical Support: The protocols provided are for reference purposes. Unsure if this reagent suits your experiment?

Need Industrial/Bulk Grade? [Request Custom Synthesis Quote](#)

BenchChem

Our mission is to be the trusted global source of essential and advanced chemicals, empowering scientists and researchers to drive progress in science and industry.

Contact

Address: 3281 E Guasti Rd
Ontario, CA 91761, United States
Phone: (601) 213-4426
Email: info@benchchem.com

[Contact our Ph.D. Support Team for a compatibility check](#)