

Measuring 17(S)-HDHA Levels in Tissue Samples: Application Notes and Protocols

Author: BenchChem Technical Support Team. **Date:** April 2026

Compound of Interest

Compound Name: 17(S)-HDHA-d5

Cat. No.: B12413613

[Get Quote](#)

For Researchers, Scientists, and Drug Development Professionals

These application notes provide a comprehensive guide to the measurement of 17-hydroxy-4Z,7Z,10Z,13Z,15E,19Z-docosahexaenoic acid (17(S)-HDHA) in tissue samples. 17(S)-HDHA is a key bioactive lipid mediator derived from docosahexaenoic acid (DHA) and serves as a precursor to specialized pro-resolving mediators (SPMs), including D-series resolvins and protectins.^{[1][2][3]} Accurate quantification of 17(S)-HDHA is crucial for understanding its role in inflammatory processes and for the development of novel therapeutics targeting inflammation resolution.

Data Presentation

The following tables summarize quantitative data of 17(S)-HDHA levels reported in various mouse tissues. These values can serve as a reference for expected physiological concentrations.

Table 1: 17(S)-HDHA Levels in Tissues of Wildtype and Fat-1 Mice

Tissue	Genotype	17-HDHA Level (ng/g tissue)
Colon	Wildtype	~1.5
Colon	Fat-1	~2.5
Spleen	Wildtype	~1.0
Spleen	Fat-1	~1.2
Kidney	Wildtype	~1.8
Kidney	Fat-1	~2.5

Data extracted from a study on hydroxy lipid metabolites in mouse organs.[4] The fat-1 mouse model has an abundance of n-3 polyunsaturated fatty acids.[4]

Table 2: 17-HDHA Levels in Adipose Tissue of Mice on Different Diets

Adipose Tissue	Diet	17-HDHA Level (pg/mg tissue)
Gonadal	Normal Chow	~1.5
Gonadal	High-Fat (4 days)	~0.5
Gonadal	High-Fat (14 days)	~0.2

Data from a study on the local production of pro-resolving lipid mediators in obesity.

Signaling Pathway

The following diagram illustrates the biosynthetic pathway of 17(S)-HDHA from DHA and its subsequent conversion to D-series resolvins and protectin D1.

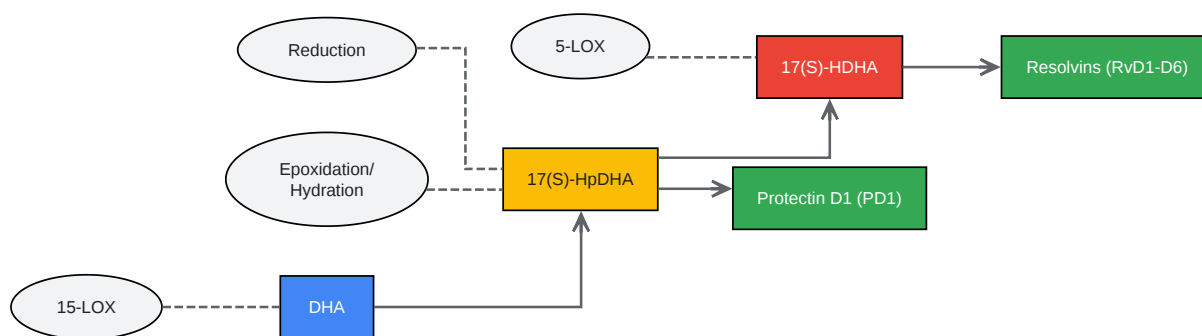

[Click to download full resolution via product page](#)

Caption: Biosynthesis of 17(S)-HDHA and its conversion to resolvins and protectins.

Experimental Protocols

This section details a generalized protocol for the quantification of 17(S)-HDHA in tissue samples using Liquid Chromatography-Tandem Mass Spectrometry (LC-MS/MS).

Experimental Workflow

The overall workflow for measuring 17(S)-HDHA in tissue is depicted below.

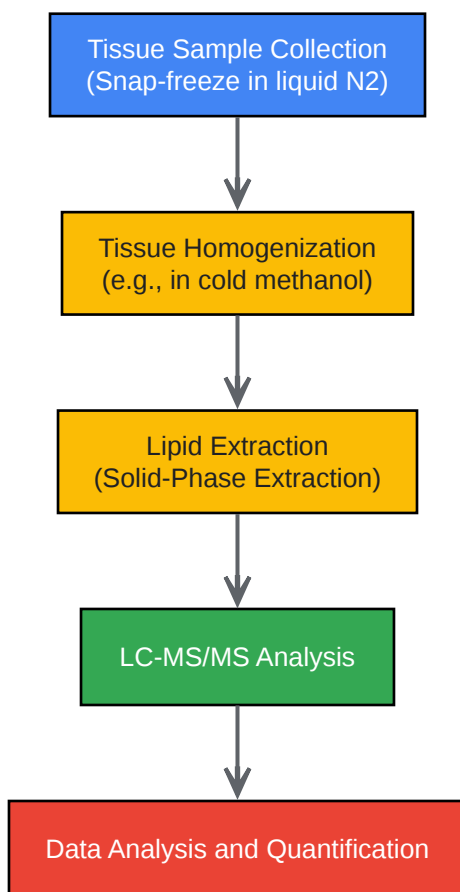

[Click to download full resolution via product page](#)

Caption: General workflow for 17(S)-HDHA measurement in tissue samples.

I. Materials and Reagents

- Solvents: Methanol (LC-MS grade), Acetonitrile (LC-MS grade), Water (LC-MS grade), Hexane (HPLC grade), Methyl Formate (HPLC grade), Acetic Acid (LC-MS grade)
- Internal Standard: Deuterated 17(S)-HDHA (e.g., 17(S)-HDHA-d8)
- Solid-Phase Extraction (SPE) Cartridges: C18 cartridges
- Other: Liquid nitrogen, homogenizer, centrifuge, evaporator (e.g., under nitrogen stream)

II. Sample Preparation

- Tissue Collection and Storage: Immediately snap-freeze tissue samples in liquid nitrogen upon collection and store at -80°C until analysis to prevent lipid oxidation.
- Tissue Homogenization:
 - Weigh the frozen tissue sample (typically 50-100 mg).
 - Homogenize the tissue in 2 mL of ice-cold methanol. This step is critical to deactivate enzymes that can degrade lipids.
- Internal Standard Spiking:
 - Add a known amount of deuterated internal standard (e.g., 1 ng of 17(S)-HDHA-d8) to the homogenate. The internal standard is essential for accurate quantification by correcting for sample loss during extraction and for matrix effects during LC-MS/MS analysis.

III. Lipid Extraction using Solid-Phase Extraction (SPE)

- Sample Centrifugation: Centrifuge the tissue homogenate at a low speed (e.g., 1500 x g) for 10 minutes at 4°C to pellet cellular debris.
- Acidification: Transfer the supernatant to a new tube and acidify to a pH of approximately 3.5 with a dilute acid (e.g., 0.1 M HCl).
- SPE Cartridge Conditioning:
 - Condition a C18 SPE cartridge by washing sequentially with 5 mL of methanol and 5 mL of water.
- Sample Loading: Load the acidified supernatant onto the conditioned C18 cartridge.
- Washing:
 - Wash the cartridge with 5 mL of water to remove polar impurities.
 - Wash the cartridge with 5 mL of hexane to remove non-polar, neutral lipids.
- Elution: Elute the desired lipid fraction containing 17(S)-HDHA with 8 mL of methyl formate.

- **Drying:** Evaporate the eluate to dryness under a gentle stream of nitrogen.
- **Reconstitution:** Reconstitute the dried lipid extract in a small volume (e.g., 100 μ L) of the initial LC mobile phase (e.g., a mixture of acetonitrile and water with 0.1% acetic acid).

IV. LC-MS/MS Analysis

- **Chromatographic Separation:**
 - **Column:** A C18 reversed-phase column is typically used for the separation of lipid mediators.
 - **Mobile Phase:** A binary gradient of acetonitrile and water, both containing a small amount of acetic acid (e.g., 0.1%), is commonly employed.
 - **Gradient:** A typical gradient would start with a lower concentration of acetonitrile, which is gradually increased to elute more hydrophobic compounds.
- **Mass Spectrometric Detection:**
 - **Ionization:** Electrospray ionization (ESI) in the negative ion mode is used for the detection of 17(S)-HDHA.
 - **Detection Mode:** Multiple Reaction Monitoring (MRM) is the preferred method for quantification due to its high selectivity and sensitivity.
 - **MRM Transitions:**
 - For 17(S)-HDHA, the precursor ion is $[M-H]^-$ at m/z 343.1.
 - Characteristic product ions for fragmentation include m/z 299.2 and 281.2.
 - For the deuterated internal standard, the corresponding mass transitions are monitored.

V. Data Analysis and Quantification

- **Calibration Curve:** Generate a calibration curve using a series of known concentrations of a 17(S)-HDHA standard, each spiked with the same amount of internal standard as the

samples.

- Quantification: Determine the concentration of 17(S)-HDHA in the tissue samples by comparing the peak area ratio of the analyte to the internal standard against the calibration curve. The final concentration is typically expressed as ng or pg of 17(S)-HDHA per mg or g of tissue.

Need Custom Synthesis?

BenchChem offers custom synthesis for rare earth carbides and specific isotopic labeling.

Email: info@benchchem.com or [Request Quote Online](#).

References

- [1. Pathway Markers for Pro-resolving Lipid Mediators in Maternal and Umbilical Cord Blood: A Secondary Analysis of the Mothers, Omega-3, and Mental Health Study - PMC \[pmc.ncbi.nlm.nih.gov\]](#)
- [2. Bioactive Lipid Mediators of Inflammation - The Medical Biochemistry Page \[themedicalbiochemistrypage.org\]](#)
- [3. The Development of a Specific and Sensitive LC-MS-Based Method for the Detection and Quantification of Hydroperoxy- and Hydroxydocosaehaenoic Acids as a Tool for Lipidomic Analysis - PMC \[pmc.ncbi.nlm.nih.gov\]](#)
- [4. Quantitative Profiling of Hydroxy Lipid Metabolites in Mouse Organs Reveals Distinct Lipidomic Profiles and Modifications Due to Elevated n-3 Fatty Acid Levels - PMC \[pmc.ncbi.nlm.nih.gov\]](#)
- To cite this document: BenchChem. [Measuring 17(S)-HDHA Levels in Tissue Samples: Application Notes and Protocols]. BenchChem, [2026]. [Online PDF]. Available at: [<https://www.benchchem.com/product/b12413613/docs#measuring-17-s-hdha-levels-in-tissue-samples-application-notes-and-protocols>]

Disclaimer & Data Validity:

The information provided in this document is for Research Use Only (RUO) and is strictly not intended for diagnostic or therapeutic procedures. While BenchChem strives to provide

accurate protocols, we make no warranties, express or implied, regarding the fitness of this product for every specific experimental setup.

Technical Support: The protocols provided are for reference purposes. Unsure if this reagent suits your experiment?

Need Industrial/Bulk Grade? [Request Custom Synthesis Quote](#)

BenchChem

Our mission is to be the trusted global source of essential and advanced chemicals, empowering scientists and researchers to drive progress in science and industry.

Contact

Address: 3281 E Guasti Rd

Ontario, CA 91761, United States

Phone: (601) 213-4426

Email: info@benchchem.com

[Contact our Ph.D. Support Team for a compatibility check](#)