

An In-depth Technical Guide to Lysophospholipid Signaling Pathways

Author: BenchChem Technical Support Team. **Date:** April 2026

Compound of Interest

Compound Name: 22:0 Lyso PC-13C6

Cat. No.: B12413150

[Get Quote](#)

For Researchers, Scientists, and Drug Development Professionals

This technical guide provides a comprehensive overview of the core signaling pathways mediated by lysophospholipids, with a primary focus on the well-characterized mediators, lysophosphatidic acid (LPA) and sphingosine-1-phosphate (S1P). This document details their synthesis, cognate G protein-coupled receptors (GPCRs), and the intricate downstream signaling cascades that regulate a multitude of physiological and pathophysiological processes. Furthermore, this guide includes a summary of other emerging bioactive lysophospholipids, detailed experimental protocols for studying these pathways, and quantitative data on receptor engagement and activation.

Introduction to Lysophospholipid Signaling

Lysophospholipids (LPLs) are a class of signaling molecules derived from membrane phospholipids through the action of phospholipases.[1][2] These bioactive lipids, once considered mere metabolic intermediates, are now recognized as critical extracellular mediators that orchestrate a wide array of cellular responses, including cell proliferation, migration, survival, and differentiation.[3][4] Dysregulation of LPL signaling has been implicated

in numerous diseases, including cancer, fibrosis, cardiovascular diseases, and autoimmune disorders, making the components of these pathways attractive therapeutic targets.[\[5\]](#)[\[6\]](#)[\[7\]](#)

The most extensively studied LPLs are lysophosphatidic acid (LPA) and sphingosine-1-phosphate (S1P).[\[2\]](#)[\[3\]](#) They exert their effects by binding to and activating specific families of GPCRs on the cell surface.[\[8\]](#)[\[9\]](#)[\[10\]](#) This guide will delve into the core aspects of LPA and S1P signaling, and also touch upon the emerging roles of other LPLs like lysophosphatidylserine (LysoPS) and lysophosphatidylinositol (LPI).

Lysophosphatidic Acid (LPA) Signaling

LPA is a simple phospholipid consisting of a glycerol backbone, a single acyl chain, and a phosphate head group.[\[10\]](#) It is produced by multiple enzymatic pathways, with a major route involving the hydrolysis of lysophosphatidylcholine (LPC) by the enzyme autotaxin (ATX).[\[10\]](#) LPA signals through at least six cognate GPCRs, designated LPA₁ to LPA₆, which belong to two distinct families: the endothelial differentiation gene (EDG) family (LPA₁₋₃) and the P2Y purinergic receptor family (LPA₄₋₆).[\[9\]](#)[\[11\]](#)

LPA Receptors and G-Protein Coupling

LPA receptors couple to one or more of the four main families of heterotrimeric G proteins ($G\alpha_i/o$, $G\alpha_o/11$, $G\alpha_{12/13}$, and $G\alpha_s$) to initiate downstream signaling cascades.[\[10\]](#)[\[12\]](#) The specific G protein coupling determines the subsequent cellular response.[\[10\]](#)[\[13\]](#)

Receptor	G-Protein Coupling
LPA ₁	$G\alpha_i/o$, $G\alpha_o/11$, $G\alpha_{12/13}$
LPA ₂	$G\alpha_i/o$, $G\alpha_o/11$, $G\alpha_{12/13}$
LPA ₃	$G\alpha_i/o$, $G\alpha_o/11$
LPA ₄	$G\alpha_s$, $G\alpha_{12/13}$
LPA ₅	$G\alpha_o/11$, $G\alpha_{12/13}$
LPA ₆	$G\alpha_{12/13}$

Table 1: G-protein coupling of human LPA receptors.

Downstream Signaling Pathways of LPA Receptors

Activation of LPA receptors triggers a complex network of intracellular signaling pathways:

- $G\alpha_{i/o}$ Pathway: This pathway leads to the inhibition of adenylyl cyclase, resulting in decreased cyclic AMP (cAMP) levels. It can also activate the phosphatidylinositol 3-kinase (PI3K)-Akt pathway, promoting cell survival, and the Ras-MAPK (ERK1/2) pathway, which is involved in cell proliferation and differentiation.[\[10\]](#)[\[13\]](#)
- $G\alpha_{o/11}$ Pathway: This pathway activates phospholipase C (PLC), which hydrolyzes phosphatidylinositol 4,5-bisphosphate (PIP₂) into inositol 1,4,5-trisphosphate (IP₃) and diacylglycerol (DAG). IP₃ triggers the release of intracellular calcium (Ca²⁺), while DAG activates protein kinase C (PKC).[\[10\]](#)[\[13\]](#)
- $G\alpha_{12/13}$ Pathway: This pathway activates the small GTPase RhoA, leading to the activation of Rho-associated kinase (ROCK). This cascade is crucial for cytoskeletal rearrangements, stress fiber formation, and cell migration.[\[10\]](#)[\[13\]](#)
- $G\alpha_s$ Pathway: Primarily associated with LPA₄, this pathway stimulates adenylyl cyclase, leading to an increase in intracellular cAMP levels.[\[13\]](#)

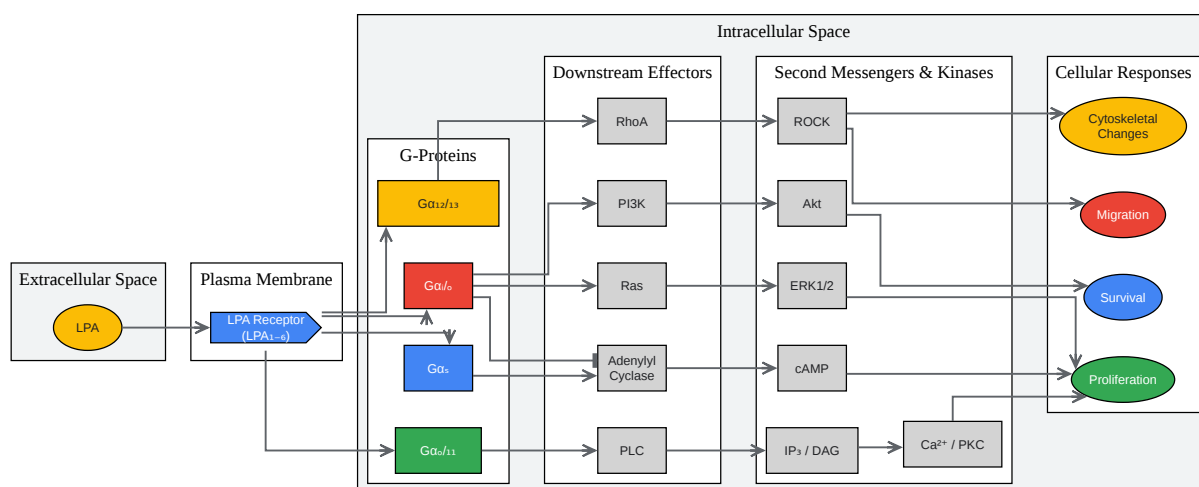

[Click to download full resolution via product page](#)

Figure 1. Simplified LPA signaling pathways.

Sphingosine-1-Phosphate (S1P) Signaling

S1P is a bioactive sphingolipid metabolite formed by the phosphorylation of sphingosine, a reaction catalyzed by sphingosine kinases (SphKs).[3][5] S1P plays a crucial role in the regulation of the immune, cardiovascular, and central nervous systems.[14] It signals through a family of five specific GPCRs, termed S1P₁ to S1P₅.[15]

S1P Receptors and G-Protein Coupling

Similar to LPA receptors, S1P receptors exhibit differential coupling to heterotrimeric G proteins, which dictates the downstream cellular effects.[16][17]

Receptor	G-Protein Coupling
S1P ₁	G $\alpha_{i/o}$
S1P ₂	G $\alpha_{i/o}$, G $\alpha_{o/11}$, G $\alpha_{12/13}$
S1P ₃	G $\alpha_{i/o}$, G $\alpha_{o/11}$, G $\alpha_{12/13}$
S1P ₄	G $\alpha_{i/o}$, G $\alpha_{12/13}$
S1P ₅	G $\alpha_{i/o}$, G $\alpha_{12/13}$

Table 2: G-protein coupling of human S1P receptors.[18]

Downstream Signaling Pathways of S1P Receptors

The activation of S1P receptors initiates a variety of signaling cascades:

- **G $\alpha_{i/o}$ Pathway:** S1P₁ exclusively couples to G $\alpha_{i/o}$, leading to the activation of the PI3K-Akt and Ras-MAPK pathways, as well as Rac activation, which is important for cell migration and survival.[16][18] It also inhibits adenylyl cyclase.
- **G $\alpha_{o/11}$ Pathway:** S1P₂ and S1P₃ coupling to G $\alpha_{o/11}$ activates PLC, resulting in increased intracellular Ca²⁺ and PKC activation.[18]
- **G $\alpha_{12/13}$ Pathway:** S1P₂ and S1P₃ also couple to G $\alpha_{12/13}$, leading to RhoA activation and subsequent cytoskeletal changes.[18][19]

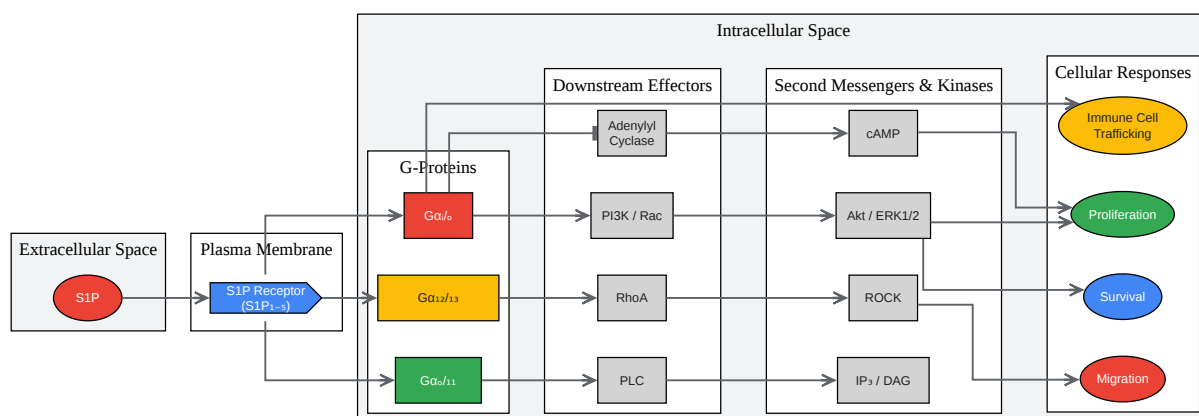

[Click to download full resolution via product page](#)

Figure 2. Simplified S1P signaling pathways.

Other Bioactive Lysophospholipids

While LPA and S1P are the most studied, other LPLs are emerging as important signaling molecules.

- Lysophosphatidylserine (LysoPS): LysoPS signals through at least three G protein-coupled receptors: GPR34, P2Y10, and GPR174.[2][20] It is involved in immune regulation, including mast cell degranulation and modulation of T-cell function.[20][21]
- Lysophosphatidylinositol (LPI): LPI is an endogenous ligand for the G protein-coupled receptor GPR55.[1][22] The LPI-GPR55 signaling axis has been implicated in various physiological processes, including inflammation, pain perception, and metabolism.[1]

Quantitative Data on Receptor Engagement

The affinity of lysophospholipids for their receptors (Kd) and the concentration required to elicit a half-maximal response (EC₅₀) are critical parameters for understanding their biological activity and for drug development.

Ligand	Receptor	Kd (nM)	EC ₅₀ (nM)
18:1 LPA	LPA ₁	2.08 ± 1.32	~200
16:0 LPA	LPA ₁	1.69 ± 0.1	~400
S1P	S1P ₁	-	1.9 - 13.8
Fingolimod-P	S1P ₁	-	-
Ozanimod	S1P ₁	-	1.03
Siponimod	S1P ₁	-	0.39

Table 3: Selected binding affinities (Kd) and activation potencies (EC₅₀) of various ligands for LPA and S1P receptors. Note: Data is compiled from multiple sources and experimental conditions may vary.[\[1\]](#)[\[10\]](#)[\[23\]](#)[\[24\]](#)

Experimental Protocols

Studying lysophospholipid signaling pathways involves a variety of in vitro and cell-based assays. Below are detailed methodologies for key experiments.

Radioligand Binding Assay

This assay is used to determine the binding affinity (Kd) and receptor density (Bmax) of a radiolabeled ligand to its receptor.

Protocol:

- **Membrane Preparation:** Culture cells expressing the receptor of interest and harvest them. Homogenize the cells in a cold lysis buffer and centrifuge to pellet the membranes. Resuspend the membrane pellet in a binding buffer.

- **Binding Reaction:** In a 96-well plate, add the cell membrane preparation, a fixed concentration of radiolabeled ligand (e.g., [³H]LPA or [³²P]S1P), and increasing concentrations of a competing unlabeled ligand.
- **Incubation:** Incubate the plate at a specific temperature for a time sufficient to reach equilibrium.
- **Filtration:** Rapidly filter the contents of each well through a glass fiber filter to separate bound from free radioligand.
- **Washing:** Wash the filters with ice-cold wash buffer to remove non-specifically bound radioligand.
- **Scintillation Counting:** Place the filters in scintillation vials with scintillation fluid and measure the radioactivity using a scintillation counter.
- **Data Analysis:** Plot the amount of bound radioligand as a function of the unlabeled ligand concentration. Use non-linear regression to determine the IC₅₀, from which the K_i (and subsequently K_d) can be calculated.

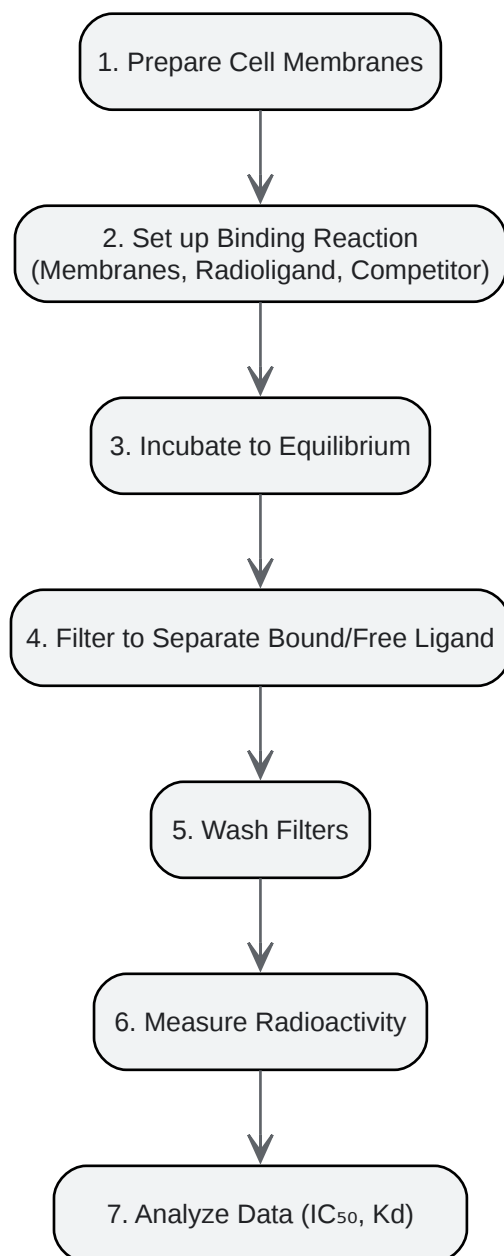

[Click to download full resolution via product page](#)

Figure 3. Workflow for a radioligand binding assay.

Calcium Mobilization Assay

This assay measures the increase in intracellular calcium concentration following the activation of G_{o/11}-coupled receptors.

Protocol:

- **Cell Culture:** Seed cells expressing the receptor of interest in a 96-well black-walled, clear-bottom plate.
- **Dye Loading:** Load the cells with a calcium-sensitive fluorescent dye (e.g., Fluo-4 AM) in a buffer, often containing probenecid to prevent dye extrusion. Incubate to allow for de-esterification of the dye.
- **Ligand Addition:** Place the plate in a fluorescence plate reader. After establishing a baseline fluorescence reading, add the agonist at various concentrations.
- **Fluorescence Measurement:** Measure the change in fluorescence intensity over time. The peak fluorescence intensity corresponds to the maximal calcium release.
- **Data Analysis:** Plot the peak fluorescence intensity against the agonist concentration and fit the data to a sigmoidal dose-response curve to determine the EC_{50} .

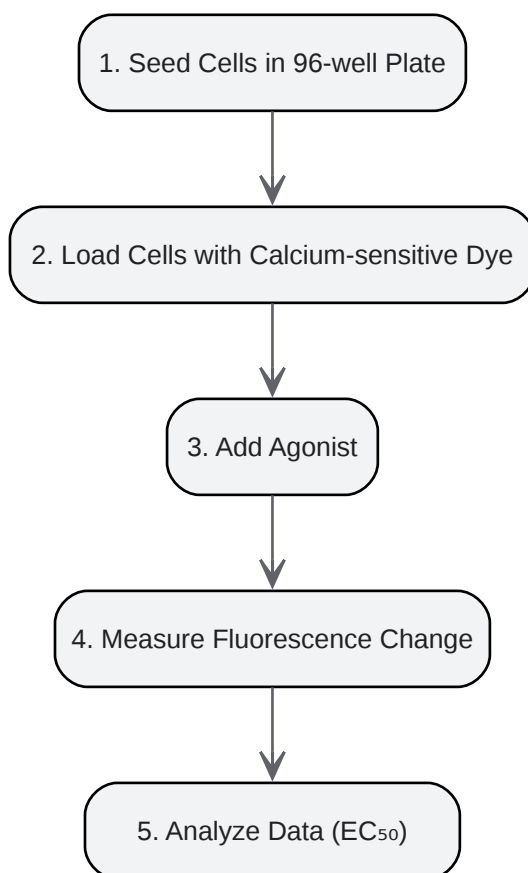

[Click to download full resolution via product page](#)

Figure 4. Workflow for a calcium mobilization assay.

ERK1/2 Phosphorylation Assay (Western Blot)

This assay detects the activation of the MAPK/ERK pathway.

Protocol:

- **Cell Treatment:** Culture cells to sub-confluency and serum-starve them to reduce basal ERK1/2 phosphorylation. Treat the cells with the agonist for various time points.
- **Cell Lysis:** Lyse the cells in a radioimmunoprecipitation assay (RIPA) buffer containing protease and phosphatase inhibitors.
- **Protein Quantification:** Determine the protein concentration of the lysates.
- **SDS-PAGE and Western Blotting:** Separate the proteins by SDS-polyacrylamide gel electrophoresis and transfer them to a PVDF membrane.
- **Immunoblotting:** Block the membrane and then incubate with a primary antibody specific for phosphorylated ERK1/2 (p-ERK1/2). Subsequently, incubate with a horseradish peroxidase (HRP)-conjugated secondary antibody.
- **Detection:** Detect the signal using an enhanced chemiluminescence (ECL) substrate.
- **Stripping and Re-probing:** Strip the membrane and re-probe with an antibody for total ERK1/2 as a loading control.
- **Densitometry:** Quantify the band intensities and normalize the p-ERK1/2 signal to the total ERK1/2 signal.

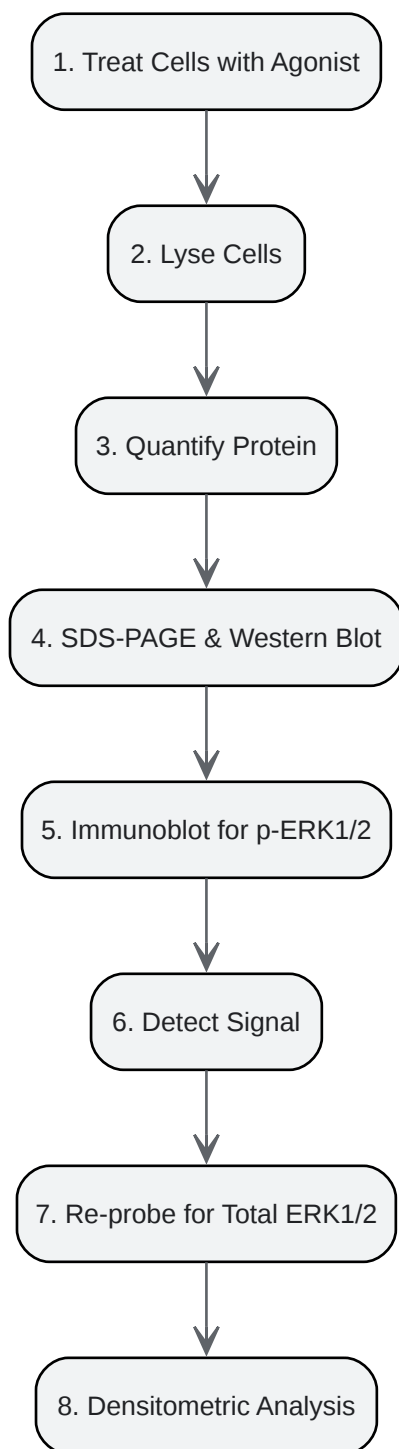

[Click to download full resolution via product page](#)

Figure 5. Workflow for an ERK1/2 phosphorylation assay.

Conclusion

The study of lysophospholipid signaling pathways has unveiled a complex and crucial layer of cellular regulation. The diverse actions of LPA, S1P, and other emerging LPLs, mediated by their specific GPCRs, are integral to numerous physiological processes and are increasingly recognized for their roles in disease. The continued development of selective agonists and antagonists for these receptors holds significant promise for novel therapeutic interventions. This guide provides a foundational understanding of these intricate signaling networks and the experimental approaches to investigate them, serving as a valuable resource for researchers and drug development professionals in this dynamic field.

Need Custom Synthesis?

BenchChem offers custom synthesis for rare earth carbides and specific isotopic labeling.

Email: info@benchchem.com or [Request Quote Online](#).

References

- [1. Lysophosphatidylinositol Signalling and Metabolic Diseases - PMC \[pmc.ncbi.nlm.nih.gov\]](#)
- [2. The Lysophosphatidylserines-An Emerging Class of Signalling Lysophospholipids - PubMed \[pubmed.ncbi.nlm.nih.gov\]](#)
- [3. SPHINGOSINE-1-PHOSPHATE SIGNALING AND ITS ROLE IN DISEASE - PMC \[pmc.ncbi.nlm.nih.gov\]](#)
- [4. Lysophosphatidic Acid Signalling in Nervous System Development and Function - PMC \[pmc.ncbi.nlm.nih.gov\]](#)
- [5. Sphingosine-1-phosphate signaling and its role in disease - PubMed \[pubmed.ncbi.nlm.nih.gov\]](#)
- [6. Roles of lysophosphatidic acid in cardiovascular physiology and disease - PubMed \[pubmed.ncbi.nlm.nih.gov\]](#)
- [7. Lysophosphatidic Acid Receptor Antagonists and Cancer: The Current Trends, Clinical Implications, and Trials - PMC \[pmc.ncbi.nlm.nih.gov\]](#)
- [8. researchgate.net \[researchgate.net\]](#)
- [9. Lysophosphatidic acid signalling in development - PMC \[pmc.ncbi.nlm.nih.gov\]](#)
- [10. LPA receptor signaling: pharmacology, physiology, and pathophysiology - PMC \[pmc.ncbi.nlm.nih.gov\]](#)

- [11. Lysophosphatidic acid receptor - Wikipedia \[en.wikipedia.org\]](#)
- [12. G-Protein-Coupled Lysophosphatidic Acid Receptors and Their Regulation of AKT Signaling - PMC \[pmc.ncbi.nlm.nih.gov\]](#)
- [13. researchgate.net \[researchgate.net\]](#)
- [14. Emerging biology of sphingosine-1-phosphate: its role in pathogenesis and therapy - PMC \[pmc.ncbi.nlm.nih.gov\]](#)
- [15. Sphingosine-1-phosphate receptor - Wikipedia \[en.wikipedia.org\]](#)
- [16. Sphingosine-1-Phosphate-Specific G Protein-Coupled Receptors as Novel Therapeutic Targets for Atherosclerosis - PMC \[pmc.ncbi.nlm.nih.gov\]](#)
- [17. researchgate.net \[researchgate.net\]](#)
- [18. researchgate.net \[researchgate.net\]](#)
- [19. Sphingosine 1-phosphate signalling - PMC \[pmc.ncbi.nlm.nih.gov\]](#)
- [20. Lysophosphatidylserine - Wikipedia \[en.wikipedia.org\]](#)
- [21. The Lysophosphatidylserines – an Emerging Class of Signalling Lysophospholipid - PMC \[pmc.ncbi.nlm.nih.gov\]](#)
- [22. The actions and metabolism of lysophosphatidylinositol, an endogenous agonist for GPR55 - PubMed \[pubmed.ncbi.nlm.nih.gov\]](#)
- [23. researchgate.net \[researchgate.net\]](#)
- [24. researchgate.net \[researchgate.net\]](#)
- [To cite this document: BenchChem. \[An In-depth Technical Guide to Lysophospholipid Signaling Pathways\]. BenchChem, \[2026\]. \[Online PDF\]. Available at: \[https://www.benchchem.com/product/b12413150/docs#an-in-depth-technical-guide-to-lysophospholipid-signaling-pathways\]](#)

Disclaimer & Data Validity:

The information provided in this document is for Research Use Only (RUO) and is strictly not intended for diagnostic or therapeutic procedures. While BenchChem strives to provide accurate protocols, we make no warranties, express or implied, regarding the fitness of this product for every specific experimental setup.

Technical Support: The protocols provided are for reference purposes. Unsure if this reagent suits your experiment?

Need Industrial/Bulk Grade? [Request Custom Synthesis Quote](#)

BenchChem

Our mission is to be the trusted global source of essential and advanced chemicals, empowering scientists and researchers to drive progress in science and industry.

Contact

Address: 3281 E Guasti Rd
Ontario, CA 91761, United States
Phone: (601) 213-4426
Email: info@benchchem.com

[Contact our Ph.D. Support Team for a compatibility check](#)