

# An In-Depth Technical Guide to Metabolic Flux Analysis Using $^{13}\text{C}$ Tracers

**Author:** BenchChem Technical Support Team. **Date:** December 2025

## Compound of Interest

Compound Name: *D-Glucono-1,5-lactone-1- $^{13}\text{C}$*

Cat. No.: B12412635

[Get Quote](#)

For Researchers, Scientists, and Drug Development Professionals

This guide provides a comprehensive technical overview of  $^{13}\text{C}$  Metabolic Flux Analysis ( $^{13}\text{C}$ -MFA), a powerful technique for quantifying intracellular metabolic fluxes. It is designed to equip researchers, scientists, and drug development professionals with the foundational knowledge and practical insights required to design, implement, and interpret  $^{13}\text{C}$ -MFA experiments.

## Introduction to Metabolic Flux Analysis (MFA)

Metabolic Flux Analysis (MFA) is a critical tool for understanding the intricate network of biochemical reactions that constitute cellular metabolism. Unlike metabolomics, which provides a snapshot of metabolite concentrations, MFA quantifies the rates of these reactions, offering a dynamic view of cellular physiology.[1][2] By tracing the path of stable isotopes, such as Carbon-13 ( $^{13}\text{C}$ ), through metabolic pathways, researchers can elucidate the contributions of different pathways to cellular bioenergetics and biosynthesis.[1][3] This quantitative understanding is invaluable for identifying metabolic bottlenecks, characterizing disease states, and discovering novel drug targets.[4]

$^{13}\text{C}$ -MFA has become the gold standard for flux quantification due to its ability to resolve fluxes in complex networks, including parallel pathways and cycles, which is not possible with stoichiometric models alone. The core principle involves introducing a  $^{13}\text{C}$ -labeled substrate (a "tracer") into a biological system and measuring the resulting isotopic labeling patterns in downstream metabolites. These labeling patterns, along with measured extracellular fluxes

(e.g., nutrient uptake and product secretion rates), are then used to computationally estimate the intracellular fluxes that best explain the observed data.

## The Core Principles of $^{13}\text{C}$ -MFA

The fundamental concept of  $^{13}\text{C}$ -MFA is that the distribution of  $^{13}\text{C}$  isotopes in metabolic intermediates is a direct consequence of the relative activities of the metabolic pathways through which they are synthesized. Different flux distributions will result in distinct labeling patterns.

Key Concepts:

- **Isotopic Steady State:** For stationary  $^{13}\text{C}$ -MFA, it is crucial that the system reaches an isotopic steady state, where the isotopic labeling of intracellular metabolites remains constant over time. This indicates that the labeling from the  $^{13}\text{C}$  tracer has fully propagated throughout the metabolic network.
- **Metabolic Steady State:** This assumes that the concentrations of intracellular metabolites and the metabolic fluxes are constant over the course of the experiment.
- **Isotopomers and Mass Isotopomer Distributions (MIDs):** Isotopomers are molecules that differ only in their isotopic composition. Mass spectrometry is used to measure the mass isotopomer distribution (MID) of a metabolite, which is the relative abundance of each of its isotopomers. This MID is a key piece of experimental data used for flux calculations.

There are two main approaches to  $^{13}\text{C}$ -MFA:

- **Stationary  $^{13}\text{C}$ -MFA:** This is the most common approach and assumes both metabolic and isotopic steady state. It provides a time-averaged view of the metabolic fluxes.
- **Isotopically Non-stationary  $^{13}\text{C}$ -MFA (INST-MFA):** This method analyzes the transient changes in isotopic labeling over time before reaching isotopic steady state. INST-MFA can provide additional information about flux dynamics and is particularly useful for systems where achieving isotopic steady state is challenging.

# The $^{13}\text{C}$ -MFA Experimental and Computational Workflow

A successful  $^{13}\text{C}$ -MFA study involves a carefully planned and executed workflow that integrates experimental biology with computational analysis.

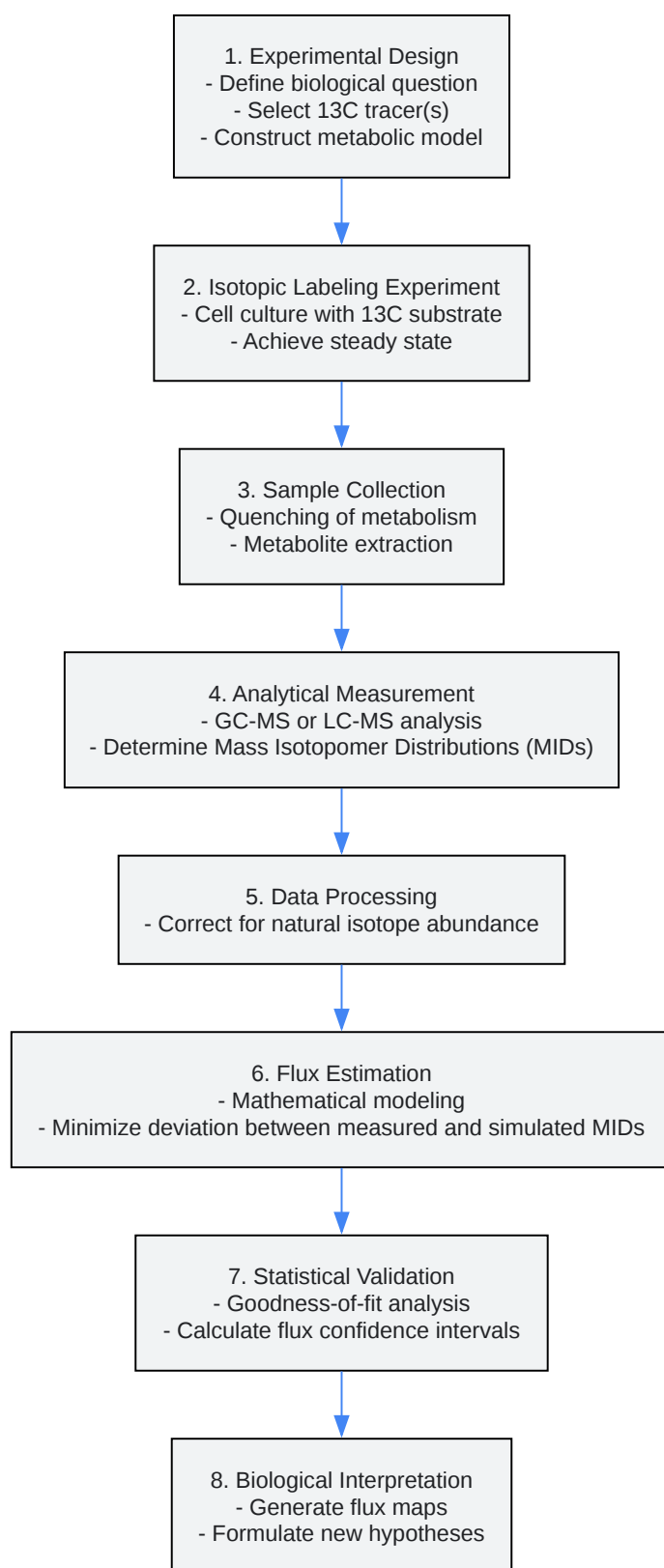

[Click to download full resolution via product page](#)

**Figure 1:** The general workflow of a <sup>13</sup>C Metabolic Flux Analysis experiment.

## Detailed Experimental Protocols

Precise and reproducible experimental execution is paramount for generating high-quality  $^{13}\text{C}$ -MFA data. The following sections provide detailed methodologies for the key experimental stages.

### Protocol 1: Cell Culture and Isotopic Labeling

This protocol provides a generalized procedure for adherent mammalian cells. It should be optimized for the specific cell line and experimental objectives.

Materials:

- Appropriate cell culture vessels (e.g., 6-well plates, 10-cm dishes)
- Standard, unlabeled cell culture medium
- Custom  $^{13}\text{C}$ -labeling medium (identical to standard medium but with the primary carbon source replaced by its  $^{13}\text{C}$ -labeled counterpart, e.g., [U- $^{13}\text{C}_6$ ]-glucose)
- Phosphate-buffered saline (PBS), pre-warmed to  $37^\circ\text{C}$

Procedure:

- **Cell Seeding and Growth:** Seed cells in the appropriate culture vessels and grow them in standard, unlabeled culture medium until they reach the desired confluence (typically 70-80% for log-phase analysis).
- **Medium Switch:** Aspirate the standard medium and wash the cells once with pre-warmed PBS. Immediately replace it with the custom  $^{13}\text{C}$ -labeling medium.
- **Isotopic Steady-State Incubation:** Place the cells back into the incubator for a duration sufficient to approach isotopic steady state. This time varies significantly between cell lines and is influenced by their proliferation rate and the pool sizes of the metabolites of interest. It is often determined empirically through a time-course experiment.

### Protocol 2: Metabolite Quenching and Extraction

Rapidly halting all enzymatic activity is critical to preserve the in vivo metabolic state of the cells.

Materials:

- Cold quenching solution (e.g., 60% methanol in water, pre-chilled to -40°C or colder)
- Cold extraction solvent (e.g., 80% methanol in water, pre-chilled to -80°C)
- Cell scraper
- Centrifuge capable of reaching >14,000 x g and maintaining 4°C

Procedure:

- Quenching: Quickly aspirate the <sup>13</sup>C-labeling medium from the culture vessel. Immediately add the cold quenching solution to the cells.
- Cell Lysis and Collection: Scrape the cells in the quenching solution and transfer the cell suspension to a pre-chilled microcentrifuge tube.
- Metabolite Extraction: Centrifuge the cell suspension at high speed (e.g., 14,000 x g) for 1-2 minutes at 4°C to pellet the cell debris.
- Supernatant Collection: Carefully transfer the supernatant, which contains the extracted metabolites, to a new pre-chilled tube.
- Solvent Evaporation: Evaporate the solvent from the metabolite extract, typically using a vacuum concentrator or a stream of nitrogen. The dried metabolite pellet can be stored at -80°C until analysis.

## Protocol 3: GC-MS Analysis of <sup>13</sup>C-Labeled Metabolites

Gas Chromatography-Mass Spectrometry (GC-MS) is a widely used analytical technique for <sup>13</sup>C-MFA. It requires derivatization of the metabolites to make them volatile.

Materials:

- Derivatization agent (e.g., N-tert-butyltrimethylsilyl-N-methyltrifluoroacetamide, MTBSTFA)
- GC-MS instrument equipped with an appropriate column (e.g., a non-polar column like DB-5ms)

Procedure:

- Derivatization: Reconstitute the dried metabolite pellet in a derivatization agent and incubate at an elevated temperature (e.g., 60-80°C) to complete the reaction.
- GC-MS Analysis: Inject the derivatized sample into the GC-MS. The gas chromatograph separates the derivatized metabolites, which are then ionized and fragmented in the mass spectrometer.
- Data Acquisition: The mass spectrometer detects the mass-to-charge ratio (m/z) of the resulting fragments. The data is collected in the form of mass spectra for each separated metabolite.
- Data Processing: The raw data is processed to determine the mass isotopomer distributions (MIDs) for each metabolite of interest. This involves correcting for the natural abundance of <sup>13</sup>C and other isotopes.

## Data Presentation: Summarizing Quantitative Flux Data

Clear and concise presentation of quantitative flux data is essential for interpretation and comparison across different experimental conditions. Flux maps are often normalized to a key uptake rate, such as glucose uptake, to facilitate comparison.

Table 1: Central Carbon Metabolism Fluxes in E. coli

Reaction	Flux (mmol/gDW/h) - Condition A	Flux (mmol/gDW/h) - Condition B
Glucose uptake	10.0 ± 0.5	8.0 ± 0.4
Glycolysis (PFK)	7.5 ± 0.6	6.2 ± 0.5
Pentose Phosphate Pathway (G6PDH)	2.5 ± 0.3	1.8 ± 0.2
TCA Cycle (CS)	4.0 ± 0.4	3.1 ± 0.3
Anaplerosis (PC)	1.0 ± 0.1	0.8 ± 0.1
Acetate secretion	2.0 ± 0.2	1.5 ± 0.1

Data are presented as mean ± standard deviation from triplicate experiments.

Table 2: Key Metabolic Fluxes in CHO Cells in a Bioreactor

Flux	Growth Phase (mmol/10 <sup>9</sup> cells/day)	Production Phase (mmol/10 <sup>9</sup> cells/day)
Glucose Uptake	120 ± 10	80 ± 8
Lactate Production	150 ± 12	20 ± 5
Glutamine Uptake	25 ± 3	15 ± 2
TCA Cycle (Citrate Synthase)	40 ± 4	55 ± 6
Pyruvate to Acetyl-CoA	35 ± 3	50 ± 5

Fluxes are normalized to the cell-specific glucose uptake rate.

Table 3: Metabolic Fluxes in Cancer Cells Under Normoxia and Hypoxia



Pathway	Relative Flux (Normoxia)	Relative Flux (Hypoxia)
Glycolysis	100	180 ± 15
Lactate Production	85 ± 7	160 ± 12
TCA Cycle	50 ± 5	20 ± 3
Pentose Phosphate Pathway	15 ± 2	25 ± 3
Reductive Carboxylation	5 ± 1	15 ± 2

Fluxes are normalized to the glycolytic flux under normoxia.

## Visualizing Metabolic and Signaling Pathways

Graphviz is a powerful tool for creating clear and informative diagrams of metabolic and signaling pathways. The following DOT scripts can be used to generate such diagrams.

### Glycolysis Pathway with <sup>13</sup>C Labeling

This diagram illustrates the flow of <sup>13</sup>C atoms from uniformly labeled glucose through the glycolytic pathway.

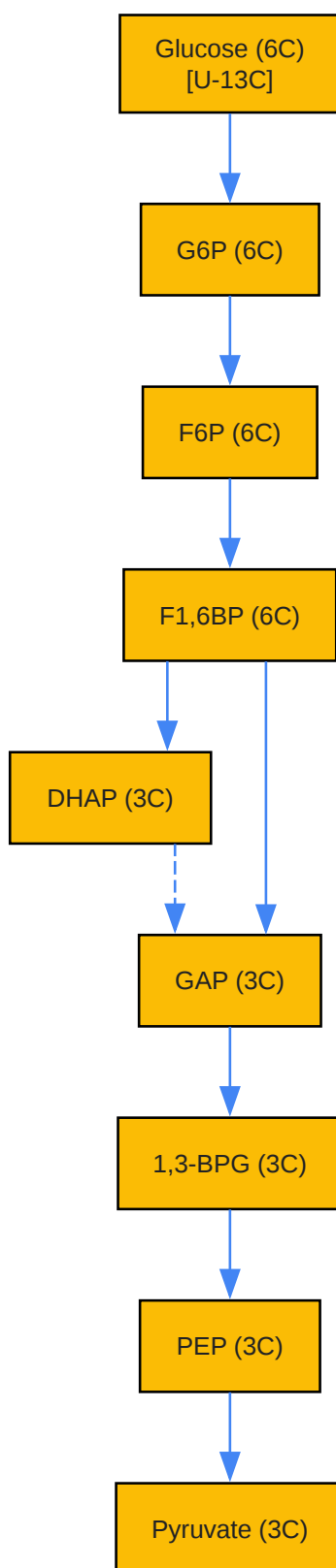

[Click to download full resolution via product page](#)

**Figure 2:** Flow of  $^{13}\text{C}$  label through the glycolytic pathway.

## PI3K/Akt/mTOR Signaling Pathway and its Influence on Metabolism

This diagram illustrates how the PI3K/Akt/mTOR signaling pathway, a key regulator of cell growth and proliferation, can influence central carbon metabolism. <sup>13</sup>C-MFA can be used to quantify the resulting changes in metabolic fluxes.

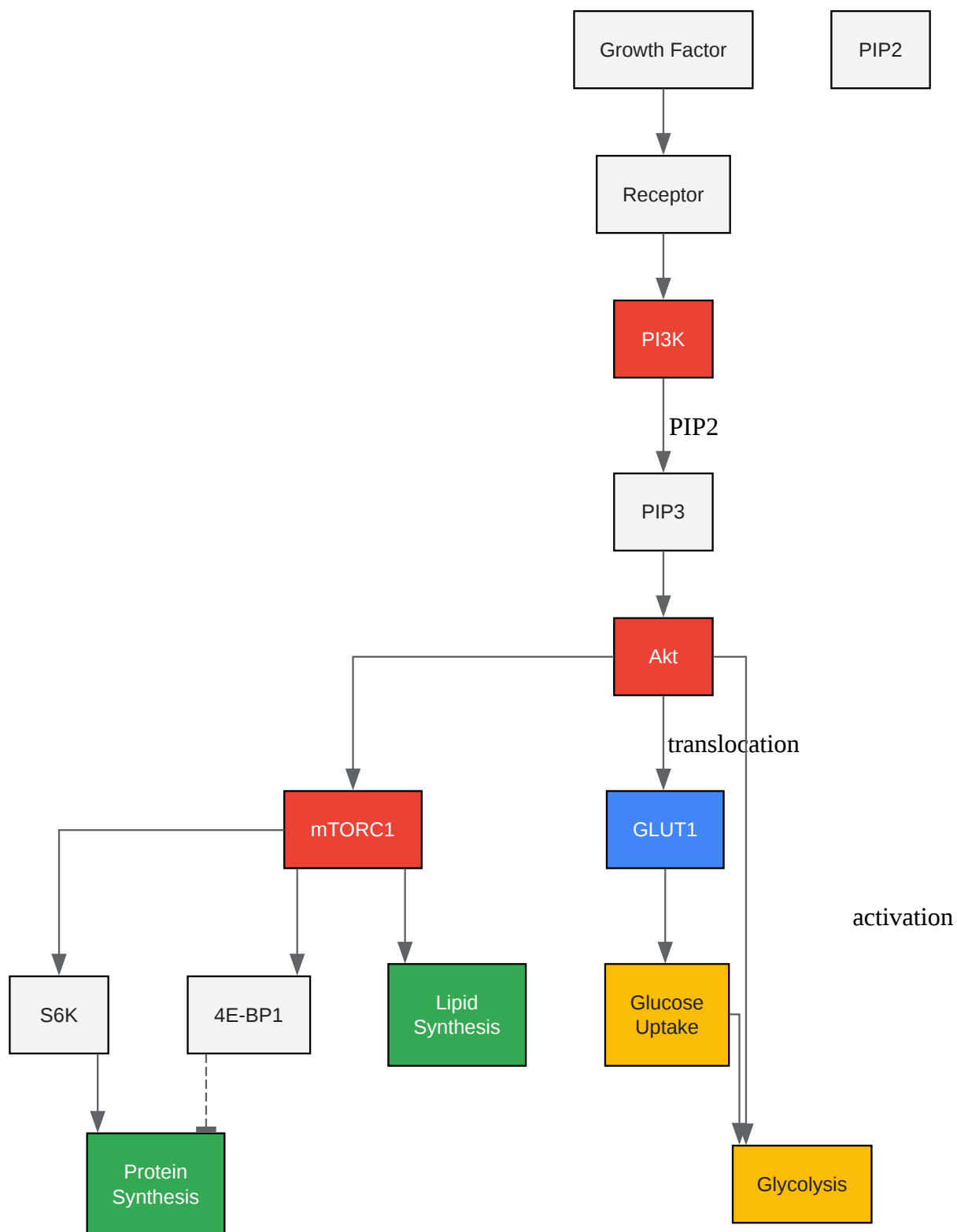

[Click to download full resolution via product page](#)

**Need Custom Synthesis?**

BenchChem offers custom synthesis for rare earth carbides and specific isotopic labeling.

Email: [info@benchchem.com](mailto:info@benchchem.com) or [Request Quote Online](#).

## References

- 1. researchgate.net [researchgate.net]
- 2. Evaluation of <sup>13</sup>C isotopic tracers for metabolic flux analysis in mammalian cells - PMC [pmc.ncbi.nlm.nih.gov]
- 3. Metabolic flux analysis of CHO cells in perfusion culture by metabolite balancing and 2D [<sup>13</sup>C, <sup>1</sup>H] COSY NMR spectroscopy - PubMed [pubmed.ncbi.nlm.nih.gov]
- 4. Mapping cancer cell metabolism with <sup>13</sup>C flux analysis: Recent progress and future challenges - PMC [pmc.ncbi.nlm.nih.gov]
- To cite this document: BenchChem. [An In-Depth Technical Guide to Metabolic Flux Analysis Using <sup>13</sup>C Tracers]. BenchChem, [2025]. [Online PDF]. Available at: [https://www.benchchem.com/product/b12412635#introduction-to-metabolic-flux-analysis-using-13c-tracers]

---

**Disclaimer & Data Validity:**

The information provided in this document is for Research Use Only (RUO) and is strictly not intended for diagnostic or therapeutic procedures. While BenchChem strives to provide accurate protocols, we make no warranties, express or implied, regarding the fitness of this product for every specific experimental setup.

**Technical Support:** The protocols provided are for reference purposes. Unsure if this reagent suits your experiment? [[Contact our Ph.D. Support Team for a compatibility check](#)]

**Need Industrial/Bulk Grade?** [Request Custom Synthesis Quote](#)

# BenchChem

Our mission is to be the trusted global source of essential and advanced chemicals, empowering scientists and researchers to drive progress in science and industry.

## Contact

Address: 3281 E Guasti Rd

Ontario, CA 91761, United States

Phone: (601) 213-4426

Email: [info@benchchem.com](mailto:info@benchchem.com)