

An In-depth Technical Guide on the Specificity and Selectivity of RMC-3943

Author: BenchChem Technical Support Team. **Date:** December 2025

Compound of Interest

Compound Name: RMC-3943

Cat. No.: B12411545

[Get Quote](#)

Notice: Publicly available information regarding the specific compound "**RMC-3943**" is not available at this time. Extensive searches for preclinical data, target profiles, and publications associated with this designation have not yielded specific results. It is possible that **RMC-3943** is an internal preclinical codename used by Revolution Medicines that has not been disclosed in public forums, a discontinued program, or a compound that has been redesignated.

While a detailed report on **RMC-3943** cannot be provided, this guide will outline the general approach and methodologies used by Revolution Medicines for characterizing the specificity and selectivity of their clinical-stage RAS(ON) inhibitors, which would be analogous to the characterization of a compound like **RMC-3943**. This information is based on public disclosures regarding their pipeline and scientific approach.

General Approach to Specificity and Selectivity of Revolution Medicines' Compounds

Revolution Medicines focuses on developing RAS(ON) inhibitors and RAS Companion Inhibitors. The specificity and selectivity of these molecules are critical for their therapeutic efficacy and safety. The company employs a comprehensive suite of biochemical, cellular, and in vivo assays to characterize their drug candidates.

Key aspects of their selectivity profiling include:

- **On-Target Potency:** Determining the binding affinity and inhibitory activity against the intended oncogenic RAS mutant (e.g., KRAS G12C, G12D, etc.) or other target proteins like SHP2 or mTORC1.
- **Selectivity Against Related Isoforms:** Assessing the activity against other RAS isoforms (e.g., HRAS, NRAS) and wild-type RAS to minimize potential off-target effects in healthy cells.
- **Broad Kinome and Off-Target Profiling:** Screening the compound against a large panel of kinases and other relevant protein targets to identify potential off-target interactions that could lead to toxicity.
- **Cellular Selectivity:** Evaluating the compound's effect on signaling pathways and cell viability in cancer cell lines harboring the target mutation versus those with wild-type RAS or other genetic backgrounds.

Methodologies for Characterizing Specificity and Selectivity

The following are detailed descriptions of the types of experimental protocols typically used in the development of targeted cancer therapies, which would be applied to a compound like **RMC-3943**.

Biochemical Assays for Target Engagement and Potency

These assays measure the direct interaction of the compound with its purified target protein.

Table 1: Representative Biochemical Assays

Assay Type	Description	Typical Parameters Measured
Enzyme-Linked Immunosorbent Assay (ELISA)	An immunoassay to quantify the binding of the inhibitor to the target protein.	IC50, Kd
Surface Plasmon Resonance (SPR)	A label-free technique to measure real-time binding kinetics of the inhibitor to the immobilized target protein.	Ka (association rate), Kd (dissociation rate), KD (equilibrium dissociation constant)
Isothermal Titration Calorimetry (ITC)	Measures the heat change upon binding of the inhibitor to the target protein to determine thermodynamic parameters.	KD, ΔH (enthalpy change), ΔS (entropy change)
Kinase Inhibition Assays	For kinase targets, these assays measure the ability of the compound to inhibit the enzymatic activity of the kinase, often using a fluorescent or luminescent readout.	IC50

Experimental Protocol: Generic ELISA-based Binding Assay

- **Coating:** Purified recombinant target protein (e.g., KRAS G12C) is coated onto the wells of a microplate.
- **Blocking:** Non-specific binding sites are blocked using a blocking agent (e.g., BSA or non-fat milk).
- **Compound Incubation:** A serial dilution of the test compound (e.g., **RMC-3943**) is added to the wells and incubated to allow for binding to the target protein.
- **Detection:** A primary antibody specific to the target protein is added, followed by a secondary antibody conjugated to an enzyme (e.g., HRP).

- Substrate Addition: A substrate for the enzyme is added, leading to a colorimetric or chemiluminescent signal.
- Data Analysis: The signal intensity is measured and plotted against the compound concentration to determine the IC₅₀ value.

Workflow for a Biochemical Binding Assay

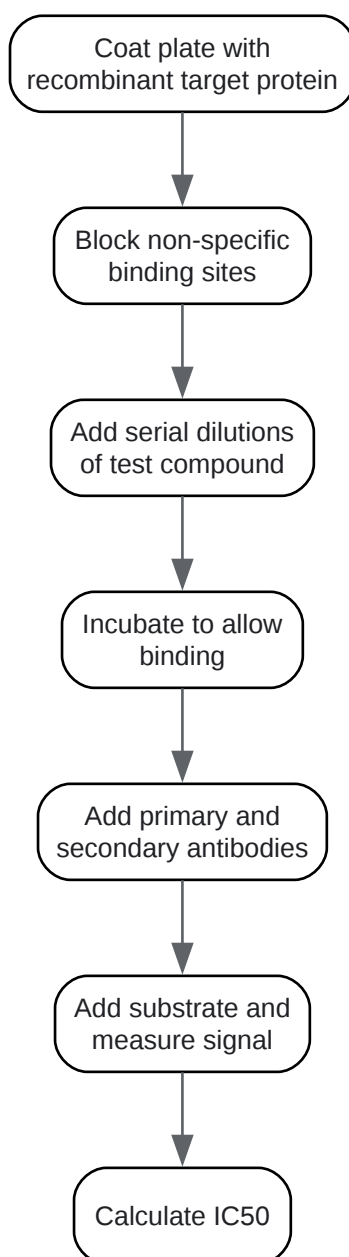

[Click to download full resolution via product page](#)

Caption: Workflow of a typical ELISA-based binding assay.

Cellular Assays for Target Engagement and Pathway Modulation

These assays assess the effect of the compound in a more biologically relevant cellular context.

Table 2: Representative Cellular Assays

Assay Type	Description	Typical Parameters Measured
Western Blotting	Measures the levels of specific proteins to assess the modulation of downstream signaling pathways (e.g., p-ERK, p-AKT).	Changes in protein phosphorylation or expression
Cell Viability/Proliferation Assays	Determines the effect of the compound on the growth and survival of cancer cell lines.	GI50 (concentration for 50% growth inhibition)
Cellular Thermal Shift Assay (CETSA)	Measures the thermal stabilization of the target protein upon compound binding in intact cells, confirming target engagement.	Shift in protein melting temperature
Immunofluorescence	Visualizes the subcellular localization of the target protein and the effect of the compound.	Changes in protein localization

Experimental Protocol: Western Blot for Pathway Analysis

- **Cell Culture and Treatment:** Cancer cell lines with the relevant mutation are cultured and treated with varying concentrations of the test compound for a specified time.

- Cell Lysis: Cells are lysed to extract total protein.
- Protein Quantification: The concentration of protein in each lysate is determined.
- SDS-PAGE and Transfer: Equal amounts of protein are separated by size using SDS-polyacrylamide gel electrophoresis and transferred to a membrane.
- Immunoblotting: The membrane is incubated with primary antibodies against the target pathway proteins (e.g., p-ERK, total ERK) and then with HRP-conjugated secondary antibodies.
- Detection: The signal is detected using a chemiluminescent substrate and an imaging system.
- Analysis: The band intensities are quantified to determine the effect of the compound on protein phosphorylation.

Signaling Pathway Modulation by a RAS(ON) Inhibitor

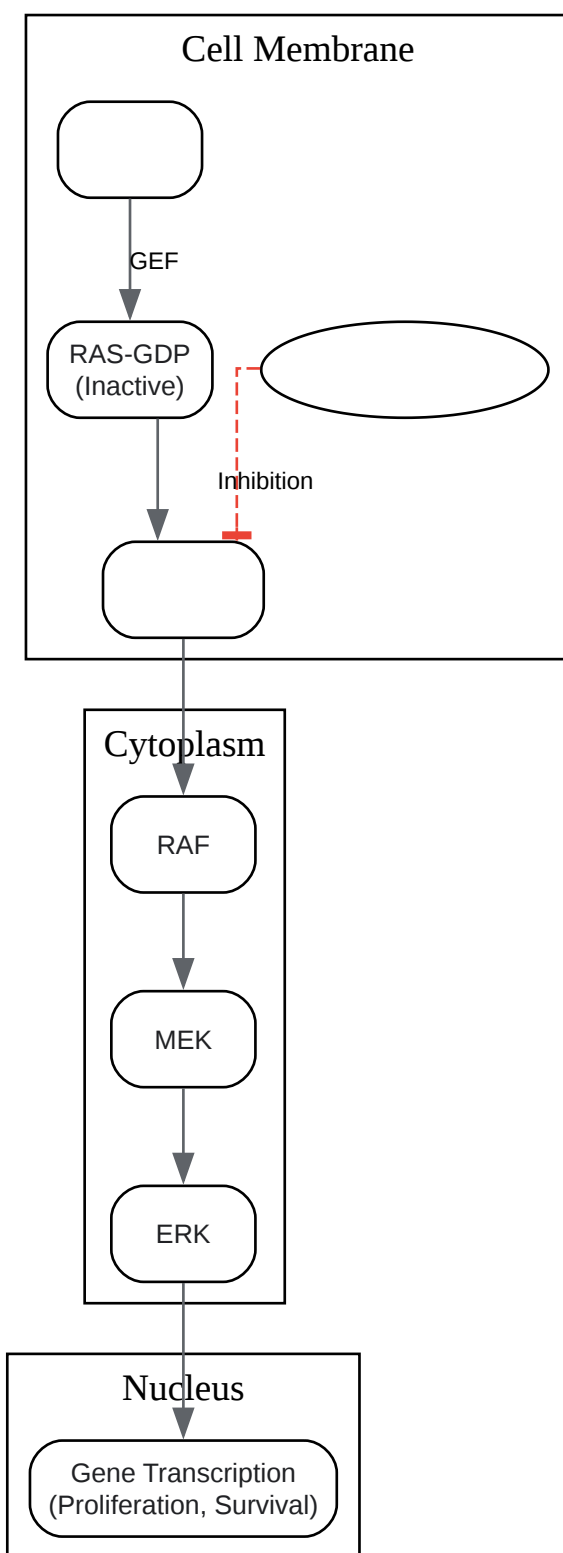

[Click to download full resolution via product page](#)

Caption: Simplified RAS signaling pathway and the inhibitory action of a RAS(ON) inhibitor.

Broad Selectivity Profiling

To ensure the safety of a drug candidate, it is crucial to assess its selectivity against a wide range of potential off-targets.

Table 3: Broad Selectivity Screening Platforms

Platform	Description	Typical Output
KinomeScan™ (DiscoverX)	A competition-based binding assay that quantitatively measures the interactions of a compound against a large panel of kinases (typically >400).	Percent of control, Kd, S-score (selectivity score)
SafetyScan™ (Eurofins)	A panel of in vitro radioligand binding and enzymatic assays against a broad range of receptors, ion channels, transporters, and enzymes known to be involved in adverse drug reactions.	Percent inhibition at a single concentration

Logical Workflow for Selectivity Profiling

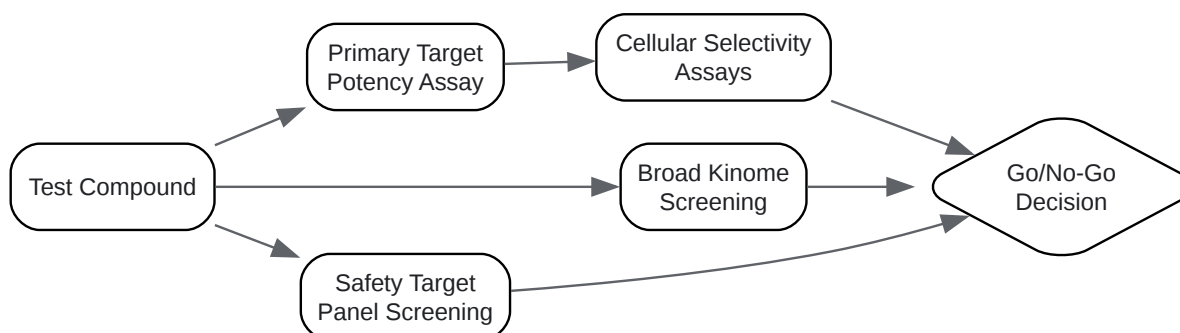

[Click to download full resolution via product page](#)

Caption: Decision-making workflow for compound selectivity profiling.

Conclusion

While specific data for **RMC-3943** is not publicly available, the methodologies described above represent the industry-standard approach for characterizing the specificity and selectivity of a targeted oncology drug candidate. A thorough evaluation using a combination of biochemical, cellular, and broad profiling assays is essential to build a comprehensive understanding of a compound's activity and potential liabilities, ultimately guiding its progression through preclinical and clinical development. Should information on **RMC-3943** become public, a similar detailed analysis of its specific data would be possible.

- To cite this document: BenchChem. [An In-depth Technical Guide on the Specificity and Selectivity of RMC-3943]. BenchChem, [2025]. [Online PDF]. Available at: [<https://www.benchchem.com/product/b12411545#rmc-3943-specificity-and-selectivity>]

Disclaimer & Data Validity:

The information provided in this document is for Research Use Only (RUO) and is strictly not intended for diagnostic or therapeutic procedures. While BenchChem strives to provide accurate protocols, we make no warranties, express or implied, regarding the fitness of this product for every specific experimental setup.

Technical Support: The protocols provided are for reference purposes. Unsure if this reagent suits your experiment? [[Contact our Ph.D. Support Team for a compatibility check](#)]

Need Industrial/Bulk Grade? [Request Custom Synthesis Quote](#)

BenchChem

Our mission is to be the trusted global source of essential and advanced chemicals, empowering scientists and researchers to drive progress in science and industry.

Contact

Address: 3281 E Guasti Rd

Ontario, CA 91761, United States

Phone: (601) 213-4426

Email: info@benchchem.com