

Technical Guide: Isolation and Characterization of Nortopsentin D

Author: BenchChem Technical Support Team. **Date:** May 2026

Compound of Interest

Compound Name: *nortopsentin D*

Cat. No.: B1241796

[Get Quote](#)

Executive Summary & Chemical Context

Nortopsentin D represents a unique divergence in the bis-indole alkaloid family.^[4] While its congeners (Nortopsentins A, B, and C) isolated from *Spongosorites ruetzleri* are renowned for potent cytotoxicity, Natural **Nortopsentin D** (isolated from *Dragmacidon* sp.) is characterized by a distinct imidazol-4-one core and a surprising lack of native cytotoxicity. Its discovery is a case study in the challenges of tautomeric structural elucidation and the critical role of methylation in unlocking biological potency.

Key Chemical Characteristics:

- Class: Bis-indole alkaloid.^{[1][2][3][5][6][7][8]}
- Core Scaffold: 5,5-disubstituted (4H)-imidazol-4-one (distinct from the imidazole core of Nortopsentins A–C).
- Primary Source: *Dragmacidon* sp.^{[1][2][3]} (Deep-water Axinellid sponge).^{[1][2][3]}
- Molecular Weight: ~376 Da (varies by halogenation).

Source Material & Ecological Targeting

Successful isolation requires precise taxonomic targeting. While Spongosorites yields the A–C series, the D variant is associated with deeper benthic zones.

Parameter	Specification	Notes
Target Genus	Dragmacidon sp.[3][6] (Order: Axinellidae)	Distinct from Spongosorites (Order: Halichondrida).
Depth Profile	Deep water (>300m)	Samples often collected via dredging or ROV (e.g., south of New Caledonia).
Preservation	Immediate freezing (-20°C)	Essential to prevent enzymatic degradation of the indole moieties.

Isolation Protocol: The Polarity-Guided Workflow

The isolation of **Nortopsentin D** utilizes a polarity-gradient extraction designed to separate the alkaloid fraction from the lipophilic sponge matrix.

Phase 1: Extraction & Partitioning

Objective: Solubilize polar alkaloids while removing fats and salts.

- Lyophilization: Freeze-dry the sponge tissue (wet weight ~1 kg) to remove water, facilitating organic solvent penetration.
- Maceration: Extract the dried tissue with MeOH/CH₂Cl₂ (1:1 v/v).
 - Why: Methanol disrupts cell membranes; Dichloromethane solubilizes the alkaloids.
- Desalting: Evaporate solvent to yield a crude gum. Partition between n-BuOH and H₂O.
 - Mechanism:[3][5] Salts remain in the aqueous phase; Nortopsentins migrate to the n-Butanol phase.

Phase 2: Chromatographic Fractionation

Objective: Isolate the bis-indole fraction.

- Flash Chromatography: Apply the n-BuOH fraction to a reversed-phase (C18) vacuum flash column.
- Elution Gradient:
 - Fraction 1: H₂O (100%) – Discard (salts/sugars).
 - Fraction 2: H₂O/MeOH (50:50) – Minor polar metabolites.
 - Fraction 3: MeOH (100%) – Target Alkaloid Fraction.
 - Fraction 4: Acetone/CH₂Cl₂ – Discard (lipids).

Phase 3: HPLC Purification (The "D" Specifics)

Nortopsentin D is often co-isolated with its biosynthetic precursor. High-resolution separation is required.

- Column: Semi-preparative C18 (e.g., Phenomenex Luna, 5 μm, 250 x 10 mm).
- Mobile Phase: Isocratic elution with 28% MeCN in 0.1% TFA/H₂O.
 - Technical Note: The Trifluoroacetic acid (TFA) modifier is critical. It protonates the imidazole nitrogens, preventing peak tailing caused by interaction with residual silanols on the column.
- Detection: UV at 280 nm (characteristic Indole absorption) and 305 nm.

Visualization: Isolation Workflow

The following diagram illustrates the logical flow from biomass to pure compound.

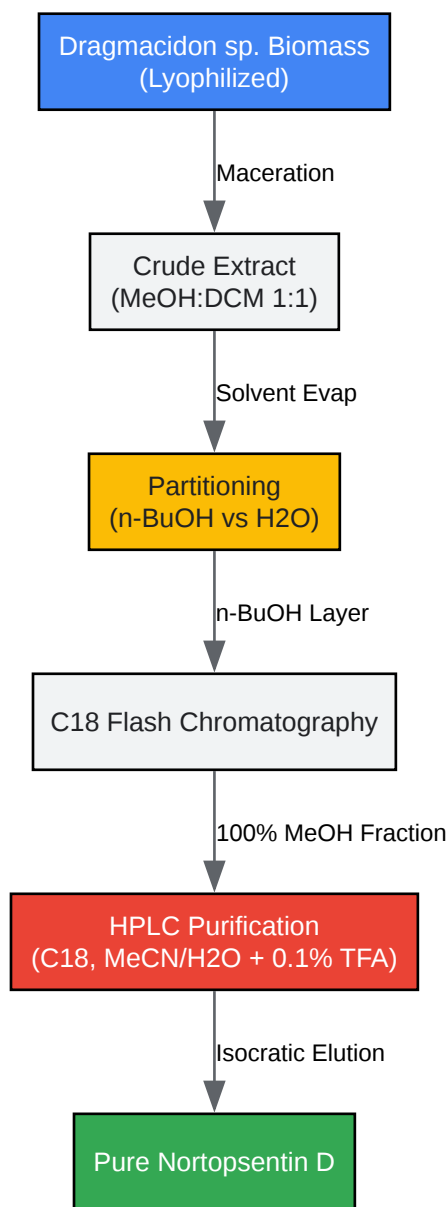

[Click to download full resolution via product page](#)

Figure 1: Step-by-step isolation workflow for **Nortopsentin D**, highlighting the critical partitioning and HPLC phases.

Structural Elucidation & The Tautomer Challenge

Defining the structure of **Nortopsentin D** is notoriously difficult due to annular tautomerism within the imidazole ring, which leads to broad, undefined NMR signals.

The Problem: Broad Signals

In the natural state, the central imidazol-4-one ring undergoes rapid proton exchange.

- Observation: ^{13}C NMR signals for the central ring are often invisible or extremely broad.
- Solution: N-Methylation.
 - Derivatization with MeI (Methyl Iodide) locks the tautomers into fixed N-methyl isomers.
 - This sharpens the NMR signals, allowing for full assignment via HMBC and NOESY correlations.

Diagnostic Spectral Features (Natural Product)

Spectroscopic Method	Diagnostic Signal	Structural Inference
UV-Vis	λ_{max} 280, 305 nm	Indole chromophore; conjugation through the imidazole.
^1H NMR (DMSO- d_6)	δ 11.5 - 12.0 (Broad singlets)	Indole NH protons (exchangeable).
^1H NMR	δ 7.0 - 8.0 (Multiplets)	Indole aromatic protons (typically 3-substituted).
HRMS	m/z ~377 $[\text{M}+\text{H}]^+$	Consistent with bis-indole formula (e.g., $\text{C}_{20}\text{H}_{17}\text{N}_4\text{O}_4$). ^[3]

Biological Activity: The "Inactive" Paradox

Unlike Nortopsentins A–C, which are potent cytotoxins, natural **Nortopsentin D** is largely inactive. However, this inactivity is a scaffold feature, not a flaw.

Comparative Bioactivity Data

The table below contrasts the natural product with its active congeners and derivatives.

Compound	Source	Target Cell Line (KB/P388)	IC ₅₀ (μM)	Activity Status
Nortopsentin A	Spongosorites	P388 (Leukemia)	7.6	Active
Nortopsentin C	Spongosorites	P388 (Leukemia)	1.7	Potent
Nortopsentin D	Dragmacidon	KB (Nasopharyngeal)	> 50	Inactive
Permethylated D	Synthetic	KB (Nasopharyngeal)	0.014	Ultra-Potent

Mechanism of Action Insight: The inactivity of natural **Nortopsentin D** suggests that the free NH groups on the central imidazolone ring may hinder cellular uptake or target binding. Methylation (as seen in the "Permethylated D" derivative) drastically increases lipophilicity and locks the conformation, restoring and enhancing cytotoxicity by orders of magnitude. This makes **Nortopsentin D** an excellent pro-drug scaffold.

References

- Mancini, I., et al. (1996). "From Inactive **Nortopsentin D**, a Novel Bis(indole) Alkaloid Isolated from the Axinellid Sponge Dragmacidon sp., to a Strongly Cytotoxic Derivative." Tetrahedron Letters. [Link](#)
- Sakemi, S., & Sun, H. H. (1991). "Nortopsentins A, B, and C. Cytotoxic and antifungal imidazolediybis[indoles] from the sponge Spongosorites ruetzleri." [9][10] The Journal of Organic Chemistry. [Link](#)
- Casapullo, A., et al. (2023). [2][3] "Nortopsentins as Leads from Marine Organisms for Anticancer and Anti-Inflammatory Agent Development." [2][3][8] Molecules. [Link](#)
- Shin, S., et al. (2018). "Bioactive Bis(indole) Alkaloids from a Spongosorites sp. [9][3][5][6][7][10][11] Sponge." Marine Drugs. [1][9][2][3][8][10][11] [Link](#)

- Gribble, G. W. (2015). "Bis-indole Alkaloids Isolated from Marine Sponges." *Marine Drugs*.^[1]^[2]^[3]^[8]^[10]^[11] [Link](#)

Need Custom Synthesis?

BenchChem offers custom synthesis for rare earth carbides and specific isotopic labeling.

Email: info@benchchem.com or [Request Quote Online](#).

Sources

- 1. [researchgate.net](https://www.researchgate.net) [[researchgate.net](https://www.researchgate.net)]
- 2. iris.unipa.it [iris.unipa.it]
- 3. Bioactive Bis(indole) Alkaloids from a Spongisorites sp. Sponge | MDPI [[mdpi.com](https://www.mdpi.com)]
- 4. [researchgate.net](https://www.researchgate.net) [[researchgate.net](https://www.researchgate.net)]
- 5. DSpace [researchrepository.universityofgalway.ie]
- 6. Bis-Indole Alkaloids Isolated from the Sponge Spongisorites calcicola Disrupt Cell Membranes of MRSA - PubMed [pubmed.ncbi.nlm.nih.gov]
- 7. Cytotoxic bisindole alkaloids from a marine sponge Spongisorites sp - PubMed [pubmed.ncbi.nlm.nih.gov]
- 8. Nortopsentins as Leads from Marine Organisms for Anticancer and Anti-Inflammatory Agent Development - PubMed [pubmed.ncbi.nlm.nih.gov]
- 9. Nortopsentins as Leads from Marine Organisms for Anticancer and Anti-Inflammatory Agent Development - PMC [pmc.ncbi.nlm.nih.gov]
- 10. pubs.acs.org [pubs.acs.org]
- 11. [researchgate.net](https://www.researchgate.net) [[researchgate.net](https://www.researchgate.net)]
- To cite this document: BenchChem. [Technical Guide: Isolation and Characterization of Nortopsentin D]. BenchChem, [2026]. [Online PDF]. Available at: [<https://www.benchchem.com/product/b1241796/docs#technical-guide-isolation-and-characterization-of-nortopsentin-d>]

Disclaimer & Data Validity:

The information provided in this document is for Research Use Only (RUO) and is strictly not intended for diagnostic or therapeutic procedures. While BenchChem strives to provide accurate protocols, we make no warranties, express or implied, regarding the fitness of this product for every specific experimental setup.

Technical Support: The protocols provided are for reference purposes. Unsure if this reagent suits your experiment?

Need Industrial/Bulk Grade? [Request Custom Synthesis Quote](#)

BenchChem

Our mission is to be the trusted global source of essential and advanced chemicals, empowering scientists and researchers to drive progress in science and industry.

Contact

Address: 3281 E Guasti Rd
Ontario, CA 91761, United States
Phone: (601) 213-4426
Email: info@benchchem.com

[Contact our Ph.D. Support Team for a compatibility check](#)