

A Comparative Guide to the NMR Characterization of PDE4 Conformational Intermediates

Author: BenchChem Technical Support Team. **Date:** April 2026

Compound of Interest

Compound Name: *PDE4 inhibitor intermediate 1*

Cat. No.: *B1241287*

[Get Quote](#)

This guide provides a comprehensive comparison of Nuclear Magnetic Resonance (NMR) spectroscopy techniques for the characterization of phosphodiesterase 4 (PDE4) intermediates. For the purpose of this guide, "intermediates" will refer to distinct conformational states of PDE4, including those stabilized by the binding of inhibitors, which are crucial for understanding its function and for the development of novel therapeutics. This document is intended for researchers, scientists, and drug development professionals.

The PDE4 Signaling Pathway: A Central Role in Cellular Regulation

Phosphodiesterase 4 (PDE4) is a family of enzymes responsible for the hydrolysis of cyclic adenosine monophosphate (cAMP), a key second messenger in a multitude of cellular signaling pathways.[1] By regulating the intracellular concentration of cAMP, PDE4 influences a wide range of physiological processes, including inflammation, cognition, and mood.[2] The inhibition of PDE4 is a validated therapeutic strategy for diseases such as chronic obstructive pulmonary disease (COPD) and psoriasis.[1]

The signaling cascade involving PDE4 begins with the activation of G protein-coupled receptors (GPCRs), which in turn activate adenylyl cyclase to produce cAMP from ATP.[1] Elevated cAMP levels lead to the activation of downstream effectors, primarily Protein Kinase A (PKA) and Exchange Protein directly Activated by cAMP (EPAC).[3] PDE4 acts as a crucial negative regulator in this pathway by hydrolyzing cAMP to AMP, thus terminating the signal.[4]

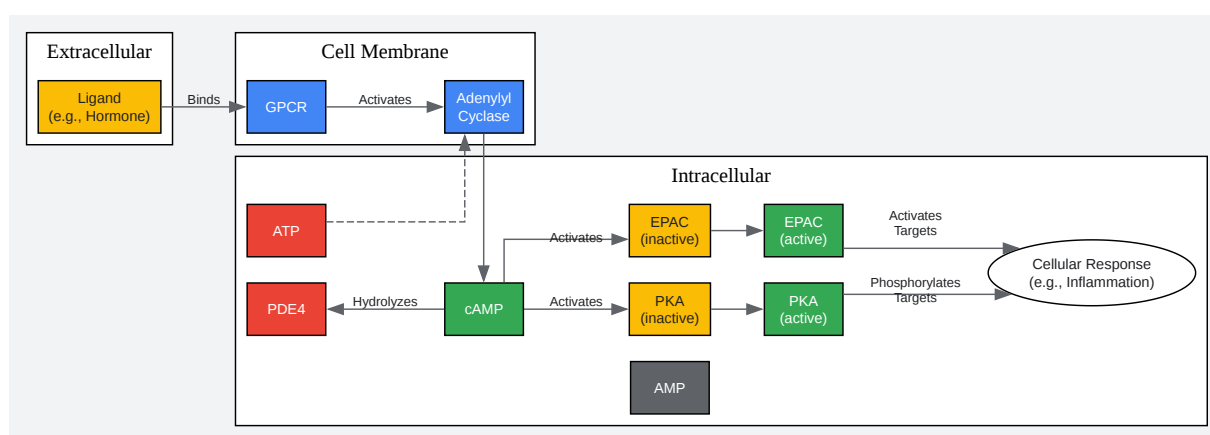

[Click to download full resolution via product page](#)

Figure 1: Simplified PDE4 signaling pathway.

NMR Methodologies for Characterizing PDE4 Conformational States

NMR spectroscopy offers a powerful suite of tools to study the structure, dynamics, and interactions of PDE4 at an atomic level in solution.

Chemical Shift Perturbation (CSP)

CSP or chemical shift mapping is a sensitive technique used to identify the binding site of a ligand on a protein.[5] By comparing the NMR spectra of a protein in the absence and

presence of a ligand, changes in the chemical shifts of specific amino acid residues can be detected.[6] Residues exhibiting significant chemical shift perturbations are likely to be part of or in close proximity to the ligand-binding site.[7]

Saturation Transfer Difference (STD) NMR

STD NMR is a ligand-observed NMR technique that is particularly useful for identifying which parts of a small molecule are in close contact with the target protein.[8] In this experiment, the protein is selectively saturated with radiofrequency pulses. This saturation is transferred to any bound ligands.[9] By subtracting the spectrum with protein saturation from a reference spectrum without saturation, a "difference" spectrum is obtained which only shows signals from the ligand that has bound to the protein.[10] The intensity of the signals in the STD spectrum is proportional to the proximity of the ligand protons to the protein surface, providing a "binding epitope" of the ligand.[11]

Relaxation Dispersion NMR

Relaxation dispersion NMR techniques, such as Carr-Purcell-Meiboom-Gill (CPMG) experiments, are used to study the conformational dynamics of proteins that exist in multiple states in equilibrium.[12] These experiments can detect and characterize sparsely populated, "invisible" conformational states that are in exchange with the major, visible ground state on the microsecond to millisecond timescale.[13][14] This is particularly relevant for studying the dynamic nature of enzyme active sites and allosteric regulation in PDE4.

Experimental Protocols

NMR Titration for Chemical Shift Perturbation (CSP) Analysis

This protocol describes a typical experiment to monitor the binding of an inhibitor to a ^{15}N -labeled PDE4 catalytic domain using a 2D ^1H - ^{15}N HSQC experiment.

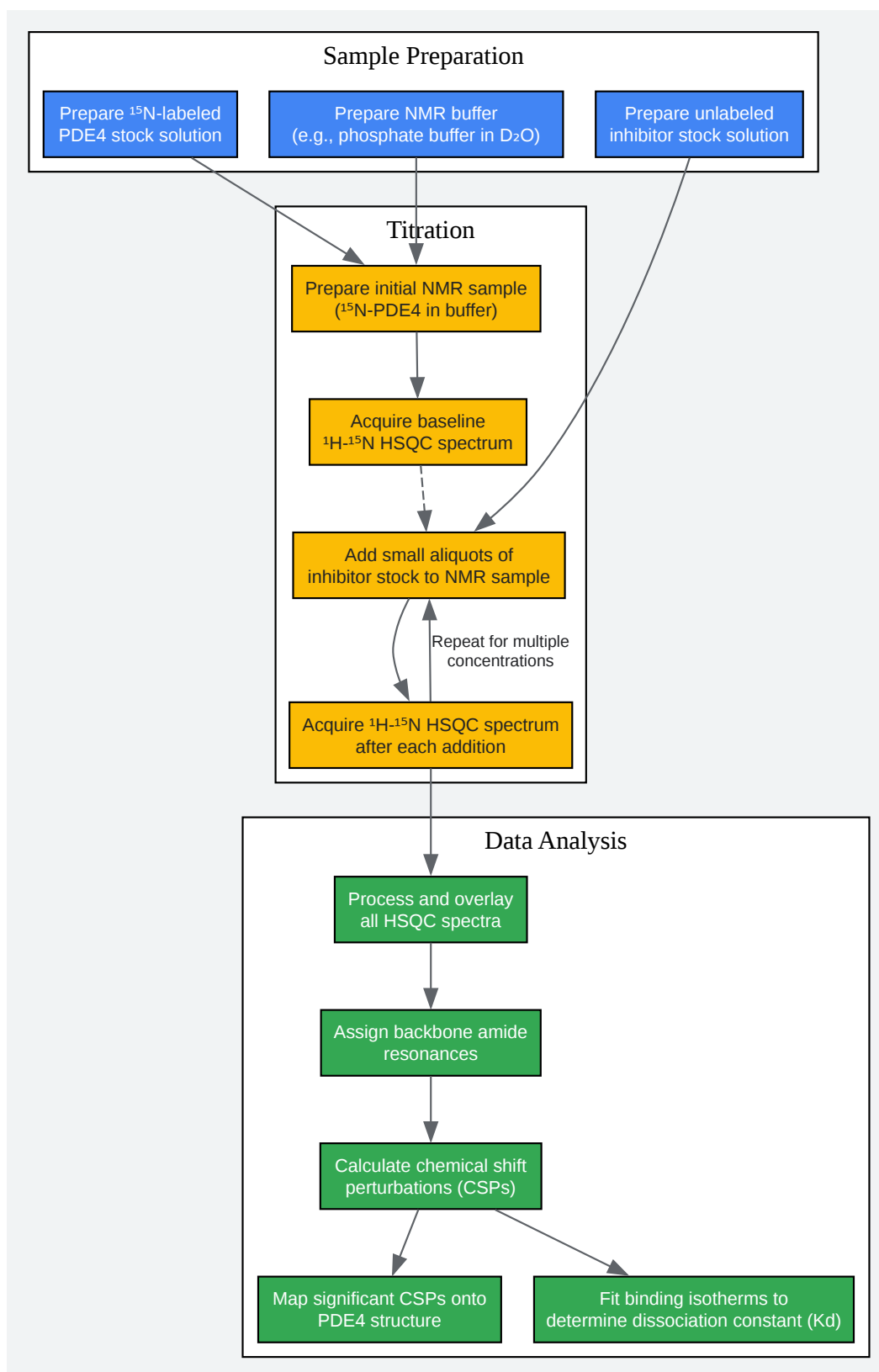

[Click to download full resolution via product page](#)

Figure 2: Workflow for an NMR CSP titration experiment.

Methodology:

- Sample Preparation:
 - Prepare a stock solution of uniformly ^{15}N -labeled PDE4 catalytic domain at a concentration of 0.1-0.5 mM in a suitable NMR buffer (e.g., 50 mM sodium phosphate, 150 mM NaCl, pH 7.0) containing 10% D_2O .[\[15\]](#)
 - Prepare a concentrated stock solution of the inhibitor in the same NMR buffer, ensuring the final concentration of any co-solvent (like DMSO) is kept constant and minimal (typically <1%) across all titration points.[\[16\]](#)
- Titration:
 - Transfer a defined volume (e.g., 500 μL) of the ^{15}N -PDE4 solution into an NMR tube.
 - Acquire a reference 2D ^1H - ^{15}N HSQC spectrum.
 - Add small, precise aliquots of the inhibitor stock solution to the NMR tube.
 - After each addition, gently mix the sample and allow it to equilibrate.
 - Acquire a 2D ^1H - ^{15}N HSQC spectrum at each inhibitor concentration. Continue until the chemical shifts of the affected residues no longer change, indicating saturation of the binding site.
- Data Analysis:
 - Process all spectra identically.
 - Overlay the series of HSQC spectra and identify the backbone amide resonances that shift upon inhibitor addition.
 - Calculate the weighted-average chemical shift perturbation (CSP) for each residue using the following equation: $\Delta\delta = \sqrt{(\Delta\delta\text{H})^2 + (\alpha * \Delta\delta\text{N})^2}$ where $\Delta\delta\text{H}$ and $\Delta\delta\text{N}$ are the changes in the proton and nitrogen chemical shifts, respectively, and α is a weighting factor (typically ~0.14-0.2).[\[6\]](#)

- Plot the CSP values against the residue number to create a chemical shift perturbation plot.
- To determine the dissociation constant (K_d), plot the CSP values for significantly perturbed residues against the molar ratio of inhibitor to protein and fit the data to a suitable binding model.^[7]

Saturation Transfer Difference (STD) NMR Protocol

This protocol outlines the steps for an STD-NMR experiment to map the binding epitope of an inhibitor to PDE4.

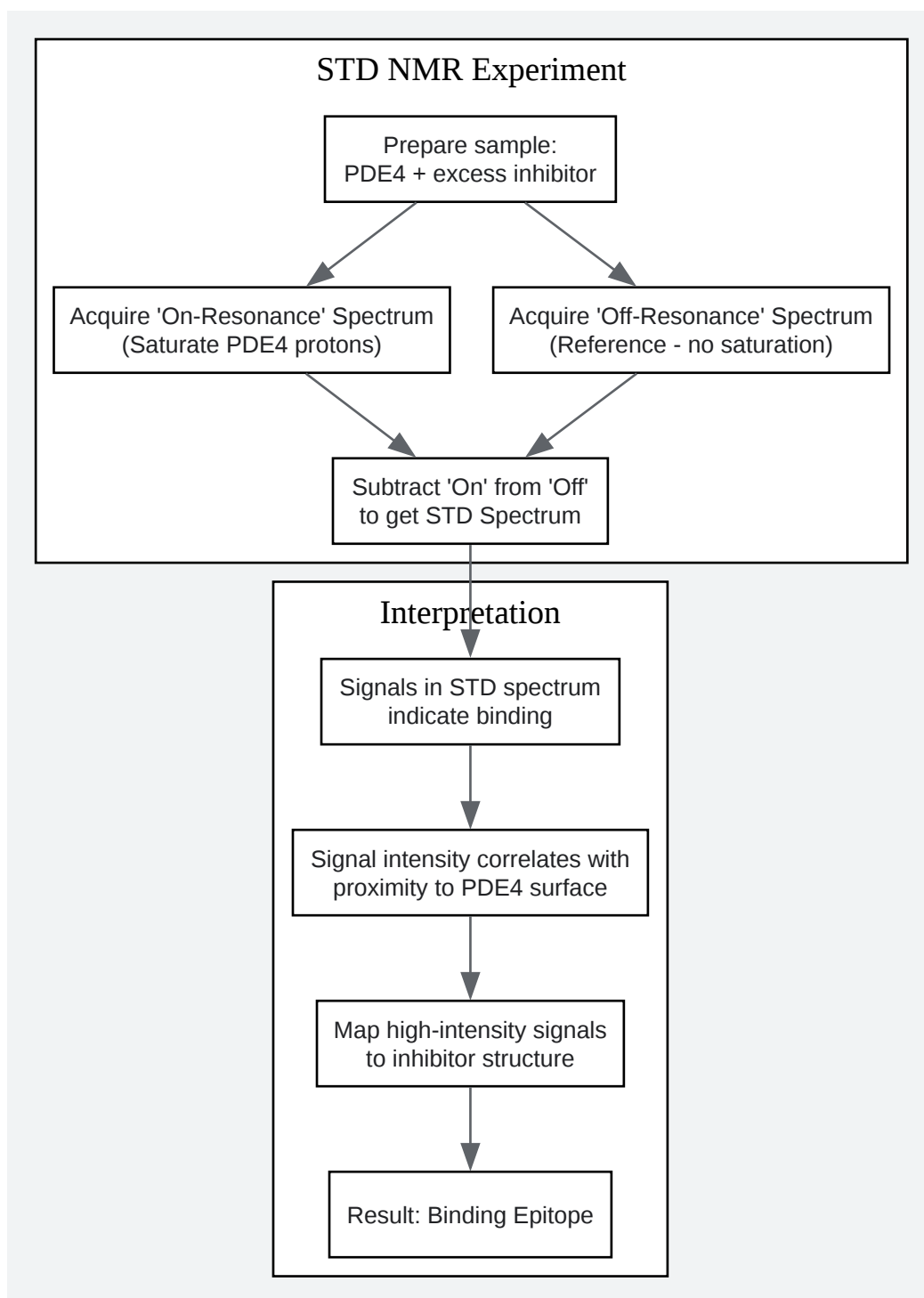

[Click to download full resolution via product page](#)

Figure 3: Logic of an STD-NMR experiment.

Methodology:

- Sample Preparation:

- Prepare a solution containing unlabeled PDE4 (typically 10-50 μM) and a significant molar excess of the inhibitor (e.g., 1:100 protein-to-ligand ratio) in a deuterated buffer.[17]
- Data Acquisition:
 - Two experiments are run in an interleaved fashion:
 - On-resonance: A long, selective saturation pulse is applied at a frequency where only the protein resonates (e.g., -0.5 ppm).
 - Off-resonance: The same saturation pulse is applied at a frequency where neither the protein nor the ligand resonates (e.g., 30 ppm), serving as a reference.[9]
 - The difference between the off-resonance and on-resonance free induction decays (FIDs) is calculated, resulting in the STD spectrum.
- Data Analysis:
 - Identify the signals in the STD spectrum, which correspond to the protons of the inhibitor that are in close contact with PDE4.
 - Calculate the STD amplification factor for each proton signal by normalizing the STD intensity to the intensity in the reference spectrum.
 - The relative STD amplification factors reveal the binding epitope of the inhibitor.

Quantitative Data Presentation

The following tables present hypothetical data to illustrate the type of quantitative information that can be obtained from NMR experiments on PDE4.

Table 1: Chemical Shift Perturbations (CSPs) of PDE4B Backbone Amides upon Inhibitor Binding

Residue	CSP with Inhibitor A (ppm)	CSP with Inhibitor B (ppm)	Location in Structure
Gly350	0.02	0.01	Distant from active site
Gln549	0.45	0.38	Active Site
Phe550	0.31	0.25	Active Site
Ile551	0.05	0.03	Near active site
Tyr552	0.28	0.52	Active Site / Allosteric Pocket
Met580	0.04	0.06	Distant from active site

Data is hypothetical. Bolded residues show significant perturbations, indicating their involvement in inhibitor binding.

Table 2: STD-NMR Amplification Factors for Inhibitor C Binding to PDE4 Isoforms

Inhibitor C Proton	STD Amplification Factor (PDE4B)	STD Amplification Factor (PDE4D)	Interpretation
Methyl (CH ₃)	100% (normalized)	100% (normalized)	Anchoring group
Phenyl H-2,6	85%	75%	Strong interaction with both
Phenyl H-3,5	40%	65%	Differential interaction
Methoxy (OCH ₃)	25%	15%	Weaker, solvent-exposed

Data is hypothetical. The difference in the Phenyl H-3,5 protons suggests a slightly different binding orientation of Inhibitor C in PDE4B versus PDE4D.

Table 3: Conformational Exchange Parameters from Relaxation Dispersion NMR

Condition	Exchange Rate (k _{ex}) (s ⁻¹)	Population of Minor State (p _B) (%)	Interpretation
Apo PDE4D	150	2.5	Intrinsic conformational flexibility
+ Allosteric Modulator X	80	1.8	Stabilizes the ground state
+ Allosteric Modulator Y	250	5.0	Promotes conformational exchange

Data is hypothetical. These parameters provide insights into how allosteric modulators affect the dynamic landscape of the enzyme.

Comparison with Other Biophysical Techniques

While NMR provides unparalleled atomic-level detail, other biophysical methods are often used in a complementary fashion to characterize PDE4 and its interactions.

Table 4: Comparison of Biophysical Techniques for Protein Characterization

Technique	Information Provided	Advantages	Limitations
NMR Spectroscopy	Atomic-resolution structure, dynamics, binding site mapping, kinetics (k_{on} , k_{off}), affinity (Kd)	Provides detailed structural and dynamic information in solution; can study weak interactions.	Requires larger amounts of stable, soluble, isotopically labeled protein; limited by protein size.
X-ray Crystallography	High-resolution 3D structure	Gold standard for atomic structure determination.	Provides a static picture in a crystal lattice, which may not represent the solution state; requires protein crystallization.
Differential Scanning Calorimetry (DSC)	Protein thermal stability (T_m)	Measures direct unfolding; useful for formulation and stability screening. [18]	Low throughput; provides global, not residue-specific, information. [19]
Circular Dichroism (CD)	Secondary structure content and conformational changes	Quick assessment of folding and stability. [19]	Low resolution; provides global information.
Size Exclusion Chromatography with Multi-Angle Light Scattering (SEC-MALS)	Oligomeric state and aggregation	Accurate determination of molecular weight in solution. [19]	Does not provide structural information.
Surface Plasmon Resonance (SPR)	Binding kinetics (k_{on} , k_{off}) and affinity (Kd)	High sensitivity, real-time analysis, requires small amounts of protein.	One binding partner must be immobilized, which can affect its activity; mass transport can be an issue.

Conclusion

NMR spectroscopy provides a versatile and powerful platform for the detailed characterization of PDE4 conformational intermediates. Techniques such as chemical shift perturbation, saturation transfer difference NMR, and relaxation dispersion offer invaluable insights into inhibitor binding modes, enzyme dynamics, and allosteric regulation at atomic resolution. When integrated with data from other biophysical methods, NMR can significantly advance our understanding of PDE4 function and guide the rational design of next-generation therapeutics.

Need Custom Synthesis?

BenchChem offers custom synthesis for rare earth carbides and specific isotopic labeling.

Email: info@benchchem.com or [Request Quote Online](#).

References

- [1. benchchem.com \[benchchem.com\]](#)
- [2. Beyond PDE4 inhibition: A comprehensive review on downstream cAMP signaling in the central nervous system - PubMed \[pubmed.ncbi.nlm.nih.gov\]](#)
- [3. Computational investigation of the dynamic control of cAMP signaling by PDE4 isoform types - PMC \[pmc.ncbi.nlm.nih.gov\]](#)
- [4. PDE4-Mediated cAMP Signalling - PMC \[pmc.ncbi.nlm.nih.gov\]](#)
- [5. researchgate.net \[researchgate.net\]](#)
- [6. researchgate.net \[researchgate.net\]](#)
- [7. The measurement of binding affinities by NMR chemical shift perturbation - PubMed \[pubmed.ncbi.nlm.nih.gov\]](#)
- [8. creative-biostructure.com \[creative-biostructure.com\]](#)
- [9. researchgate.net \[researchgate.net\]](#)
- [10. Imaging Saturation Transfer Difference \(STD\) NMR: Affinity and Specificity of Protein–Ligand Interactions from a Single NMR Sample - PMC \[pmc.ncbi.nlm.nih.gov\]](#)
- [11. Binding Moiety Mapping by Saturation Transfer Difference NMR | Springer Nature Experiments \[experiments.springernature.com\]](#)

- [12. Relaxation dispersion NMR spectroscopy for the study of protein allostery - PMC \[pmc.ncbi.nlm.nih.gov\]](#)
- [13. discovery.ucl.ac.uk \[discovery.ucl.ac.uk\]](#)
- [14. NMR Relaxation Dispersion Methods for the Structural and Dynamic Analysis of Quickly Interconverting, Low-Populated Conformational Substates - PubMed \[pubmed.ncbi.nlm.nih.gov\]](#)
- [15. nmr-bio.com \[nmr-bio.com\]](#)
- [16. ccpn.ac.uk \[ccpn.ac.uk\]](#)
- [17. researchmap.jp \[researchmap.jp\]](#)
- [18. A comparison of biophysical characterization techniques in predicting monoclonal antibody stability - PubMed \[pubmed.ncbi.nlm.nih.gov\]](#)
- [19. halolabs.com \[halolabs.com\]](#)
- To cite this document: BenchChem. [A Comparative Guide to the NMR Characterization of PDE4 Conformational Intermediates]. BenchChem, [2026]. [Online PDF]. Available at: [<https://www.benchchem.com/product/b1241287/docs#a-comparative-guide-to-the-nmr-characterization-of-pde4-conformational-intermediates>]

Disclaimer & Data Validity:

The information provided in this document is for Research Use Only (RUO) and is strictly not intended for diagnostic or therapeutic procedures. While BenchChem strives to provide accurate protocols, we make no warranties, express or implied, regarding the fitness of this product for every specific experimental setup.

Technical Support: The protocols provided are for reference purposes. Unsure if this reagent suits your experiment?

Need Industrial/Bulk Grade? [Request Custom Synthesis Quote](#)

BenchChem

Our mission is to be the trusted global source of essential and advanced chemicals, empowering scientists and researchers to drive progress in science and industry.

Contact

Address: 3281 E Guasti Rd

Ontario, CA 91761, United States

Phone: (601) 213-4426

Email: info@benchchem.com

[Contact our Ph.D. Support Team for a compatibility check](#)