

Technical Support Center: Optimizing Norphensuximide-D5 Concentration for Internal Calibration

Author: BenchChem Technical Support Team. **Date:** April 2026

Compound of Interest

Compound Name: *Norphensuximide-D5*

Cat. No.: *B12409956*

[Get Quote](#)

This technical support center provides researchers, scientists, and drug development professionals with a comprehensive guide to optimizing the concentration of **Norphensuximide-D5** for use as an internal standard in analytical assays. It includes troubleshooting advice, frequently asked questions (FAQs), detailed experimental protocols, and data presentation examples to ensure accurate and reproducible results.

Frequently Asked Questions (FAQs)

Q1: Why is a stable isotope-labeled internal standard like **Norphensuximide-D5** recommended for quantitative analysis?

A1: Stable isotope-labeled internal standards (SIL-IS) are considered the gold standard in quantitative mass spectrometry.[1][2] **Norphensuximide-D5** is chemically and structurally almost identical to the unlabeled analyte, Norphensuximide. This similarity ensures that it behaves nearly identically during sample preparation, chromatography, and ionization.[1] By adding a known concentration of **Norphensuximide-D5** to all samples, calibrators, and quality controls, it can effectively compensate for variations in extraction recovery, matrix effects (ion

suppression or enhancement), and instrument response, leading to more accurate and precise quantification of the target analyte.[3][4]

Q2: What is the ideal concentration for an internal standard?

A2: The optimal concentration for an internal standard should be high enough to provide a stable and reproducible signal but not so high that it causes detector saturation or significant isotopic interference with the analyte. A common starting point is a concentration that yields a signal intensity in the mid-range of the analyte's calibration curve. However, the ideal concentration is specific to the assay and must be determined experimentally.

Q3: How can the concentration of **Norphensuximide-D5** affect my results?

A3: An inappropriate concentration of **Norphensuximide-D5** can negatively impact the accuracy, precision, and linearity of your assay. If the concentration is too low, the signal may be weak and variable, particularly in samples with significant matrix effects, leading to poor precision. Conversely, an excessively high concentration can lead to ion suppression that disproportionately affects the analyte, potentially causing a non-linear response and inaccurate quantification.

Q4: What are "matrix effects" and can **Norphensuximide-D5** compensate for them?

A4: Matrix effects are the alteration of ionization efficiency by co-eluting compounds from the sample matrix. This can lead to either ion suppression (decreased signal) or ion enhancement (increased signal), which can significantly impact the accuracy of quantification. Because **Norphensuximide-D5** is structurally and chemically very similar to the analyte, it is affected by matrix effects in a comparable way. This allows the ratio of the analyte signal to the internal standard signal to remain constant, thus correcting for these variations.

Q5: Is it normal for **Norphensuximide-D5** to have a slightly different retention time than Norphensuximide?

A5: Yes, a small shift in retention time between an analyte and its deuterated internal standard is a known phenomenon called the "chromatographic isotope effect". Deuterated compounds can sometimes elute slightly earlier than their non-deuterated counterparts in reversed-phase chromatography. If the shift is minor and the peaks still largely overlap, it may not significantly

impact the results. However, a significant separation could lead to differential matrix effects, which would compromise the internal standard's ability to compensate accurately.

Troubleshooting Guide

Issue	Potential Cause	Recommended Solution
High Variability in Norphensuximide-D5 Peak Area	Inconsistent pipetting during sample preparation.	Ensure all pipettes are properly calibrated and use a consistent pipetting technique.
Poor mixing of the internal standard with the sample matrix.	Vortex or thoroughly mix all samples after the addition of Norphensuximide-D5 to ensure homogeneity.	
Instability of Norphensuximide-D5 in the sample matrix or processing solutions.	Evaluate the stability of Norphensuximide-D5 under your specific storage and analytical conditions.	
Low Norphensuximide-D5 Signal Intensity	Insufficient concentration of the working solution.	Increase the concentration of the Norphensuximide-D5 working solution.
Ion suppression due to matrix effects.	Optimize sample preparation to remove interfering matrix components. Evaluate different Norphensuximide-D5 concentrations to find one less affected by suppression.	
Instrument issues (e.g., dirty ion source).	Perform routine maintenance on the LC-MS system, including cleaning the ion source.	
Poor Peak Shape of Norphensuximide-D5	Co-elution with interfering substances.	Optimize chromatographic conditions (e.g., mobile phase, gradient, column) to improve separation.
Inappropriate sample extraction procedure.	Re-evaluate and optimize the sample preparation method (e.g., protein precipitation,	

	liquid-liquid extraction, solid-phase extraction).	
Non-linear Calibration Curve	Inappropriate internal standard concentration.	The IS concentration may be too high or too low, leading to differential ionization suppression across the calibration range. Re-optimize the IS concentration.
Isotopic interference ("cross-talk") from high analyte concentrations.	Use a higher mass-labeled standard if available. Some software allows for mathematical correction of isotopic contributions.	

Experimental Protocols

Protocol 1: Preparation of Stock and Working Solutions

- **Norphensuximide-D5** Stock Solution (1 mg/mL):
 - Accurately weigh a known amount of **Norphensuximide-D5**.
 - Dissolve in a suitable solvent (e.g., methanol) to a final concentration of 1 mg/mL.
 - Store at an appropriate temperature (e.g., -20°C).
- Analyte (Norphensuximide) Stock Solution (1 mg/mL):
 - Prepare in the same manner as the **Norphensuximide-D5** stock solution.
- **Norphensuximide-D5** Working Solutions:
 - Prepare a series of working solutions by diluting the stock solution. Example concentrations: 10, 50, 100, 250, and 500 ng/mL.
- Analyte Calibration Standards:

- Prepare a series of calibration standards by diluting the analyte stock solution to cover the expected concentration range of the unknown samples.

Protocol 2: Experiment to Determine Optimal Norphensuximide-D5 Concentration

- Prepare Three Sets of Samples:
 - Set A (Neat Solution): Spike a constant, mid-range concentration of the analyte into a neat solvent (e.g., mobile phase). Add each of the different **Norphensuximide-D5** working solution concentrations to these samples.
 - Set B (Post-Extraction Spike): Extract blank biological matrix (e.g., plasma) using your established procedure. Spike the extracted matrix with a constant, mid-range concentration of the analyte and each of the different **Norphensuximide-D5** working solution concentrations.
 - Set C (Pre-Extraction Spike): Spike blank biological matrix with a constant, mid-range concentration of the analyte and each of the different **Norphensuximide-D5** working solution concentrations before the extraction procedure.
- Analyze Samples:
 - Inject all prepared samples into the LC-MS/MS system and record the peak areas for both the analyte and **Norphensuximide-D5**.
- Evaluate the Data:
 - Signal Stability: For each concentration of **Norphensuximide-D5**, assess the reproducibility of the peak area across multiple injections. The coefficient of variation (%CV) should ideally be less than 15%.
 - Matrix Effect Assessment: Compare the peak area of **Norphensuximide-D5** in Set A versus Set B. A significant difference indicates the presence of matrix effects. The optimal concentration should show a consistent response.

- Recovery Assessment: Compare the peak area of **Norphensuximide-D5** in Set C versus Set B to evaluate the extraction recovery.
- Analyte Response Normalization: For the optimal **Norphensuximide-D5** concentration, prepare a full calibration curve for the analyte. The response factor (Analyte Area / Internal Standard Area) should be consistent across the entire concentration range, resulting in a linear calibration curve.

Data Presentation

Table 1: Example Evaluation of **Norphensuximide-D5** Signal Stability and Matrix Effects

Norphensuximide-D5 Concentration (ng/mL)	Mean Peak Area (Neat Solution - Set A)	%CV (n=6)	Mean Peak Area (Post-Extraction Spike - Set B)	%CV (n=6)	Matrix Effect (%)
10	55,000	18.5	35,000	22.1	-36.4
50	280,000	8.2	210,000	10.5	-25.0
100	550,000	4.5	495,000	5.1	-10.0
250	1,350,000	3.8	1,150,000	4.2	-14.8
500	2,800,000 (Saturation)	N/A	2,500,000 (Saturation)	N/A	N/A

Based on this example data, 100 ng/mL would be a good starting point for further validation as it provides a stable signal with acceptable variability and minimal matrix effect.

Table 2: Example Linearity Assessment with Optimal **Norphensuximide-D5** Concentration (100 ng/mL)

Analyte Concentration (ng/mL)	Analyte Peak Area	Norphensuximide-D5 Peak Area	Response Ratio (Analyte/IS)
1	5,200	490,000	0.0106
5	26,500	505,000	0.0525
10	51,000	498,000	0.1024
50	255,000	495,000	0.5152
100	520,000	501,000	1.0379
500	2,600,000	492,000	5.2846
Linearity (r^2)	0.9995		

Visualizations

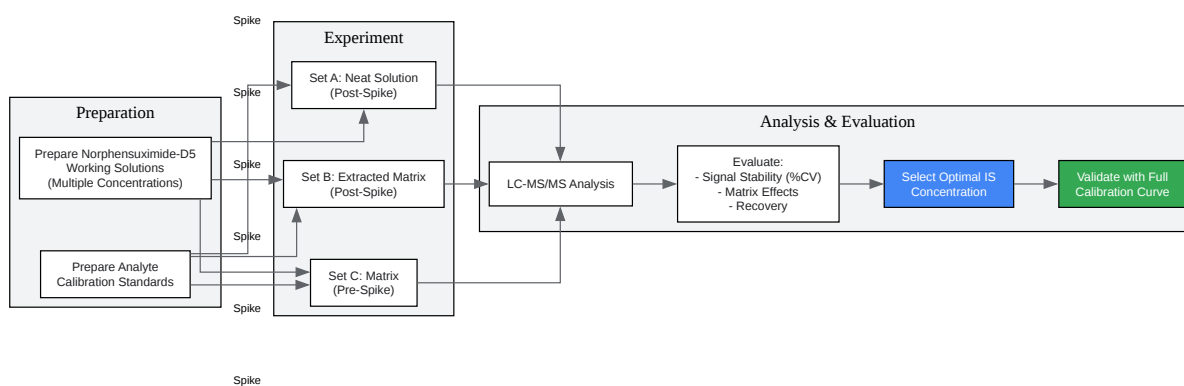

[Click to download full resolution via product page](#)

Caption: Workflow for the optimization of the internal standard concentration.

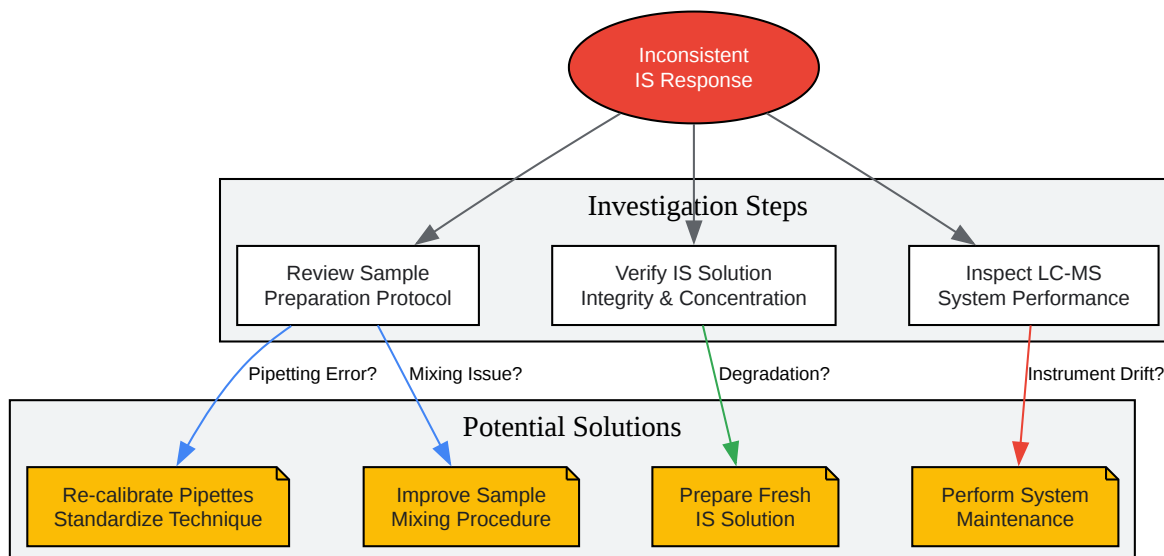

[Click to download full resolution via product page](#)

Caption: A logical diagram for troubleshooting inconsistent internal standard responses.

Need Custom Synthesis?

BenchChem offers custom synthesis for rare earth carbides and specific isotopic labeling.

Email: info@benchchem.com or [Request Quote Online](#).

References

- 1. [benchchem.com](https://www.benchchem.com) [benchchem.com]
- 2. [benchchem.com](https://www.benchchem.com) [benchchem.com]
- 3. Optimizing Laboratory-Developed LC-MS/MS Tests: Proper Use of Internal Standards - Insights from Two Troubleshooting Case Studies [labroots.com]
- 4. [nebiolab.com](https://www.nebiolab.com) [nebiolab.com]

- To cite this document: BenchChem. [Technical Support Center: Optimizing Norphensuximide-D5 Concentration for Internal Calibration]. BenchChem, [2026]. [Online PDF]. Available at: [<https://www.benchchem.com/product/b12409956/docs#technical-support-center-optimizing-norphensuximide-d5-concentration-for-internal-calibration>]

Disclaimer & Data Validity:

The information provided in this document is for Research Use Only (RUO) and is strictly not intended for diagnostic or therapeutic procedures. While BenchChem strives to provide accurate protocols, we make no warranties, express or implied, regarding the fitness of this product for every specific experimental setup.

Technical Support: The protocols provided are for reference purposes. Unsure if this reagent suits your experiment?

Need Industrial/Bulk Grade? [Request Custom Synthesis Quote](#)

BenchChem

Our mission is to be the trusted global source of essential and advanced chemicals, empowering scientists and researchers to drive progress in science and industry.

Contact

Address: 3281 E Guasti Rd
Ontario, CA 91761, United States
Phone: (601) 213-4426
Email: info@benchchem.com

[Contact our Ph.D. Support Team for a compatibility check](#)