

Application Notes and Protocols for In Vitro Profiling of Novel Small Molecules

Author: BenchChem Technical Support Team. **Date:** April 2026

Compound of Interest

Compound Name: AGL-0182-30

Cat. No.: B12409042

[Get Quote](#)

For: Researchers, scientists, and drug development professionals.

Subject: General In Vitro Experimental Setup for a Novel Investigational Compound
(Placeholder: **AGL-0182-30**)

Introduction

These application notes provide a comprehensive framework for the initial in vitro characterization of a novel small molecule compound, designated here as **AGL-0182-30**. Since **AGL-0182-30** is not a known entity in public scientific literature, this document outlines a generalized, yet detailed, series of protocols and experimental setups commonly employed in early-stage drug discovery.^{[1][2]} The goal is to establish a foundational understanding of the compound's biological activity, including its cytotoxicity, potential mechanism of action, and target engagement.

The following sections detail experimental workflows, specific assay protocols, and data presentation guidelines. These are intended to be adapted and optimized based on the specific therapeutic hypothesis for the novel compound.

Experimental Workflow and Strategy

The initial in vitro evaluation of a novel compound follows a tiered approach, starting with broad cytotoxicity profiling and progressing to more specific functional and mechanistic assays.[1] This workflow is designed to efficiently identify promising candidates and eliminate unsuitable ones early in the discovery process.

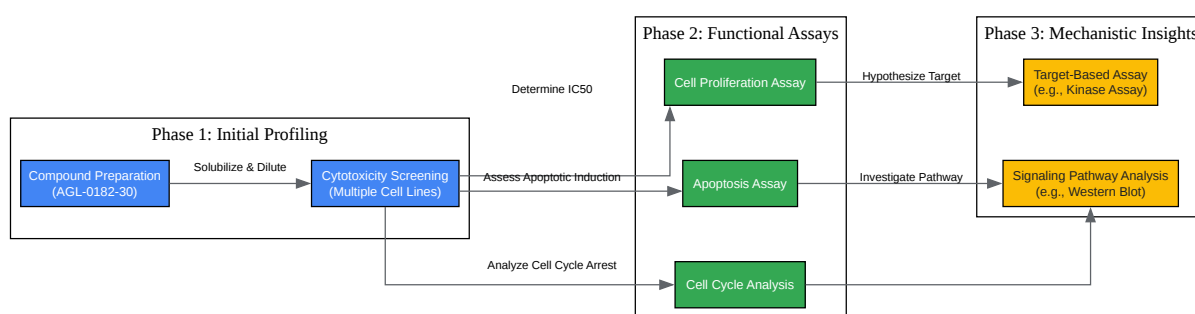

[Click to download full resolution via product page](#)

Caption: General experimental workflow for in vitro characterization.

Phase 1: Initial Profiling Protocols

Compound Preparation and Handling

Proper handling of a new chemical entity is critical for data reproducibility.

Protocol:

- Solubilization: Dissolve **AGL-0182-30** powder in a suitable solvent, typically 100% Dimethyl Sulfoxide (DMSO), to create a high-concentration stock solution (e.g., 10-50 mM).

- **Stock Aliquoting & Storage:** Aliquot the stock solution into single-use vials to avoid repeated freeze-thaw cycles. Store at -20°C or -80°C, protected from light.
- **Working Solutions:** On the day of the experiment, thaw an aliquot and prepare a series of dilutions in the appropriate cell culture medium. Ensure the final DMSO concentration in the assay does not exceed a non-toxic level, typically <0.5%.^[3]

Cytotoxicity Screening

The initial assessment of a compound's effect on cell viability is crucial for determining the appropriate concentration range for subsequent assays.^[4]

Protocol: Resazurin Reduction Assay^[4]

- **Cell Seeding:** Seed cells in a 96-well plate at a predetermined density (e.g., 5,000-10,000 cells/well) and allow them to adhere overnight.
- **Compound Treatment:** The next day, replace the medium with fresh medium containing serial dilutions of **AGL-0182-30**. Include a vehicle control (DMSO) and a positive control for cell death (e.g., staurosporine).
- **Incubation:** Incubate the plate for a specified period (e.g., 24, 48, or 72 hours) at 37°C and 5% CO₂.
- **Resazurin Addition:** Add resazurin solution to each well and incubate for 1-4 hours.
- **Signal Quantification:** Measure the fluorescence of the reduced product, resorufin, using a microplate reader.
- **Data Analysis:** Calculate the percentage of cell viability relative to the vehicle control and plot a dose-response curve to determine the half-maximal inhibitory concentration (IC₅₀).

Data Presentation: Cytotoxicity of **AGL-0182-30**

Cell Line	Seeding Density (cells/well)	Incubation Time (hours)	IC50 (μM)
Cell Line A (e.g., HeLa)	5,000	48	Data
Cell Line B (e.g., A549)	7,500	48	Data
Non-cancerous (e.g., HEK293)	10,000	48	Data

Phase 2: Functional Assay Protocols

Based on the IC50 values obtained, further functional assays can be performed to understand the cellular consequences of **AGL-0182-30** treatment.

Cell Proliferation Assay

This assay determines if the compound inhibits cell growth.

Protocol: BrdU Incorporation Assay

- Cell Seeding and Treatment: Follow steps 1 and 2 of the cytotoxicity protocol. Use concentrations around the IC50 value.
- BrdU Labeling: 2-4 hours before the end of the incubation period, add BrdU (Bromodeoxyuridine) to the culture medium.
- Fixation and Denaturation: After incubation, fix the cells and denature the DNA according to the manufacturer's protocol.
- Antibody Incubation: Incubate with an anti-BrdU antibody conjugated to an enzyme (e.g., HRP).
- Substrate Addition and Measurement: Add the enzyme's substrate and measure the resulting signal (colorimetric or chemiluminescent).

Data Presentation: Effect of **AGL-0182-30** on Proliferation

Concentration (μM)	BrdU Incorporation (% of Control)
Vehicle (DMSO)	100%
IC50 / 2	Data
IC50	Data
IC50 * 2	Data

Apoptosis Assay

This assay determines if the observed cytotoxicity is due to programmed cell death.

Protocol: Annexin V/Propidium Iodide (PI) Staining

- Cell Treatment: Treat cells in a 6-well plate with **AGL-0182-30** at relevant concentrations for a predetermined time.
- Cell Harvesting: Harvest both adherent and floating cells and wash with cold PBS.
- Staining: Resuspend cells in Annexin V binding buffer and add FITC-conjugated Annexin V and PI.
- Incubation: Incubate in the dark for 15 minutes at room temperature.
- Flow Cytometry Analysis: Analyze the stained cells by flow cytometry to distinguish between viable, early apoptotic, late apoptotic, and necrotic cells.

Phase 3: Mechanistic Insights

If the functional assays yield interesting results, the next step is to investigate the potential molecular target and signaling pathway.

Signaling Pathway Analysis

This analysis helps to identify the cellular pathways modulated by the compound. A common hypothesis is the modulation of a key signaling pathway involved in cell survival or proliferation.

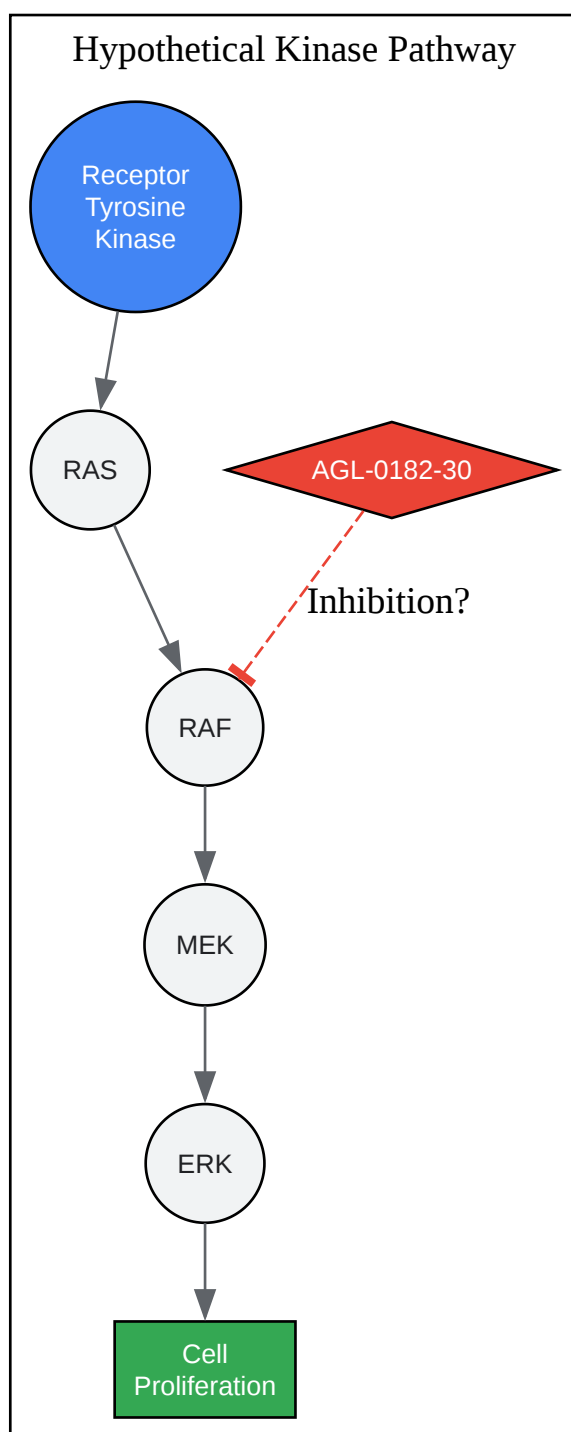

[Click to download full resolution via product page](#)

Caption: Hypothetical inhibition of the RAF kinase by **AGL-0182-30**.

Protocol: Western Blotting

- Protein Extraction: Treat cells with **AGL-0182-30**, then lyse the cells in RIPA buffer containing protease and phosphatase inhibitors.
- Protein Quantification: Determine the protein concentration of each lysate using a BCA assay.
- SDS-PAGE and Transfer: Separate protein lysates by SDS-PAGE and transfer them to a PVDF membrane.
- Blocking and Antibody Incubation: Block the membrane and incubate with primary antibodies against key signaling proteins (e.g., p-ERK, total ERK, p-AKT, total AKT, Caspase-3) overnight at 4°C.
- Secondary Antibody and Detection: Wash the membrane and incubate with HRP-conjugated secondary antibodies. Detect the signal using an enhanced chemiluminescence (ECL) substrate.

Data Presentation: Protein Expression Changes

Target Protein	Treatment (Concentration)	Fold Change vs. Vehicle
p-RAF	AGL-0182-30 (IC50)	Data
p-ERK	AGL-0182-30 (IC50)	Data
Cleaved Caspase-3	AGL-0182-30 (IC50)	Data

Conclusion

This document provides a foundational set of application notes and protocols for the initial in vitro characterization of a novel compound, **AGL-0182-30**. By following this structured approach, researchers can generate robust and reproducible data to inform decisions on the further development of the compound. All protocols should be optimized for the specific cell lines and experimental conditions used.

Need Custom Synthesis?

BenchChem offers custom synthesis for rare earth carbides and specific isotopic labeling.

Email: info@benchchem.com or [Request Quote Online](#).

References

- [1. charnwooddiscovery.com](http://charnwooddiscovery.com) [charnwooddiscovery.com]
- [2. lifesciences.danaher.com](http://lifesciences.danaher.com) [lifesciences.danaher.com]
- [3. mdpi.com](http://mdpi.com) [mdpi.com]
- [4. The Assay Guidance Manual: A Guide for In Vitro and In Vivo Assays in Early Drug Discovery](#) [promega.com.cn]
- To cite this document: BenchChem. [Application Notes and Protocols for In Vitro Profiling of Novel Small Molecules]. BenchChem, [2026]. [Online PDF]. Available at: [<https://www.benchchem.com/product/b12409042/docs#application-notes-and-protocols-for-in-vitro-profiling-of-novel-small-molecules>]

Disclaimer & Data Validity:

The information provided in this document is for Research Use Only (RUO) and is strictly not intended for diagnostic or therapeutic procedures. While BenchChem strives to provide accurate protocols, we make no warranties, express or implied, regarding the fitness of this product for every specific experimental setup.

Technical Support: The protocols provided are for reference purposes. Unsure if this reagent suits your experiment?

Need Industrial/Bulk Grade? [Request Custom Synthesis Quote](#)

BenchChem

Our mission is to be the trusted global source of essential and advanced chemicals, empowering scientists and researchers to drive progress in science and industry.

Contact

Address: 3281 E Guasti Rd

Ontario, CA 91761, United States

Phone: (601) 213-4426

Email: info@benchchem.com

[Contact our Ph.D. Support Team for a compatibility check](#)