

A Comparative Guide: Purine Riboside Triphosphate vs. Tubercidin Triphosphate

Author: BenchChem Technical Support Team. **Date:** April 2026

Compound of Interest

Compound Name: *Purine riboside triphosphate*

Cat. No.: *B12409437*

[Get Quote](#)

For researchers and professionals in drug development, understanding the nuanced differences between ATP analogs is critical for experimental design and therapeutic application. This guide provides an objective comparison of two prominent adenosine triphosphate (ATP) analogs: **Purine Riboside Triphosphate** (also known as Nebularine Triphosphate) and Tubercidin Triphosphate. This comparison is based on available experimental data concerning their biochemical interactions and cellular effects.

At a Glance: Key Differences

Feature	Purine Riboside Triphosphate (Nebularine Triphosphate)	Tubercidin Triphosphate
Structure	A purine nucleoside triphosphate lacking the amino group at the 6-position of the adenine ring.	An analog of ATP where the N-7 of the adenine ring is replaced by a CH group.[1]
Primary Mechanism	Primarily acts as a competitive inhibitor of ATP-dependent enzymes.	Functions as a substrate for various enzymes and can be incorporated into RNA.
Interaction with RNA Polymerase	Competitively inhibits RNA polymerase with respect to ATP; not incorporated into RNA.[2]	Can be incorporated into RNA, leading to downstream cytotoxic effects.[3]
Interaction with Myosin/Actomyosin	Data not readily available.	Serves as a substrate, being hydrolyzed by actomyosin at a faster rate than ATP.[1]
Cytotoxicity	Exhibits cytotoxic effects.	Generally exhibits higher cytotoxicity.

Quantitative Data Comparison

The following tables summarize the available quantitative data for Tubercidin Triphosphate's interaction with actomyosin and the cytotoxic effects of the parent nucleosides, which are intracellularly converted to their triphosphate forms. A direct quantitative comparison of both triphosphate analogs in the same experimental system is not readily available in the reviewed literature.

Table 1: Kinetic Parameters of Tubercidin Triphosphate (TuTP) with Actomyosin[1]

Substrate	Enzyme	Vmax	Km
Tubercidin Triphosphate (TuTP)	Actomyosin	~4 times that of ATP	Same order of magnitude as ATP
ATP	Actomyosin	Reference	Reference

Table 2: Cytotoxicity of Parent Nucleosides (IC50 Values)

Compound	Cell Line	IC50	Reference
Tubercidin	Vero	14.23 μM	[4]
Tubercidin	LLC-PK1	Not specified, but effective at 0.25–1 μM	[4]
Nebularine	Amaranthus Bioassay	60% inhibition at 20 μM (8-fold excess over kinetin)	[5]

Note: The cytotoxicity of the triphosphate forms is inferred from the activity of their parent nucleosides, which are phosphorylated intracellularly.

Interaction with Key Enzymes

RNA Polymerase

Purine Riboside Triphosphate acts as a classic competitive inhibitor of E. coli RNA polymerase. It competes with the natural substrate, ATP, for the active site but does not get incorporated into the growing RNA chain.[2] This lack of incorporation prevents the downstream effects associated with modified RNA.

Tubercidin Triphosphate, in contrast, can be utilized as a substrate by RNA polymerase and incorporated into RNA.[3] This incorporation can disrupt RNA secondary structure and interfere with protein synthesis, contributing to its cytotoxic effects.

Myosin and Actomyosin

Tubercidin Triphosphate has been shown to be a substrate for myosin and actomyosin. In fact, it is hydrolyzed by actomyosin at a rate approximately four times faster than ATP, while the Michaelis constant (K_m) remains in the same order of magnitude.[1] The rate of superprecipitation induced by TuTP was found to be about half that of ATP.[1]

No direct data on the interaction of **Purine Riboside Triphosphate** with myosin or actomyosin was identified in the reviewed literature.

Cellular Effects and Signaling Pathways

Both purine riboside and tubercidin are cytotoxic, which is attributed to their intracellular conversion to the triphosphate forms that interfere with essential cellular processes. Tubercidin generally exhibits higher potency.

As ATP analogs, both molecules have the potential to interact with purinergic signaling pathways, which are crucial in a multitude of physiological processes. Extracellular ATP and its analogs can activate P2 receptors (P2X and P2Y), initiating downstream signaling cascades.

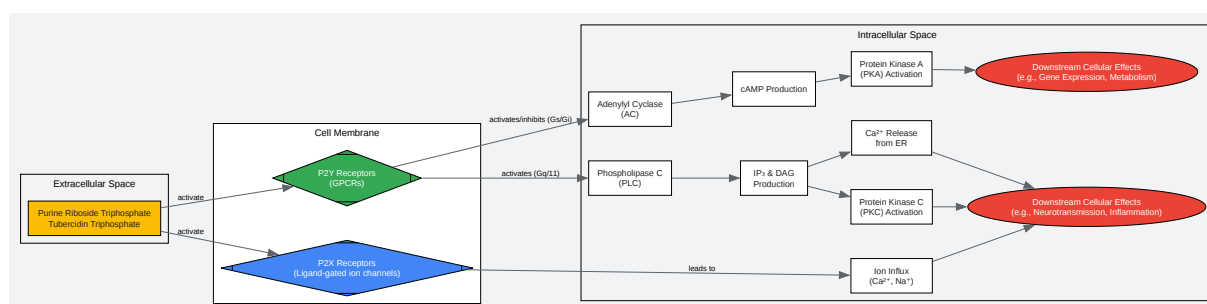

[Click to download full resolution via product page](#)

Fig. 1: Generalized Purinergic Signaling Pathway

The diagram above illustrates the general mechanism of purinergic signaling initiated by extracellular nucleotides. While both **purine riboside triphosphate** and tubercidin triphosphate are expected to interact with this pathway, the specific receptor affinities and downstream consequences for each analog require further investigation. A recent study has shown that tubercidin can promote the activation of the RIG-I/NF- κ B signaling pathway, leading to increased expression of type I interferons and inflammatory cytokines.[6]

Experimental Protocols

Myosin ATPase Activity Assay

This protocol is adapted from standard methods for measuring myosin ATPase activity and can be used to compare ATP analogs.[2][7]

Objective: To determine the rate of ATP hydrolysis by myosin or actomyosin.

Materials:

- Myosin or actomyosin preparation
- Assay Buffer: 15 mM HEPES (pH 7.5), 50 mM KCl, 1 mM MgCl₂, 0.1 mM EGTA
- ATP or ATP analog stock solution (e.g., 10 mM)
- [γ -³²P]ATP (for radiometric assay) or a coupled enzyme system for spectrophotometric assay (e.g., pyruvate kinase/lactate dehydrogenase)
- Quenching solution (for radiometric assay): e.g., 10% SDS or perchloric acid
- Scintillation fluid and counter (for radiometric assay) or spectrophotometer (for coupled assay)

Procedure (Radiometric Assay):

- Prepare reaction mixtures in microcentrifuge tubes, each containing assay buffer and the desired concentration of the ATP analog. Include a trace amount of [γ -³²P]ATP.

- Equilibrate the tubes to the desired temperature (e.g., 25°C or 37°C).
- Initiate the reaction by adding the myosin/actomyosin preparation to the tubes.
- At specific time points, stop the reaction by adding the quenching solution.
- Separate the released ^{32}P -labeled inorganic phosphate from the unhydrolyzed $[\gamma\text{-}^{32}\text{P}]\text{ATP}$ using an extraction method (e.g., isobutanol/benzene extraction with ammonium molybdate).
- Measure the radioactivity of the released phosphate using a scintillation counter.
- Calculate the rate of ATP hydrolysis from the amount of phosphate released over time.

E. coli RNA Polymerase Inhibition Assay

This protocol is based on general procedures for assessing the inhibitory potential of compounds against RNA polymerase.[\[8\]](#)[\[9\]](#)

Objective: To determine the inhibitory effect of ATP analogs on RNA polymerase activity.

Materials:

- E. coli RNA polymerase holoenzyme
- DNA template (e.g., a plasmid or a synthetic oligonucleotide with a promoter sequence)
- Assay Buffer: 40 mM Tris-HCl (pH 8.0), 10 mM MgCl_2 , 100 mM KCl, 1 mM DTT
- Ribonucleoside triphosphates (NTPs): ATP, GTP, CTP, UTP (and the ATP analog to be tested)
- $[\alpha\text{-}^{32}\text{P}]\text{UTP}$ or a fluorescent RNA dye for detection
- Stop solution: e.g., EDTA in formamide
- Polyacrylamide gel for electrophoresis or a fluorescence plate reader

Procedure:

- Set up reaction mixtures containing the assay buffer, DNA template, and all NTPs except ATP.
- Add varying concentrations of the ATP analog (e.g., **Purine Riboside Triphosphate**) and a fixed, competing concentration of ATP. Include a radioactive or fluorescent label for the transcript.
- Initiate the transcription reaction by adding the E. coli RNA polymerase.
- Incubate the reaction at 37°C for a defined period (e.g., 30-60 minutes).
- Stop the reaction by adding the stop solution.
- Analyze the synthesized RNA. For radiometric assays, this is typically done by denaturing polyacrylamide gel electrophoresis followed by autoradiography. For fluorescent assays, the fluorescence intensity can be measured directly in the reaction plate.
- Quantify the amount of RNA produced in the presence of the inhibitor relative to the control (no inhibitor) to determine the extent of inhibition. Kinetic parameters such as the inhibition constant (K_i) can be determined by performing the assay at multiple substrate and inhibitor concentrations.

Fig. 2: Workflow for RNA Polymerase Inhibition Assay

Conclusion

Purine Riboside Triphosphate and Tubercidin Triphosphate, while both being analogs of ATP, exhibit distinct mechanisms of action and biochemical properties. **Purine Riboside Triphosphate** primarily functions as a competitive inhibitor, particularly of RNA polymerase, without being incorporated into the nascent RNA chain. In contrast, Tubercidin Triphosphate can act as a substrate for enzymes like actomyosin and RNA polymerase, with its incorporation into RNA being a key aspect of its biological activity.

The choice between these two analogs in a research or drug development context will critically depend on the desired experimental outcome. If the goal is to competitively inhibit an ATP-dependent enzyme without altering the integrity of nucleic acids, **Purine Riboside Triphosphate** would be the more suitable candidate. Conversely, if the aim is to introduce a modified nucleotide into RNA to study its downstream effects or to leverage its potent cytotoxic

properties, Tubercidin Triphosphate would be the analog of choice. Further head-to-head comparative studies in various biological systems are warranted to fully elucidate their differential effects and therapeutic potential.

Need Custom Synthesis?

BenchChem offers custom synthesis for rare earth carbides and specific isotopic labeling.

Email: info@benchchem.com or [Request Quote Online](#).

References

- 1. A study on the reactions of tubercidin triphosphate with myosin and actomyosin - PubMed [pubmed.ncbi.nlm.nih.gov]
- 2. ohsu.edu [ohsu.edu]
- 3. Favored incorporation of tubercidin in poly(adenylic, 7-deazadenylic acids) and their function as messenger ribonucleic acids in protein synthesis - PubMed [pubmed.ncbi.nlm.nih.gov]
- 4. E. coli 6S RNA complexed to RNA polymerase maintains product RNA synthesis at low cellular ATP levels by initiation with noncanonical initiator nucleotides - PMC [pmc.ncbi.nlm.nih.gov]
- 5. cytotoxicity ic50 values: Topics by Science.gov [science.gov]
- 6. Tubercidin inhibits PRRSV replication via RIG-I/NF- κ B pathways and interrupting viral nsp2 synthesis - PMC [pmc.ncbi.nlm.nih.gov]
- 7. KINETIC AND EQUILIBRIUM ANALYSIS OF THE MYOSIN ATPase - PMC [pmc.ncbi.nlm.nih.gov]
- 8. fnkprddata.blob.core.windows.net [fnkprddata.blob.core.windows.net]
- 9. RNA polymerase assay kit [profoldin.com]
- To cite this document: BenchChem. [A Comparative Guide: Purine Riboside Triphosphate vs. Tubercidin Triphosphate]. BenchChem, [2026]. [Online PDF]. Available at: [<https://www.benchchem.com/product/b12409437/docs#a-comparative-guide-purine-riboside-triphosphate-vs-tubercidin-triphosphate>]

Disclaimer & Data Validity:

The information provided in this document is for Research Use Only (RUO) and is strictly not intended for diagnostic or therapeutic procedures. While BenchChem strives to provide accurate protocols, we make no warranties, express or implied, regarding the fitness of this product for every specific experimental setup.

Technical Support: The protocols provided are for reference purposes. Unsure if this reagent suits your experiment?

Need Industrial/Bulk Grade? [Request Custom Synthesis Quote](#)

BenchChem

Our mission is to be the trusted global source of essential and advanced chemicals, empowering scientists and researchers to drive progress in science and industry.

Contact

Address: 3281 E Guasti Rd
Ontario, CA 91761, United States
Phone: (601) 213-4426
Email: info@benchchem.com

[Contact our Ph.D. Support Team for a compatibility check](#)