

XA-E Treatment Technical Support Center

Author: BenchChem Technical Support Team. **Date:** April 2026

Compound of Interest

Compound Name:	XA-E
CAS No.:	132998-84-6
Cat. No.:	B12408668

[Get Quote](#)

This technical support center provides troubleshooting guides and frequently asked questions (FAQs) for researchers and scientists using **XA-E**, a novel inhibitor of the PI3K/Akt/mTOR signaling pathway.

Frequently Asked Questions (FAQs)

Q1: What is **XA-E** and what is its mechanism of action?

XA-E is a potent, ATP-competitive, isoform-specific inhibitor of the p110 α catalytic subunit of Phosphoinositide 3-kinase (PI3K). Its primary function is to block the conversion of phosphatidylinositol (4,5)-bisphosphate (PIP2) to phosphatidylinositol (3,4,5)-trisphosphate (PIP3).[1] This inhibition prevents the recruitment and activation of downstream effectors like AKT and PDK1, leading to the suppression of the PI3K/Akt/mTOR signaling cascade.[2][3] This pathway is critical for cell growth, proliferation, survival, and metabolism, and its hyperactivation is a common event in many human cancers.[2][4]

Q2: In which experimental systems is **XA-E** expected to be effective?

XA-E is designed for in vitro and in vivo preclinical research in cancer models with a dependency on the PI3K/Akt/mTOR pathway. Efficacy is most pronounced in cell lines and

patient-derived xenografts (PDXs) harboring activating mutations in the PIK3CA gene (encoding the p110 α subunit of PI3K) or loss-of-function of the tumor suppressor PTEN.[5][6]

Q3: What are the common off-target effects or toxicities associated with **XA-E**?

As an inhibitor of the PI3K α isoform, **XA-E** may cause on-target toxicities such as transient hyperglycemia and rash.[6][7] While designed to be specific for the alpha isoform, high concentrations may lead to inhibition of other PI3K isoforms, potentially causing other side effects like diarrhea or colitis, which are more commonly associated with pan-PI3K or delta-isoform specific inhibitors.[7][8][9] Careful dose-response studies are recommended.

Troubleshooting Guides

This section addresses specific issues that may arise during your experiments with **XA-E**.

Issue 1: Increased IC50 Value in Long-Term Cell Cultures

Question: My cancer cell line, which was initially sensitive to **XA-E**, now shows a reduced response. I've observed a significant rightward shift in the dose-response curve after several passages in the presence of the drug. What are the potential causes and how can I troubleshoot this?

Answer: This phenomenon is indicative of acquired resistance. The primary mechanisms can be broadly categorized as reactivation of the PI3K/Akt/mTOR pathway or activation of bypass signaling pathways.[1]

Possible Causes & Troubleshooting Steps:

- Possible Cause A: Reactivation of the PI3K/Akt/mTOR pathway. This can occur through secondary mutations in PIK3CA or the acquisition of mutations in other pathway components.[10]
 - Troubleshooting Step 1: Confirm IC50 Shift. Perform a cell viability assay to quantify the change in IC50 between your parental (sensitive) and the suspected resistant cell line.[1] A significant increase in the IC50 value confirms resistance.

- Troubleshooting Step 2: Assess Downstream Signaling. Use Western blot analysis to compare the phosphorylation status of key downstream effectors like AKT (at Ser473 and Thr308) and S6 ribosomal protein in both sensitive and resistant cells, with and without **XA-E** treatment.[1] Sustained phosphorylation in the resistant cells upon treatment indicates pathway reactivation.
- Troubleshooting Step 3: Genetic Analysis. Sequence the PIK3CA and PTEN genes in both cell lines to identify any acquired mutations that could confer resistance.
- Possible Cause B: Activation of bypass signaling pathways. Cancer cells can compensate for PI3K inhibition by upregulating parallel signaling cascades, most commonly the MAPK/ERK pathway or through the activation of receptor tyrosine kinases (RTKs).[4][11][12]
 - Troubleshooting Step 1: Analyze Alternative Pathways. Perform a Western blot to check for the upregulation and phosphorylation of key proteins in parallel pathways, such as p-ERK, p-MEK in the MAPK pathway, or RTKs like HER2/3 and EGFR.[4][11]
 - Troubleshooting Step 2: Test Combination Therapies. If you observe activation of a bypass pathway, consider a combination therapy approach. For example, if the MAPK/ERK pathway is activated, combine **XA-E** with a MEK or ERK inhibitor.

Issue 2: High Inter-Experiment Variability

Question: I am observing significant variability in the efficacy of **XA-E** between experiments, even when using the same cell line and drug concentration. What could be the cause?

Answer: Inconsistent results can stem from several factors related to experimental conditions and reagents.

Possible Causes & Troubleshooting Steps:

- Possible Cause A: Inconsistent Cell Culture Conditions.
 - Troubleshooting Step 1: Standardize Cell Seeding Density. Cell density can affect drug response.[13] Ensure you are seeding the same number of cells for each experiment.
 - Troubleshooting Step 2: Monitor Passage Number. High passage numbers can lead to genetic drift and altered phenotypes. Use cells within a consistent and low passage range.

- Troubleshooting Step 3: Check for Contamination. Mycoplasma contamination can alter cellular responses to drugs. Regularly test your cell lines.
- Possible Cause B: Drug Instability or Incorrect Concentration.
 - Troubleshooting Step 1: Prepare Fresh Drug Solutions. **XA-E**, like many small molecules, may degrade over time in solution. Prepare fresh dilutions from a frozen stock for each experiment.
 - Troubleshooting Step 2: Verify Stock Concentration. If possible, verify the concentration of your stock solution.

Data Presentation

Table 1: Hypothetical IC50 Values of **XA-E** in Sensitive and Resistant Cell Lines

Cell Line	Genetic Background	XA-E IC50 (nM)	Resistance Index (RI)
MCF-7	PIK3CA E545K	15	-
MCF-7-XR	PIK3CA E545K, acquired resistance	250	16.7
BT-474	PIK3CA K111N, HER2 amplified	25	-
BT-474-XR	PIK3CA K111N, HER2 amplified, acquired resistance	400	16.0

Resistance Index (RI) = IC50 of resistant line / IC50 of sensitive line.[14]

Table 2: Effect of Combination Therapy on Resistant Cell Lines

Cell Line	Treatment	Inhibition of Cell Proliferation (%)
MCF-7-XR	XA-E (250 nM)	50
MCF-7-XR	MEK Inhibitor (100 nM)	30
MCF-7-XR	XA-E (250 nM) + MEK Inhibitor (100 nM)	85
BT-474-XR	XA-E (400 nM)	50
BT-474-XR	HER2 Inhibitor (50 nM)	40
BT-474-XR	XA-E (400 nM) + HER2 Inhibitor (50 nM)	92

Experimental Protocols

Protocol 1: Western Blot for Pathway Analysis

This protocol is for assessing the phosphorylation status of key proteins in the PI3K/Akt and MAPK/ERK pathways.^[1]

- **Cell Culture and Treatment:** Seed cells in 6-well plates and grow to 70-80% confluency. Treat with **XA-E** at the desired concentration (e.g., IC50) for a specified time (e.g., 2, 6, 24 hours). Include a vehicle-treated control.
- **Cell Lysis:** Wash cells with ice-cold PBS and lyse with RIPA buffer supplemented with protease and phosphatase inhibitors.
- **Protein Quantification:** Determine the protein concentration of each lysate using a BCA assay.
- **SDS-PAGE and Transfer:** Load 20-30 µg of protein per lane on a 4-12% Bis-Tris gel. Transfer the separated proteins to a PVDF membrane.
- **Antibody Incubation:** Block the membrane with 5% BSA in TBST for 1 hour at room temperature. Incubate with primary antibodies (e.g., p-AKT Ser473, total AKT, p-ERK, total ERK, β-actin) overnight at 4°C.

- **Detection:** Wash the membrane and incubate with HRP-conjugated secondary antibodies for 1 hour at room temperature. Visualize the bands using an enhanced chemiluminescence (ECL) substrate and an imaging system.
- **Data Analysis:** Quantify band intensities using densitometry software. Normalize the phosphorylated protein signal to the total protein signal.

Protocol 2: Cell Viability (IC50) Assay

This protocol is for determining the half-maximal inhibitory concentration (IC50) of **XA-E**.[\[1\]](#)[\[13\]](#)

- **Cell Seeding:** Seed 5,000 cells per well in a 96-well plate and allow them to adhere overnight.
- **Drug Treatment:** Prepare a serial dilution of **XA-E**. Treat the cells with a range of concentrations for 72 hours. Include a vehicle-only control.
- **Viability Measurement:** Add a cell viability reagent (e.g., CellTiter-Glo®) to each well according to the manufacturer's instructions.
- **Data Analysis:** Measure luminescence using a plate reader. Normalize the data to the untreated controls and fit a dose-response curve using appropriate software (e.g., GraphPad Prism) to determine the IC50 value.

Visualizations

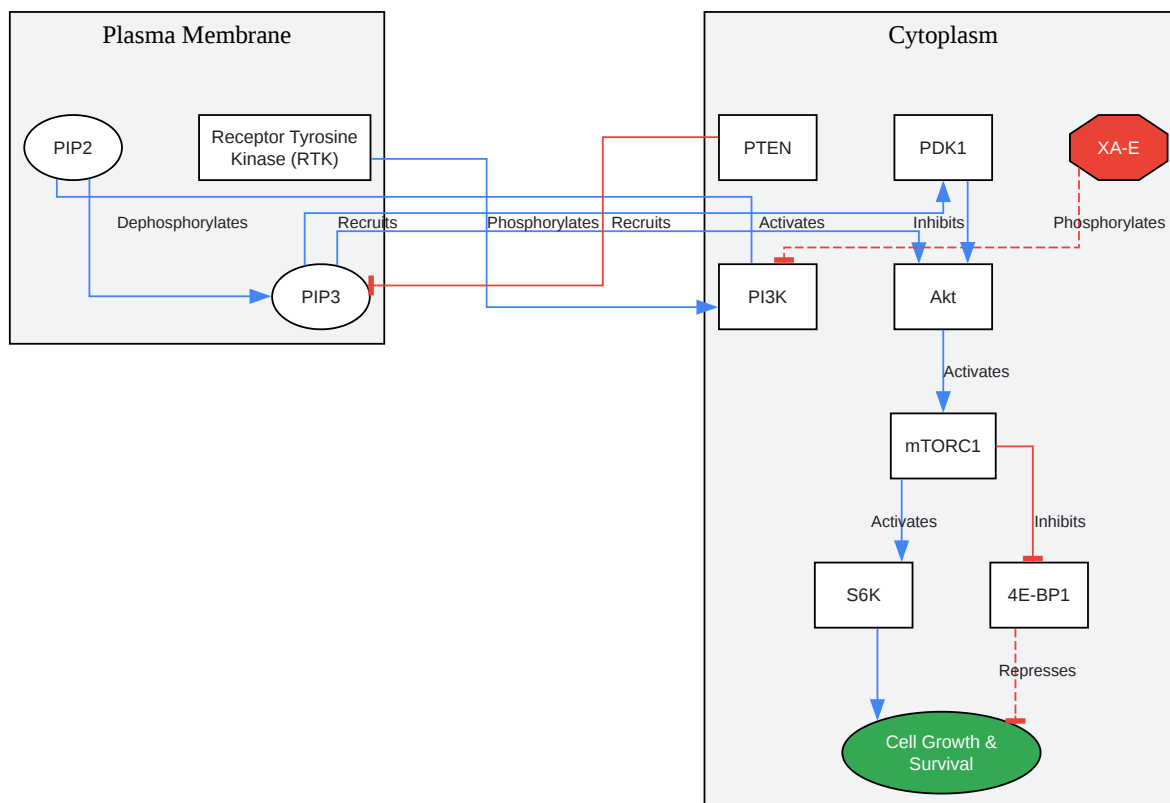

[Click to download full resolution via product page](#)

Caption: PI3K/Akt/mTOR signaling pathway with the inhibitory action of **XA-E**.

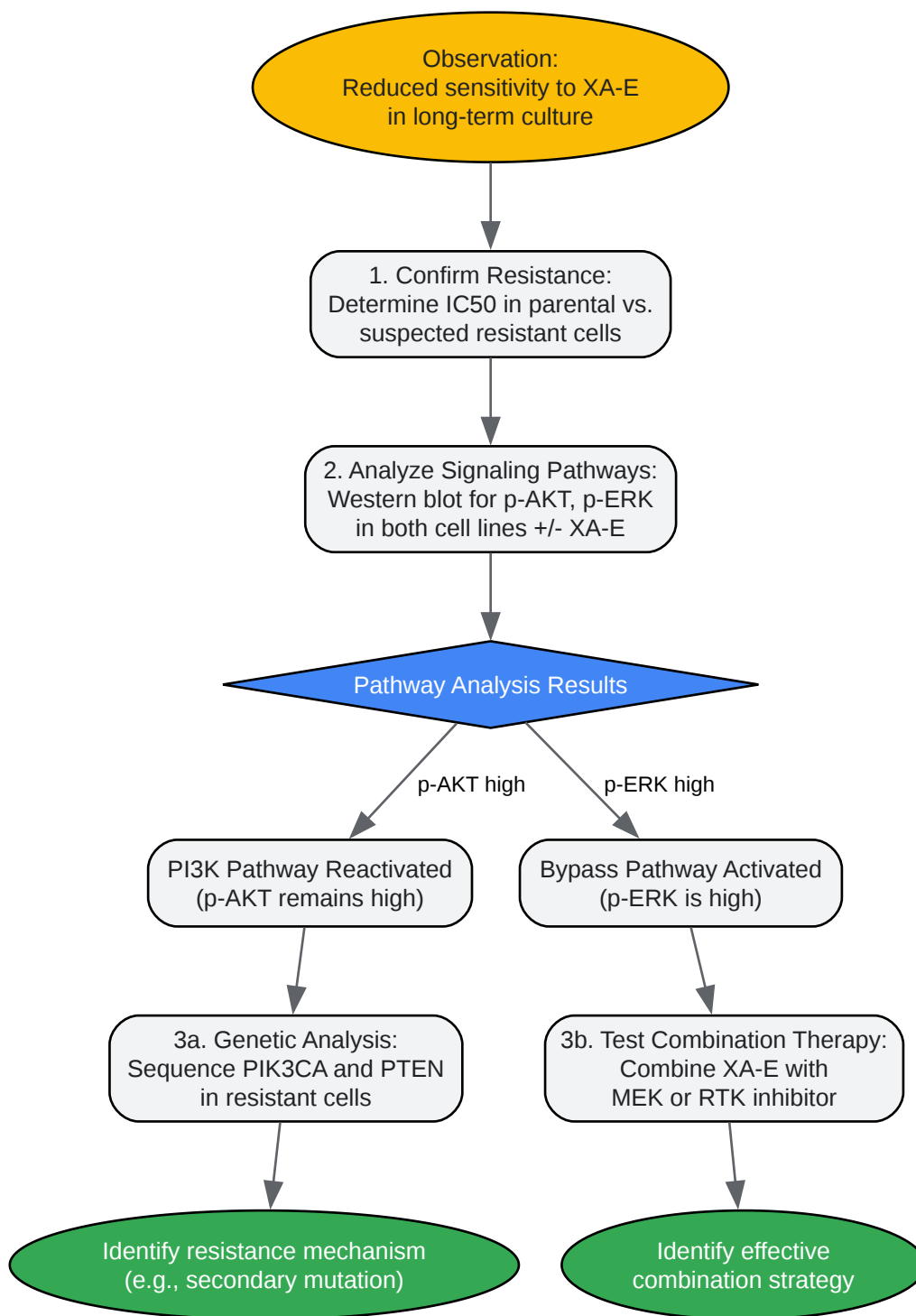

[Click to download full resolution via product page](#)

Caption: Experimental workflow for investigating **XA-E** resistance.

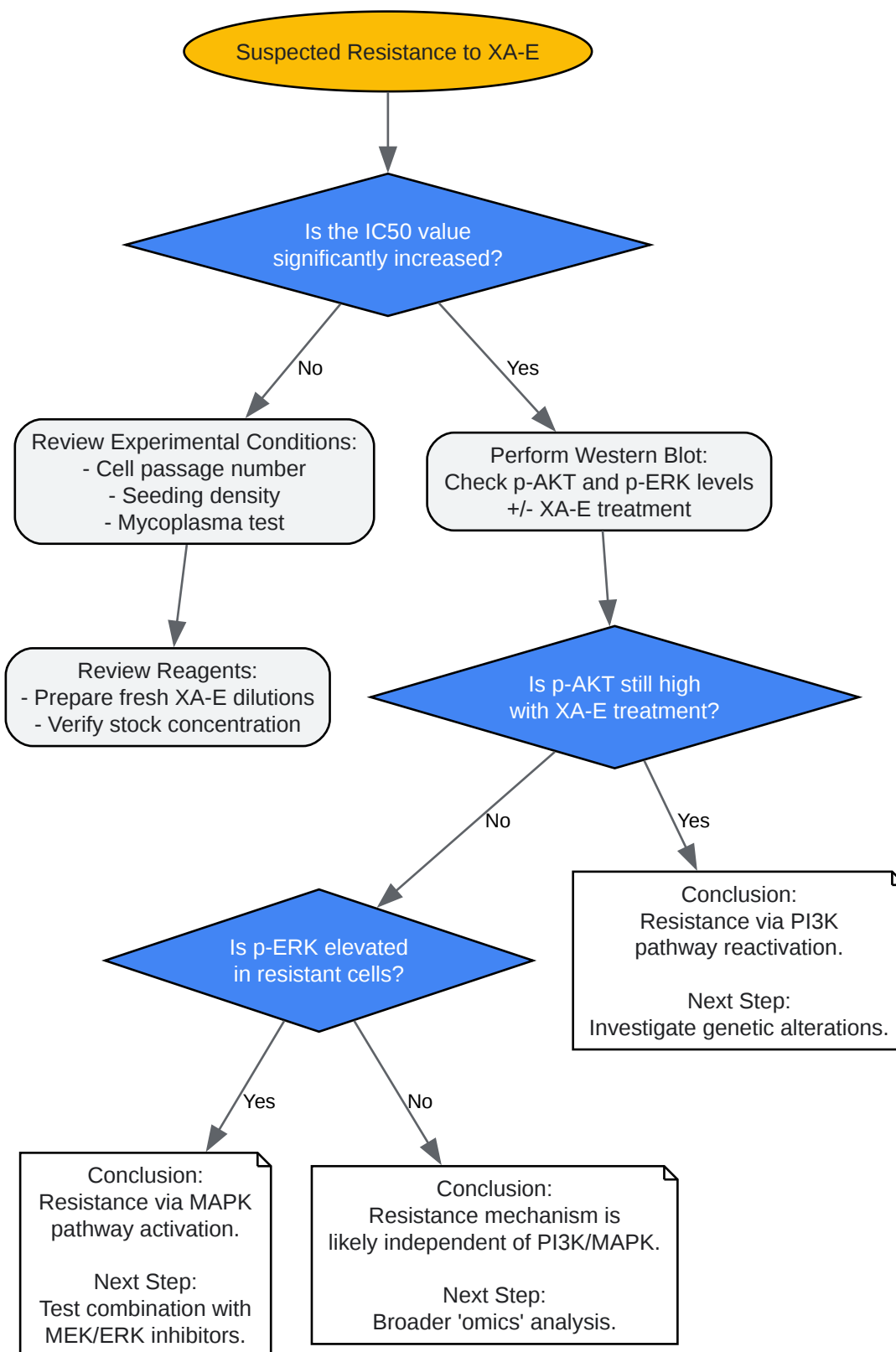

[Click to download full resolution via product page](#)

Need Custom Synthesis?

BenchChem offers custom synthesis for rare earth carbides and specific isotopic labeling.

Email: info@benchchem.com or [Request Quote Online](#).

References

- [1. benchchem.com \[benchchem.com\]](#)
- [2. PI3K/AKT/mTOR Signaling Pathway | Encyclopedia MDPI \[encyclopedia.pub\]](#)
- [3. benchchem.com \[benchchem.com\]](#)
- [4. Mechanisms of Resistance to PI3K Inhibitors in Cancer: Adaptive Responses, Drug Tolerance and Cellular Plasticity - PMC \[pmc.ncbi.nlm.nih.gov\]](#)
- [5. Molecular mechanisms of tumor resistance to PI3K-mTOR-targeted therapy - PMC \[pmc.ncbi.nlm.nih.gov\]](#)
- [6. mdpi.com \[mdpi.com\]](#)
- [7. onclive.com \[onclive.com\]](#)
- [8. Challenges for the clinical development of PI3K inhibitors: Strategies to improve their impact in solid tumors - PMC \[pmc.ncbi.nlm.nih.gov\]](#)
- [9. fiercebiotech.com \[fiercebiotech.com\]](#)
- [10. Frontiers | Activation of PI3K/AKT/mTOR Pathway Causes Drug Resistance in Breast Cancer \[frontiersin.org\]](#)
- [11. mdpi.com \[mdpi.com\]](#)
- [12. researchgate.net \[researchgate.net\]](#)
- [13. Measuring Cancer Drug Sensitivity and Resistance in Cultured Cells - PMC \[pmc.ncbi.nlm.nih.gov\]](#)
- [14. Drug-resistant Cell Lines—Crack the Survival Code of Cancer Cells and Overcome Treatment Barriers \[procellsystem.com\]](#)
- To cite this document: BenchChem. [XA-E Treatment Technical Support Center]. BenchChem, [2026]. [Online PDF]. Available at: [<https://www.benchchem.com/product/b12408668/docs#xa-e-treatment-technical-support-center>]

Disclaimer & Data Validity:

The information provided in this document is for Research Use Only (RUO) and is strictly not intended for diagnostic or therapeutic procedures. While BenchChem strives to provide accurate protocols, we make no warranties, express or implied, regarding the fitness of this product for every specific experimental setup.

Technical Support: The protocols provided are for reference purposes. Unsure if this reagent suits your experiment?

Need Industrial/Bulk Grade? [Request Custom Synthesis Quote](#)

BenchChem

Our mission is to be the trusted global source of essential and advanced chemicals, empowering scientists and researchers to drive progress in science and industry.

Contact

Address: 3281 E Guasti Rd
Ontario, CA 91761, United States
Phone: (601) 213-4426
Email: info@benchchem.com

[Contact our Ph.D. Support Team for a compatibility check](#)