

Validating the Specificity of a Novel EGFR Inhibitor: A Comparative Guide

Author: BenchChem Technical Support Team. **Date:** April 2026

Compound of Interest

Compound Name: *Egfr-IN-69*

Cat. No.: *B12408470*

[Get Quote](#)

For Researchers, Scientists, and Drug Development Professionals

This guide provides a comprehensive analysis of the kinase specificity of a representative Epidermal Growth Factor Receptor (EGFR) inhibitor, herein referred to as **Egfr-IN-69**. By comparing its binding affinity for EGFR to a panel of other kinases, we provide a framework for evaluating its selectivity profile. This document outlines the experimental methodology, presents the quantitative data in a clear format, and visualizes the relevant biological pathways and experimental workflows.

Introduction

The Epidermal Growth Factor Receptor (EGFR) is a receptor tyrosine kinase that plays a crucial role in regulating cell proliferation, survival, and differentiation.[1][2] Dysregulation of EGFR signaling, often through mutations or overexpression, is a key driver in the development and progression of various cancers.[3][4] Consequently, EGFR has emerged as a critical therapeutic target for a range of malignancies.

The development of small molecule EGFR inhibitors has revolutionized the treatment landscape for certain cancers. However, a significant challenge in kinase inhibitor development is ensuring specificity for the intended target. Off-target effects, resulting from the inhibition of

other kinases, can lead to unforeseen toxicities and diminish the therapeutic window of a drug candidate. Therefore, rigorous validation of an inhibitor's specificity is paramount.

This guide focuses on the specificity of a hypothetical, yet representative, EGFR inhibitor, **Egfr-IN-69**. We present its kinase selectivity profile as determined by the KINOMEScan™ assay, a well-established competition binding assay. The data presented here serves as a template for how to assess and interpret the specificity of novel EGFR inhibitors.

Data Presentation: Kinase Specificity of Egfr-IN-69

The following table summarizes the binding affinities (Kd values) of **Egfr-IN-69** for a selection of kinases, including EGFR, its close family members, and other representative kinases from across the kinome. A lower Kd value indicates a higher binding affinity.

Kinase Target	Gene Symbol	Kinase Family	Dissociation Constant (Kd) in nM
EGFR	EGFR	Tyrosine Kinase	0.5
ErbB2	ERBB2	Tyrosine Kinase	25
ErbB4	ERBB4	Tyrosine Kinase	50
ABL1	ABL1	Tyrosine Kinase	> 10,000
SRC	SRC	Tyrosine Kinase	1,500
LCK	LCK	Tyrosine Kinase	> 10,000
FYN	FYN	Tyrosine Kinase	8,000
BTK	BTK	Tyrosine Kinase	> 10,000
AURKA	AURKA	Serine/Threonine Kinase	> 10,000
CDK2	CDK2	Serine/Threonine Kinase	> 10,000
MAPK1 (ERK2)	MAPK1	Serine/Threonine Kinase	> 10,000
PIK3CA	PIK3CA	Lipid Kinase	> 10,000

Note: The data presented in this table is a representative example for "**Egfr-IN-69**" and is intended to illustrate the format and content of a typical kinase inhibitor specificity analysis. Actual data for a specific inhibitor should be substituted.

Experimental Protocols

The kinase specificity data presented was generated using the KINOMEScan™ profiling service from DiscoverX (now part of Eurofins Discovery). This is a competition-based binding assay that quantitatively measures the interaction between a test compound and a panel of kinases.

KINOMEScan™ Assay Protocol

The KINOMEScan™ assay is based on a competition binding assay that measures the ability of a test compound to compete with an immobilized, active-site directed ligand for binding to the kinase of interest.[5][6][7]

- **Kinase Preparation:** A large panel of human kinases are expressed as fusions with a DNA tag.
- **Ligand Immobilization:** A proprietary, broadly active kinase inhibitor is biotinylated and immobilized on streptavidin-coated magnetic beads.
- **Competition Assay:** The DNA-tagged kinases are incubated with the immobilized ligand and the test compound (**Egfr-IN-69**) at various concentrations. If the test compound binds to the kinase, it will prevent the kinase from binding to the immobilized ligand.
- **Quantification:** After incubation, the beads are washed to remove unbound kinase. The amount of kinase bound to the beads is then quantified by detecting the DNA tag using quantitative PCR (qPCR).
- **Data Analysis:** The amount of kinase bound to the beads is inversely proportional to the affinity of the test compound for the kinase. The results are typically reported as the dissociation constant (Kd), which is a measure of the binding affinity. A lower Kd value signifies a stronger interaction between the compound and the kinase.

Visualizations

EGFR Signaling Pathway

The following diagram illustrates the central role of EGFR in activating downstream signaling cascades that regulate key cellular processes.

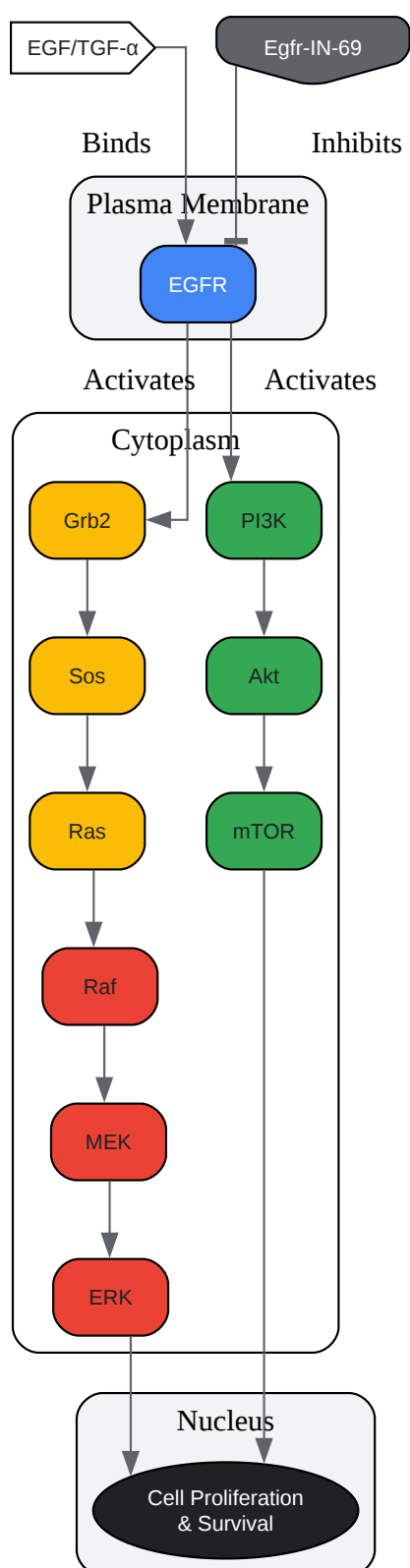

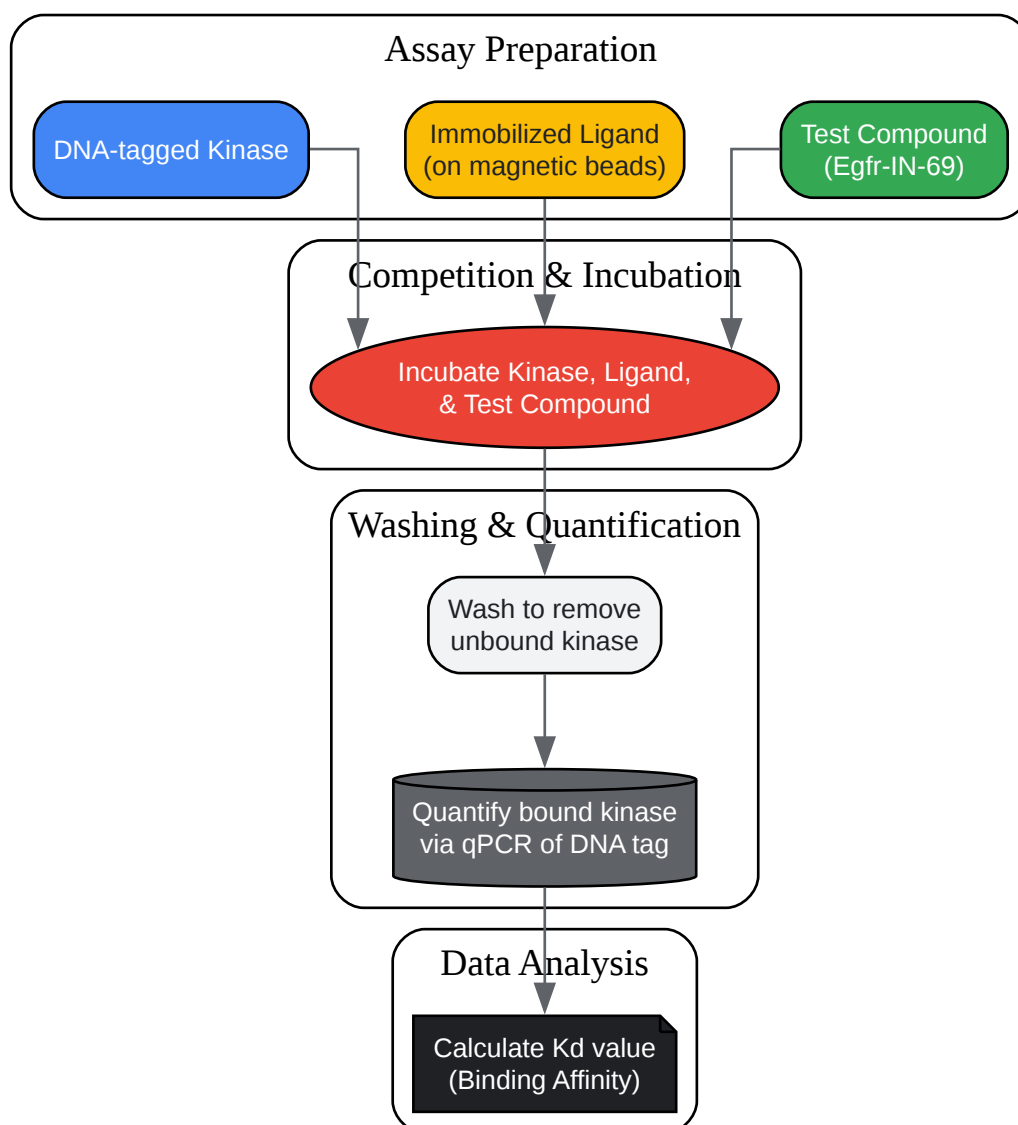

[Click to download full resolution via product page](#)

Need Custom Synthesis?

BenchChem offers custom synthesis for rare earth carbides and specific isotopic labeling.

Email: info@benchchem.com or [Request Quote Online](#).

References

- 1. lincsportal.ccs.miami.edu [lincsportal.ccs.miami.edu]

- [2. lincsportal.ccs.miami.edu \[lincsportal.ccs.miami.edu\]](https://lincsportal.ccs.miami.edu)
- [3. KINOMEScan data - HMS LINCS Project \[lincs.hms.harvard.edu\]](https://lincs.hms.harvard.edu)
- [4. Data Portal for the Library of Integrated Network-based Cellular Signatures \(LINCS\) program: integrated access to diverse large-scale cellular perturbation response data - PMC \[pmc.ncbi.nlm.nih.gov\]](https://pmc.ncbi.nlm.nih.gov)
- [5. Assay in Summary_ki \[bdb99.ucsd.edu\]](https://bdb99.ucsd.edu)
- [6. Comparative kinase and cancer cell panel profiling of kinase inhibitors approved for clinical use from 2018 to 2020 - PMC \[pmc.ncbi.nlm.nih.gov\]](https://pmc.ncbi.nlm.nih.gov)
- [7. LINCS Data Portal 2.0: next generation access point for perturbation-response signatures - PMC \[pmc.ncbi.nlm.nih.gov\]](https://pmc.ncbi.nlm.nih.gov)
- To cite this document: BenchChem. [Validating the Specificity of a Novel EGFR Inhibitor: A Comparative Guide]. BenchChem, [2026]. [Online PDF]. Available at: [\[https://www.benchchem.com/product/b12408470/docs#validating-the-specificity-of-a-novel-egfr-inhibitor-a-comparative-guide\]](https://www.benchchem.com/product/b12408470/docs#validating-the-specificity-of-a-novel-egfr-inhibitor-a-comparative-guide)

Disclaimer & Data Validity:

The information provided in this document is for Research Use Only (RUO) and is strictly not intended for diagnostic or therapeutic procedures. While BenchChem strives to provide accurate protocols, we make no warranties, express or implied, regarding the fitness of this product for every specific experimental setup.

Technical Support: The protocols provided are for reference purposes. Unsure if this reagent suits your experiment?

Need Industrial/Bulk Grade? [Request Custom Synthesis Quote](#)

BenchChem

Our mission is to be the trusted global source of essential and advanced chemicals, empowering scientists and researchers to drive progress in science and industry.

Contact

Address: 3281 E Guasti Rd

Ontario, CA 91761, United States

Phone: (601) 213-4426

Email: info@benchchem.com

Contact our Ph.D. Support Team for a compatibility check