

# Structural Analysis of a Direct Factor Xa Inhibitor: A Technical Guide

**Author:** BenchChem Technical Support Team. **Date:** April 2026

## Compound of Interest

Compound Name:	XA-E
CAS No.:	132998-84-6
Cat. No.:	B12408668

[Get Quote](#)

Audience: Researchers, scientists, and drug development professionals.

Core Focus: This guide provides a comprehensive overview of the structural analysis, mechanism of action, and experimental evaluation of a representative direct Factor Xa (FXa) inhibitor, Rivaroxaban. While the specific compound "XA-E" is not defined in scientific literature, Rivaroxaban serves as an exemplary model for this class of anticoagulants.

## Introduction

Rivaroxaban is an orally active, direct inhibitor of Factor Xa, a critical enzyme in the coagulation cascade.<sup>[1][2]</sup> Its development marked a significant advancement in anticoagulant therapy, offering a more predictable pharmacokinetic and pharmacodynamic profile compared to traditional anticoagulants like warfarin.<sup>[1][3]</sup> This document details the structural features, mechanism of action, synthesis, and analytical protocols relevant to Rivaroxaban, providing a framework for the analysis of similar FXa inhibitors.

## Structural and Physicochemical Properties

Rivaroxaban is a monocarboxylic acid amide with a complex heterocyclic structure.[4] Its key structural components include a 5-chlorothiophene-2-carboxylic acid moiety, an oxazolidinone ring, and a morpholin-3-one group.[4][5] The (S)-configuration of the oxazolidinone ring is crucial for its biological activity.

Table 1: Physicochemical and Pharmacokinetic Properties of Rivaroxaban

Property	Value	Reference
Molecular Formula	C <sub>19</sub> H <sub>18</sub> ClN <sub>3</sub> O <sub>5</sub> S	[4]
Molar Mass	435.88 g/mol	[4]
Oral Bioavailability	80-100% (10 mg dose)	[6]
Time to Max Plasma Conc.	2-4 hours	[6]
Plasma Protein Binding	~92-95%	[6]
Metabolism	Hepatic (CYP3A4/5, CYP2J2)	[3][7]
Elimination Half-life	5-9 hours (younger adults)	[8]

## Mechanism of Action

Rivaroxaban functions as a selective, direct inhibitor of both free Factor Xa and Factor Xa bound within the prothrombinase complex.[1][9] By binding to the active site of FXa, it blocks the conversion of prothrombin to thrombin, thereby inhibiting the final common pathway of the coagulation cascade and preventing fibrin clot formation.[2][3] Unlike indirect inhibitors, its action does not require a cofactor like antithrombin.[6]

## Signaling Pathway: The Coagulation Cascade

The diagram below illustrates the intrinsic and extrinsic pathways of the coagulation cascade, highlighting the central role of Factor Xa and the point of inhibition by Rivaroxaban.

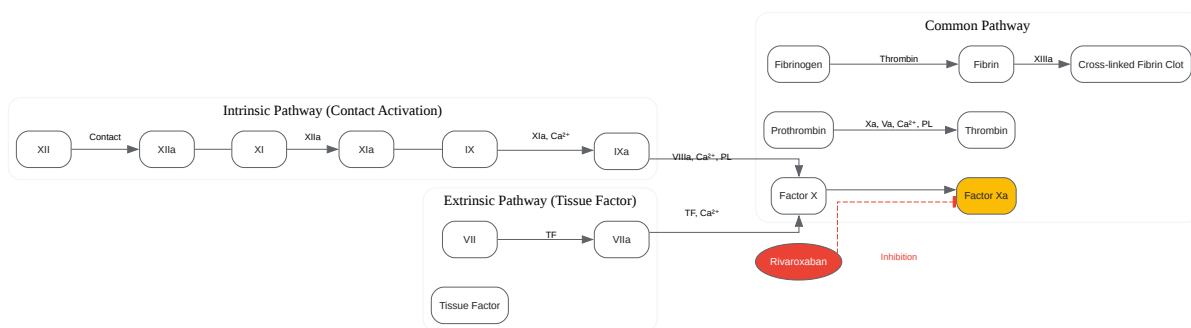

[Click to download full resolution via product page](#)

Caption: Inhibition of Factor Xa by Rivaroxaban in the coagulation cascade.

## Quantitative Analysis of Biological Activity

The inhibitory potency of Rivaroxaban has been quantified through various in vitro assays. These studies demonstrate its high affinity and selectivity for Factor Xa.

Table 2: In Vitro Inhibitory Activity of Rivaroxaban

Parameter	Target	Value	Reference
K <sub>i</sub> (Inhibition Constant)	Human Factor Xa	0.4 ± 0.02 nM	[6]
IC <sub>50</sub> (Prothrombinase Activity)	Prothrombinase-bound FXa	2.1 ± 0.4 nM	[6][9]
IC <sub>50</sub> (Clot-associated Activity)	Clot-associated FXa	75 nM	[6][9]
IC <sub>50</sub> (Endogenous FXa)	Endogenous FXa in human plasma	21 ± 1 nM	[6]
Selectivity	>10,000-fold vs. other serine proteases	[2][9]	

## Synthesis and Structural Elucidation Workflow

The synthesis of Rivaroxaban is a multi-step process, with a key challenge being the stereospecific construction of the oxazolidinone ring.[5][10] The general workflow for the development and analysis of a compound like Rivaroxaban involves synthesis, purification, and comprehensive structural characterization.

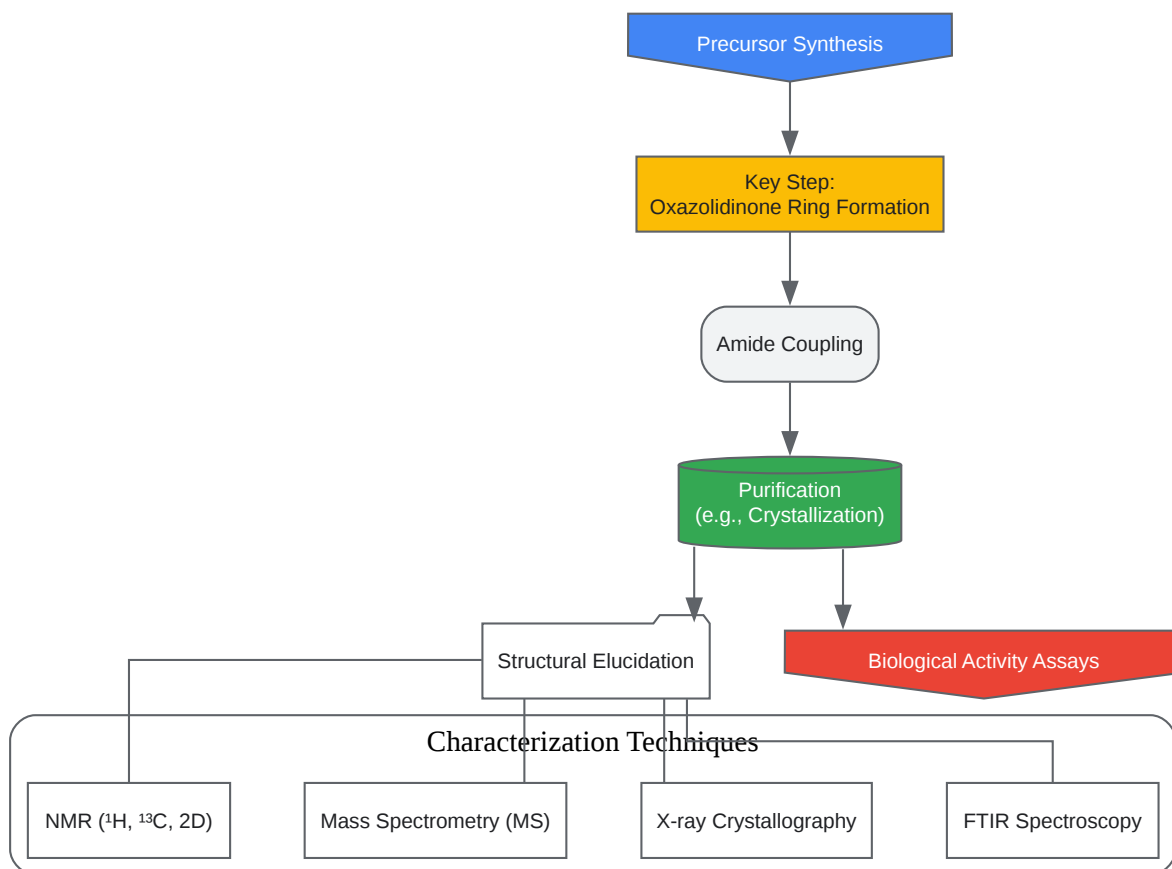

[Click to download full resolution via product page](#)

Caption: General workflow for the synthesis and structural analysis of Rivaroxaban.

## Experimental Protocols

### Synthesis of Rivaroxaban (Conceptual Outline)

A common synthetic strategy involves the copper-catalyzed construction of the N-aryloxazolidinone core.<sup>[10]</sup>

- Preparation of the Oxazolidinone Core: A key intermediate, 4-{4-[(5S)-5-(aminomethyl)-2-oxo-1,3-oxazolidin-3-yl]phenyl}morpholin-3-one, is synthesized. This often starts from a

chiral precursor to establish the correct stereochemistry.[11]

- Preparation of the Acid Chloride: 5-chlorothiophene-2-carboxylic acid is converted to its more reactive acid chloride derivative using a reagent like thionyl chloride.[11]
- Amide Coupling: The oxazolidinone intermediate is coupled with 5-chlorothiophene-2-carbonyl chloride in the presence of a base to form the final amide bond, yielding Rivaroxaban.[11]
- Purification: The crude product is purified by recrystallization from a suitable solvent, such as acetic acid, to obtain the final compound with high purity.[11]

## NMR Spectroscopy for Structural Characterization

NMR is a primary tool for the structural elucidation of Rivaroxaban and its metabolites.[7]

- Sample Preparation: Dissolve approximately 5-10 mg of the purified compound in a suitable deuterated solvent (e.g., DMSO-d<sub>6</sub>).
- 1D NMR Acquisition:
  - <sup>1</sup>H NMR: Acquire proton spectra to identify the number, chemical environment, and coupling of protons. Typical parameters include a 30° pulse, a relaxation delay of 2 seconds, and an acquisition time of ~3 seconds.[7]
  - <sup>13</sup>C NMR: Acquire carbon spectra to determine the carbon skeleton. A larger number of scans (e.g., 1024-4096) is typically required due to the lower natural abundance of <sup>13</sup>C.[7]
- 2D NMR Acquisition:
  - COSY (Correlation Spectroscopy): To establish proton-proton spin coupling networks.[7]
  - HSQC/HMQC (Heteronuclear Single Quantum Coherence/Multiple Quantum Coherence): To correlate protons with their directly attached carbons.
  - HMBC (Heteronuclear Multiple Bond Correlation): To identify long-range (2-3 bond) correlations between protons and carbons, which is crucial for assembling the molecular fragments.

- **Data Analysis:** Integrate and analyze the spectra to assign all proton and carbon signals, confirming the chemical structure of the compound.

## Factor Xa Inhibition Assay (In Vitro)

This protocol outlines a method to determine the inhibitory potency ( $IC_{50}$ ) of a test compound against human Factor Xa.

- **Reagents and Materials:** Purified human Factor Xa, a chromogenic FXa substrate (e.g., S-2222), Tris-HCl buffer, and the test compound (Rivaroxaban).
- **Assay Procedure:**
  - Prepare a series of dilutions of the test compound in the assay buffer.
  - In a 96-well plate, add the test compound dilutions, purified human Factor Xa, and buffer.
  - Incubate the mixture for a predetermined time (e.g., 15 minutes) at 37°C to allow for inhibitor binding.
  - Initiate the reaction by adding the chromogenic substrate.
  - Monitor the rate of substrate hydrolysis by measuring the change in absorbance at 405 nm over time using a microplate reader.
- **Data Analysis:**
  - Calculate the rate of reaction for each inhibitor concentration.
  - Plot the percent inhibition versus the logarithm of the inhibitor concentration.
  - Fit the data to a four-parameter logistic equation to determine the  $IC_{50}$  value.

## Logical Relationship of Rivaroxaban's Therapeutic Effect

The clinical utility of Rivaroxaban is a direct consequence of its specific biochemical interaction, leading to a systemic anticoagulant effect.

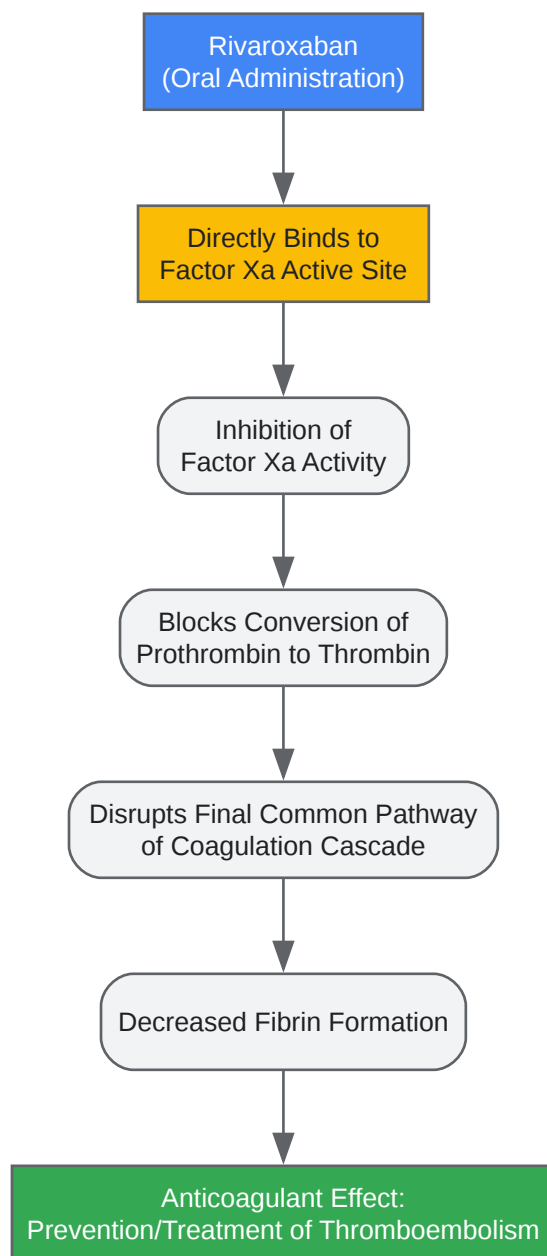

[Click to download full resolution via product page](#)

Caption: Logical flow from drug administration to therapeutic outcome.

## Conclusion

The structural analysis of Rivaroxaban reveals a highly optimized molecule designed for potent and selective inhibition of Factor Xa. Its well-defined structure-activity relationship, predictable pharmacokinetics, and oral bioavailability have established it as a cornerstone of modern

anticoagulant therapy. The methodologies and data presented in this guide provide a robust framework for the research and development of novel direct FXa inhibitors.

### Need Custom Synthesis?

BenchChem offers custom synthesis for rare earth carbides and specific isotopic labeling.

Email: [info@benchchem.com](mailto:info@benchchem.com) or [Request Quote Online](#).

## References

- [1. Rivaroxaban - Wikipedia \[en.wikipedia.org\]](#)
- [2. ahajournals.org \[ahajournals.org\]](#)
- [3. What is the mechanism of Rivaroxaban? \[synapse.patsnap.com\]](#)
- [4. Rivaroxaban | C19H18ClN3O5S | CID 9875401 - PubChem \[pubchem.ncbi.nlm.nih.gov\]](#)
- [5. pubs.acs.org \[pubs.acs.org\]](#)
- [6. Clinical Pharmacokinetic and Pharmacodynamic Profile of Rivaroxaban - PMC \[pmc.ncbi.nlm.nih.gov\]](#)
- [7. benchchem.com \[benchchem.com\]](#)
- [8. Exploring the Efficacy and Safety of Factor Xa Inhibitors in Anticoagulation Therapy: A Comprehensive Review of Current Research and Clinical Applications | ClinicSearch \[clinicsearchonline.org\]](#)
- [9. XARELTO - Mechanism of Action \[jnjmedicalconnect.com\]](#)
- [10. Thieme E-Journals - Synfacts / Abstract \[thieme-connect.com\]](#)
- [11. WO2016030669A1 - Process for the preparation of rivaroxaban - Google Patents \[patents.google.com\]](#)
- To cite this document: BenchChem. [Structural Analysis of a Direct Factor Xa Inhibitor: A Technical Guide]. BenchChem, [2026]. [Online PDF]. Available at: [\[https://www.benchchem.com/product/b12408668/docs#structural-analysis-of-a-direct-factor-xa-inhibitor-a-technical-guide\]](https://www.benchchem.com/product/b12408668/docs#structural-analysis-of-a-direct-factor-xa-inhibitor-a-technical-guide)

---

### Disclaimer & Data Validity:

The information provided in this document is for Research Use Only (RUO) and is strictly not intended for diagnostic or therapeutic procedures. While BenchChem strives to provide accurate protocols, we make no warranties, express or implied, regarding the fitness of this product for every specific experimental setup.

**Technical Support:** The protocols provided are for reference purposes. Unsure if this reagent suits your experiment?

**Need Industrial/Bulk Grade?** [Request Custom Synthesis Quote](#)

## BenchChem

Our mission is to be the trusted global source of essential and advanced chemicals, empowering scientists and researchers to drive progress in science and industry.

### Contact

Address: 3281 E Guasti Rd  
Ontario, CA 91761, United States  
Phone: (601) 213-4426  
Email: [info@benchchem.com](mailto:info@benchchem.com)

[Contact our Ph.D. Support Team for a compatibility check](#)