

Application Note: Analytical Methods for the Quantification of ZM514

Author: BenchChem Technical Support Team. **Date:** April 2026

Compound of Interest

Compound Name: ZM514
Cat. No.: B12408127

[Get Quote](#)

Disclaimer: As of the current date, "ZM514" is not a publicly documented or recognized compound in scientific literature. The following application note is a representative example created for a hypothetical small molecule, presumed to be a tyrosine kinase inhibitor, to demonstrate standard analytical methodologies. The protocols, data, and pathways are illustrative and should be adapted and validated for any specific compound.

Introduction

ZM514 is a hypothetical, potent, and selective small molecule inhibitor of the Epidermal Growth Factor Receptor (EGFR) tyrosine kinase. Accurate and precise quantification of **ZM514** in both bulk substance and biological matrices is critical for quality control, pharmacokinetic (PK), and pharmacodynamic (PD) studies during drug development. This document details two robust analytical methods for the quantification of **ZM514**: High-Performance Liquid Chromatography with Ultraviolet detection (HPLC-UV) for bulk substance and process intermediates, and Liquid Chromatography with Tandem Mass Spectrometry (LC-MS/MS) for sensitive quantification in plasma.

Method 1: Quantification of ZM514 by HPLC-UV

This method is suitable for determining the purity and concentration of **ZM514** in active pharmaceutical ingredient (API) batches and formulation development.

Experimental Protocol

1. Materials and Reagents:

- **ZM514** Reference Standard (Hypothetical)
- Acetonitrile (ACN), HPLC Grade
- Methanol (MeOH), HPLC Grade
- Formic Acid (FA), LC-MS Grade
- Ultrapure Water (18.2 MΩ·cm)

2. Standard and Sample Preparation:

- Stock Solution (1 mg/mL): Accurately weigh 10 mg of **ZM514** reference standard and dissolve in 10 mL of 50:50 ACN:Water.
- Calibration Standards: Perform serial dilutions of the stock solution with 50:50 ACN:Water to prepare calibration standards ranging from 1 µg/mL to 200 µg/mL.
- Quality Control (QC) Samples: Prepare QC samples at three concentrations (e.g., 5, 50, and 150 µg/mL) from a separate stock solution.
- Test Samples: Dissolve the test substance in 50:50 ACN:Water to an expected concentration within the calibration range.

3. HPLC-UV Instrument Conditions:

- Column: C18 reverse-phase column (e.g., 4.6 x 150 mm, 5 µm)
- Mobile Phase A: 0.1% Formic Acid in Water
- Mobile Phase B: 0.1% Formic Acid in Acetonitrile
- Gradient: 30% B to 95% B over 8 minutes, hold at 95% B for 2 minutes, return to 30% B for 2 minutes.
- Flow Rate: 1.0 mL/min
- Injection Volume: 10 µL
- Column Temperature: 35°C
- UV Detection: 254 nm

Data Presentation

The concentration of **ZM514** is determined by constructing a linear regression curve from the peak areas of the calibration standards.

Table 1: Representative HPLC-UV Calibration Curve Data for **ZM514**

Standard Concentration (µg/mL)	Peak Area (mAU*s)
1.0	15,340
5.0	76,550
20.0	308,100
50.0	771,200
100.0	1,545,000
200.0	3,098,500
Linearity (R ²)	> 0.999

Method 2: Quantification of **ZM514** in Human Plasma by LC-MS/MS

This method provides high sensitivity and selectivity required for pharmacokinetic analysis of **ZM514** in biological samples.

Experimental Protocol

1. Sample Preparation: Protein Precipitation

- Pipette 50 µL of plasma sample (standard, QC, or unknown) into a 1.5 mL microcentrifuge tube.
- Add 10 µL of Internal Standard (IS) working solution (e.g., a stable isotope-labeled **ZM514**, 100 ng/mL).
- Add 200 µL of ice-cold acetonitrile containing 0.1% formic acid to precipitate proteins.
- Vortex for 1 minute.
- Centrifuge at 14,000 x g for 10 minutes at 4°C.
- Transfer 150 µL of the supernatant to an HPLC vial for analysis.

2. LC-MS/MS Instrument Conditions:

- LC System: UPLC/UHPLC system
- Column: C18 reverse-phase column (e.g., 2.1 x 50 mm, 1.8 μ m)
- Mobile Phase A: 0.1% Formic Acid in Water
- Mobile Phase B: 0.1% Formic Acid in Acetonitrile
- Gradient: 10% B to 90% B over 3 minutes, hold and wash.
- Flow Rate: 0.4 mL/min
- Injection Volume: 5 μ L
- Mass Spectrometer: Triple quadrupole mass spectrometer
- Ionization Mode: Electrospray Ionization (ESI), Positive
- MRM Transitions (Hypothetical):
- **ZM514**: Q1: 450.2 m/z \rightarrow Q3: 320.1 m/z
- Internal Standard (IS): Q1: 456.2 m/z \rightarrow Q3: 326.1 m/z

Data Presentation

The method is validated for linearity, accuracy, precision, and sensitivity. The lower limit of quantification (LLOQ) is typically established.

Table 2: Summary of a Hypothetical Pharmacokinetic Study of **ZM514** in Human Plasma

Time Point (hours)	Mean Plasma Concentration (ng/mL)	Standard Deviation (ng/mL)
0 (Pre-dose)	Below LLOQ	-
0.5	85.6	12.3
1.0 (Cmax)	152.4	25.1
2.0	110.8	18.9
4.0	65.2	9.8
8.0	28.1	5.4
12.0	12.5	2.1
24.0	3.7	1.0

Visualizations

Hypothetical Signaling Pathway

The diagram below illustrates the proposed mechanism of action for **ZM514** as an inhibitor of the EGFR signaling pathway, which is commonly implicated in cell proliferation and survival.

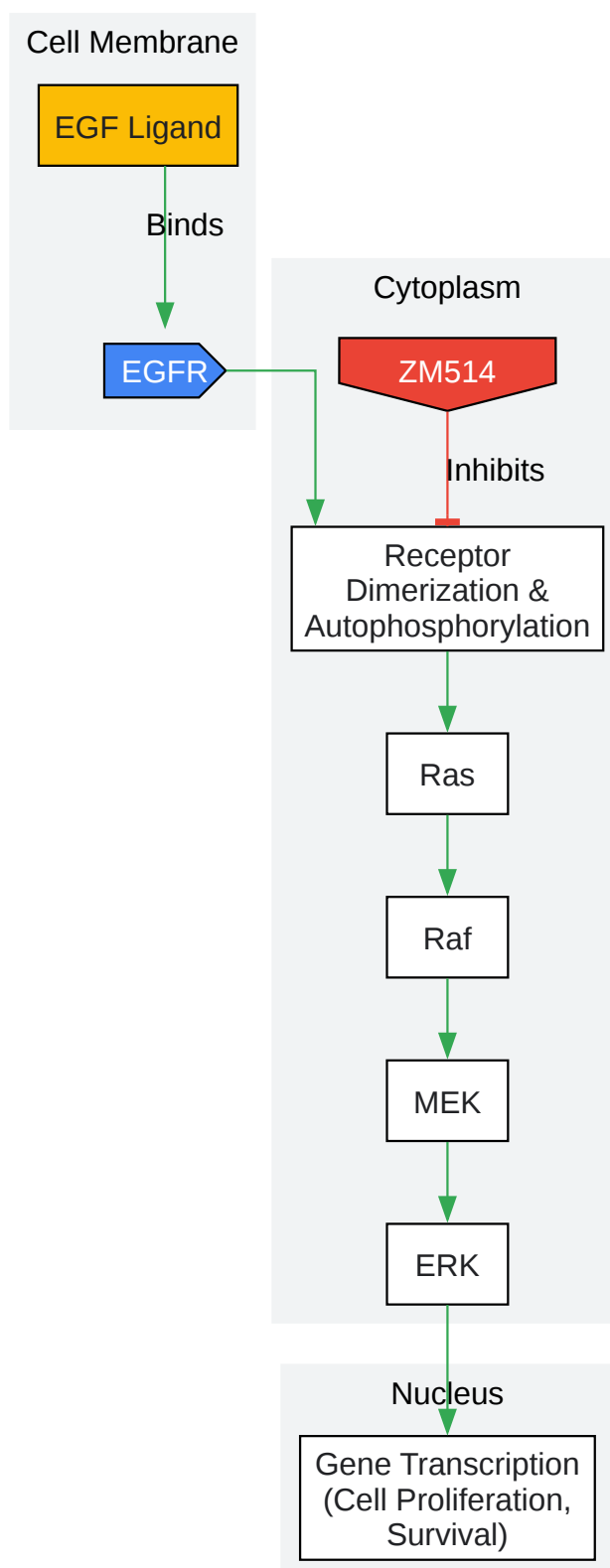

[Click to download full resolution via product page](#)

Caption: Hypothetical EGFR signaling pathway inhibited by **ZM514**.

LC-MS/MS Experimental Workflow

The following diagram outlines the major steps involved in the quantification of **ZM514** from plasma samples using the LC-MS/MS protocol.

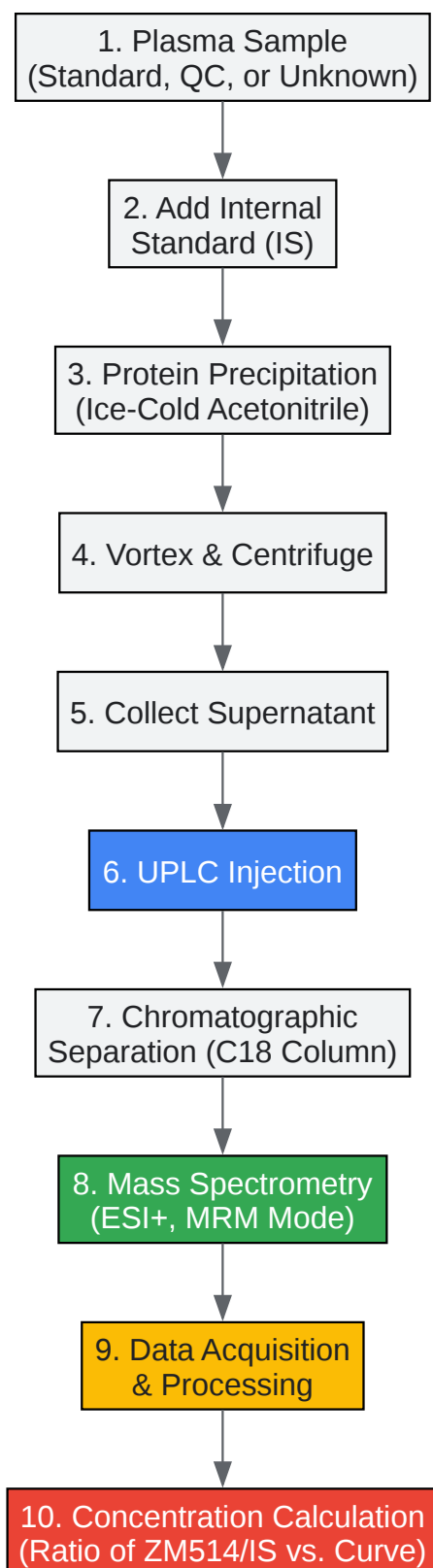

[Click to download full resolution via product page](#)

Caption: Workflow for **ZM514** quantification in plasma by LC-MS/MS.

- To cite this document: BenchChem. [Application Note: Analytical Methods for the Quantification of ZM514]. BenchChem, [2026]. [Online PDF]. Available at: [<https://www.benchchem.com/product/b12408127/docs#application-note-analytical-methods-for-the-quantification-of-zm514>]

Disclaimer & Data Validity:

The information provided in this document is for Research Use Only (RUO) and is strictly not intended for diagnostic or therapeutic procedures. While BenchChem strives to provide accurate protocols, we make no warranties, express or implied, regarding the fitness of this product for every specific experimental setup.

Technical Support: The protocols provided are for reference purposes. Unsure if this reagent suits your experiment?

Need Industrial/Bulk Grade? [Request Custom Synthesis Quote](#)

BenchChem

Our mission is to be the trusted global source of essential and advanced chemicals, empowering scientists and researchers to drive progress in science and industry.

Contact

Address: 3281 E Guasti Rd
Ontario, CA 91761, United States
Phone: (601) 213-4426
Email: info@benchchem.com

[Contact our Ph.D. Support Team for a compatibility check](#)