

Technical Support Center: HMBR Performance and Sludge Retention Time (SRT)

Author: BenchChem Technical Support Team. **Date:** April 2026

Compound of Interest

Compound Name: HMBR
Cat. No.: B12407879

[Get Quote](#)

This guide provides researchers, scientists, and drug development professionals with detailed troubleshooting information, frequently asked questions, and experimental protocols regarding the impact of Sludge Retention Time (SRT) on the performance of Hybrid Membrane Bioreactors (**HMBRs**).

Troubleshooting Guide

This section addresses specific issues you may encounter during your **HMBR** experiments related to SRT.

Problem: Rapid Increase in Transmembrane Pressure (TMP) and Severe Membrane Fouling

Q: My **HMBR** is experiencing a rapid rise in TMP, indicating significant membrane fouling. How can I troubleshoot this based on my SRT setting?

A: A rapid increase in TMP is a common issue in **HMBR** operation and is strongly linked to SRT. The relationship is not always linear, as both very short and very long SRTs can accelerate fouling.

Possible Causes & Recommended Actions:

- Cause 1: SRT is Too Short (e.g., < 10 days)
 - Why it happens: At very short SRTs, the biomass may not be mature enough to form stable flocs. This can lead to an increase in fine colloidal particles and higher concentrations of soluble microbial products (SMP), which are known to cause pore blocking and increase membrane resistance. Shortening SRT from 10 to 2 days has been shown to increase membrane fouling tenfold.[1]
 - Recommended Actions:
 - Verify SRT Calculation: Double-check your sludge wasting calculations to ensure you are maintaining the target SRT.
 - Gradually Increase SRT: Incrementally increase the SRT to a moderate level (e.g., 20-30 days). This allows for the development of a more stable microbial community and better floc structure.
 - Monitor Sludge Properties: Measure particle size distribution and SMP concentrations to confirm if a short SRT is the root cause.
- Cause 2: SRT is Too Long (e.g., > 60 days)
 - Why it happens: While longer SRTs can enhance the removal of certain pollutants, they also lead to a significant increase in Mixed Liquor Suspended Solids (MLSS) concentration.[1][2] This higher solid content increases the viscosity of the sludge and promotes the formation of a thicker, more resistant cake layer on the membrane surface. [1] Furthermore, at very long SRTs, an increase in extracellular polymeric substances (EPS) can occur, which are primary agents of membrane fouling.[3]
 - Recommended Actions:
 - Optimize SRT: Based on experimental data, an SRT of 30 days often provides an optimal balance, minimizing the production of soluble and loosely bound EPS, thereby reducing fouling and maximizing the membrane's operational cycle.[1][4][5]

- Increase Aeration/Scouring: If a long SRT is necessary for your experiment, ensure that membrane scouring via aeration is sufficient to control cake layer formation.
 - Implement Intermittent Permeation: Introduce relaxation periods (pausing permeate extraction) to allow air scouring to more effectively dislodge foulants from the membrane surface.
- Cause 3: High Production of Extracellular Polymeric Substances (EPS)
 - Why it happens: EPS are the main cause of membrane fouling.[1][5] SRT directly influences the microbial community and their metabolic activities, including EPS production. An SRT of 30 days has been shown to correlate with the lowest production of soluble EPS (S-EPS) and loosely bound EPS (LB-EPS).[1][4][5]
 - Recommended Actions:
 - Adjust SRT to 30 Days: This is often the most effective SRT for minimizing EPS-related fouling.[1]
 - Characterize EPS: Extract and quantify the different fractions of EPS (S-EPS, LB-EPS, and tightly bound EPS) to understand the nature of the fouling.
 - Consider Biofilm Carriers: The "hybrid" nature of **HMBR**, using both activated sludge and biofilm, is designed to help control membrane fouling by reducing EPS.[5] Ensure your biofilm carriers are functioning correctly and are not overloaded.

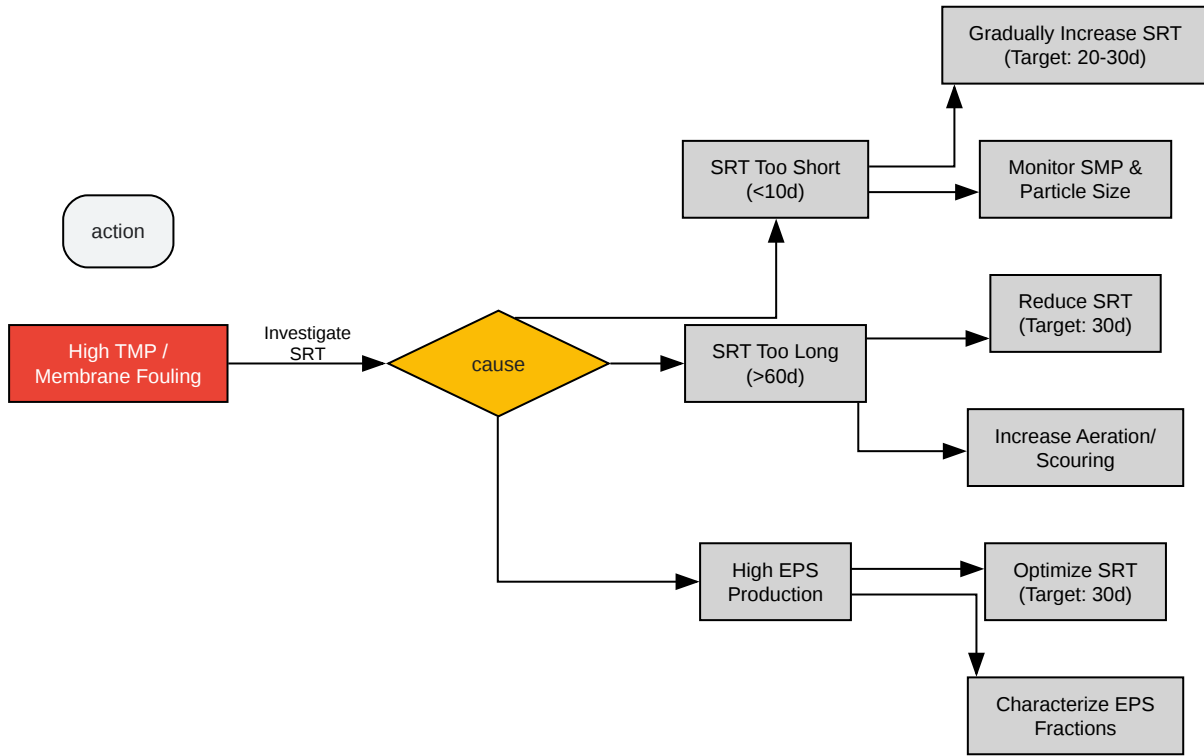

[Click to download full resolution via product page](#)

Caption: Troubleshooting workflow for high TMP and membrane fouling.

Problem: Poor Nutrient Removal

Q: My **HMBR** is showing poor removal efficiency for nitrogen and/or phosphorus. Could this be related to the SRT?

A: Yes, SRT is a critical parameter for controlling biological nutrient removal, as it determines whether the necessary microorganisms (like nitrifiers) can be retained and thrive in the system.

Possible Causes & Recommended Actions:

- Cause 1: Poor Nitrification (Low Ammonia Removal)

- Why it happens: Nitrifying bacteria are slow-growing. If the SRT is shorter than their regeneration time, they will be "washed out" of the system, leading to a failure in ammonia oxidation.[6] Generally, longer SRTs lead to better ammonia removal.[1]
- Recommended Actions:
 - Increase SRT: Ensure the SRT is sufficiently long to retain nitrifiers. An SRT of 20 days or longer typically shows high ammonia removal rates (>84%).[1][5] For complete nitrification, an SRT of 30 days or more is often recommended.[7]
 - Check Other Factors: Ensure that dissolved oxygen (DO) levels are adequate (> 2 mg/L) and that there are no inhibitory compounds in the influent.
- Cause 2: Poor Total Nitrogen (TN) Removal
 - Why it happens: TN removal requires both nitrification (aerobic) and denitrification (anoxic). While a long SRT helps nitrification, the optimal balance for both processes in an **HMBR** has been observed at a moderate SRT. The best TN removal (around 57.1%) was found at an SRT of 30 days.[1][5] At very long SRTs (e.g., 60 days), TN removal efficiency may decrease.[4]
 - Recommended Actions:
 - Target Optimal SRT: Adjust your SRT to 30 days for the best combined TN removal performance.[1]
 - Ensure Anoxic Conditions: Verify that your **HMBR** setup provides an adequate anoxic zone or anoxic phase for denitrification to occur.
- Cause 3: Poor Total Phosphorus (TP) Removal
 - Why it happens: Enhanced biological phosphorus removal (EBPR) relies on phosphorus-accumulating organisms (PAOs). The optimal SRT for these organisms can differ from that for nitrifiers. In one study, the best TP removal (up to 99.5%) was achieved at an SRT of 20 days.[1][5]
 - Recommended Actions:

- Adjust SRT: If TP removal is the primary goal, an SRT of around 20 days may be optimal.[\[1\]](#)
- Verify Anaerobic Zone: EBPR requires an initial anaerobic zone to encourage PAOs to release phosphorus. Ensure your reactor configuration and operation include this stage.

Frequently Asked Questions (FAQs)

Q1: What is the general relationship between SRT, MLSS, and sludge load in an **HMBR**? A1: SRT has a direct impact on the biomass concentration (MLSS) and the sludge load.

- Increasing SRT leads to a higher accumulation of solids, thus increasing the MLSS concentration.[\[1\]](#)
- As the MLSS (biomass) increases at a constant organic feed rate, the BOD sludge load (kg BOD per kg MLSS per day) decreases.[\[1\]](#) This relationship is crucial because the sludge load affects microbial characteristics, EPS production, and ultimately, membrane fouling.[\[1\]](#)

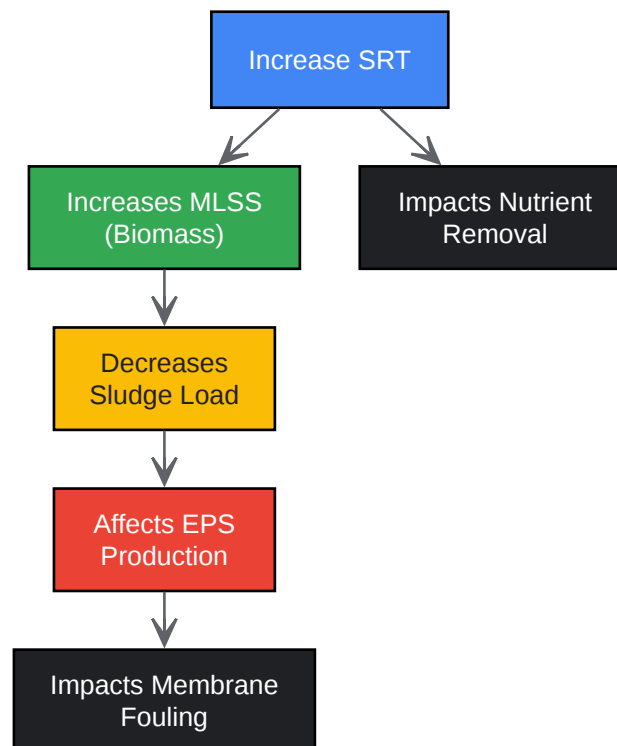

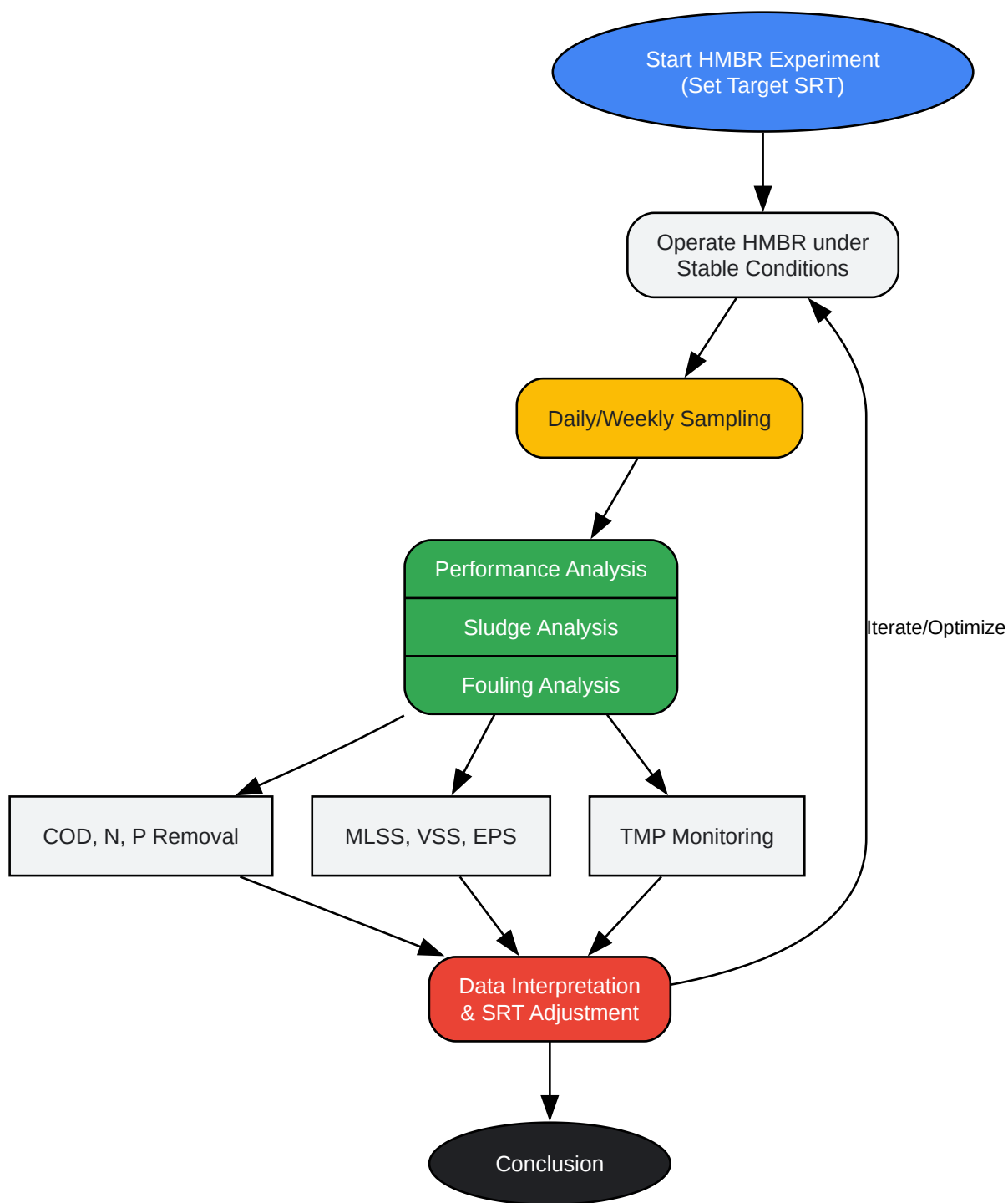

[Click to download full resolution via product page](#)

Need Custom Synthesis?

BenchChem offers custom synthesis for rare earth carbides and specific isotopic labeling.

Email: info@benchchem.com or [Request Quote Online](#).

References

- [1. Mechanism of HMBR in Reducing Membrane Fouling under Different SRT: Effect of Sludge Load on Microbial Properties - PMC \[pmc.ncbi.nlm.nih.gov\]](#)
- [2. researchgate.net \[researchgate.net\]](#)
- [3. mdpi.com \[mdpi.com\]](#)
- [4. mdpi.com \[mdpi.com\]](#)
- [5. researchgate.net \[researchgate.net\]](#)
- [6. envirosim.com \[envirosim.com\]](#)
- [7. publications.waset.org \[publications.waset.org\]](#)
- To cite this document: BenchChem. [Technical Support Center: HMBR Performance and Sludge Retention Time (SRT)]. BenchChem, [2026]. [Online PDF]. Available at: [\[https://www.benchchem.com/product/b12407879/docs#technical-support-center-hmbr-performance-and-sludge-retention-time-srt\]](https://www.benchchem.com/product/b12407879/docs#technical-support-center-hmbr-performance-and-sludge-retention-time-srt)

Disclaimer & Data Validity:

The information provided in this document is for Research Use Only (RUO) and is strictly not intended for diagnostic or therapeutic procedures. While BenchChem strives to provide accurate protocols, we make no warranties, express or implied, regarding the fitness of this product for every specific experimental setup.

Technical Support: The protocols provided are for reference purposes. Unsure if this reagent suits your experiment?

Need Industrial/Bulk Grade? [Request Custom Synthesis Quote](#)

BenchChem

Our mission is to be the trusted global source of essential and advanced chemicals, empowering scientists and researchers to drive progress in science and industry.

Contact

Address: 3281 E Guasti Rd

Ontario, CA 91761, United States

Phone: (601) 213-4426

Email: info@benchchem.com

[Contact our Ph.D. Support Team for a compatibility check](#)