

Minimizing batch-to-batch variability of IL-17 modulator 6

Author: BenchChem Technical Support Team. **Date:** April 2026

Compound of Interest

Compound Name: *IL-17 modulator 6*

Cat. No.: *B12407871*

[Get Quote](#)

Technical Support Center: IL-17 Modulator 6

This technical support center provides troubleshooting guidance and frequently asked questions (FAQs) to address potential issues with batch-to-batch variability of **IL-17 Modulator 6**, a small molecule inhibitor of the IL-17A/IL-17RA interaction.

Frequently Asked Questions (FAQs)

Q1: What is the mechanism of action for **IL-17 Modulator 6**?

A1: **IL-17 Modulator 6** is a synthetic small molecule designed to competitively inhibit the protein-protein interaction between the pro-inflammatory cytokine IL-17A and its receptor, IL-17RA.[1][2] By blocking this interaction, the modulator prevents the downstream signaling cascade that leads to the production of inflammatory mediators like chemokines and other cytokines.[3][4][5]

Q2: What are the most common sources of batch-to-batch variability with small molecule inhibitors like **IL-17 Modulator 6**?

A2: The most common sources of variability include differences in purity, the presence of residual solvents or byproducts from synthesis, variations in crystalline form (polymorphism), and degradation of the compound due to improper storage or handling. These factors can significantly impact the compound's solubility, stability, and ultimately, its biological activity in your experiments.

Q3: How should I properly store and handle **IL-17 Modulator 6** to ensure its stability?

A3: For optimal stability, **IL-17 Modulator 6** should be stored as a lyophilized powder at -20°C or -80°C, protected from light and moisture. For creating stock solutions, use an appropriate solvent as indicated on the datasheet (e.g., DMSO) and store at -80°C in small aliquots to avoid repeated freeze-thaw cycles. Before use, allow the vial to equilibrate to room temperature before opening to prevent condensation.

Q4: What quality control measures are recommended before using a new batch of **IL-17 Modulator 6**?

A4: It is highly recommended to perform your own quality control checks. Key analyses include verifying the compound's identity and purity, typically by High-Performance Liquid Chromatography (HPLC) and Liquid Chromatography-Mass Spectrometry (LC-MS). Assessing the compound's biological activity in a standardized functional assay is also crucial to confirm its potency.

Troubleshooting Guides

Issue 1: Decreased or Inconsistent Potency in Cell-Based Assays

You may observe a significant difference in the IC50 value or the maximal inhibition between different batches of **IL-17 Modulator 6**.

Potential Cause	Troubleshooting Step
Compound Purity and Integrity	<ol style="list-style-type: none">1. Verify Purity: Request the certificate of analysis (CofA) for each batch and compare the purity data. If possible, perform in-house HPLC analysis to confirm purity.2. Confirm Identity: Use LC-MS to verify the molecular weight of the compound.
Solubility Issues	<ol style="list-style-type: none">1. Visual Inspection: After dissolving, check the solution for any visible precipitates.2. Optimize Dissolution: Gently warm the solution (e.g., to 37°C) and vortex to ensure complete dissolution.3. Fresh Dilutions: Prepare fresh dilutions from the stock solution for each experiment.
Compound Degradation	<ol style="list-style-type: none">1. Storage Conditions: Confirm that the compound has been stored correctly (e.g., -80°C, protected from light).2. Avoid Freeze-Thaw Cycles: Use single-use aliquots of the stock solution.
Cell-Based Assay Variability	<ol style="list-style-type: none">1. Cell Passage Number: Ensure you are using cells within a consistent and low passage number range.2. Cell Health: Regularly check for mycoplasma contamination and ensure high cell viability before starting the assay.3. Reagent Consistency: Use the same batch of serum, media, and other critical reagents for all experiments you are comparing.

Issue 2: Unexpected Cytotoxicity or Off-Target Effects

You may notice increased cell death or other unexpected cellular responses that were not observed with previous batches.

Potential Cause	Troubleshooting Step
Presence of Impurities	<ol style="list-style-type: none">1. Analyze Purity Profile: Examine the HPLC or LC-MS chromatogram for the presence of additional peaks that may represent impurities from the synthesis process.2. Consult Supplier: Contact the supplier to inquire about any known impurities or changes in the synthesis protocol.
Residual Solvents	<ol style="list-style-type: none">1. Check CofA: The certificate of analysis should provide information on residual solvents. High concentrations of certain solvents can be toxic to cells.2. Solvent Control: Ensure you have a vehicle control (e.g., DMSO) in your experiment at the same final concentration as the compound-treated wells.
Compound Aggregation	<ol style="list-style-type: none">1. Solubility Check: Poorly soluble compounds can form aggregates that may be cytotoxic. Refer to the solubility troubleshooting steps in the previous section.

Data Presentation

Table 1: Example Quality Control Specifications for IL-17 Modulator 6

This table provides an example of acceptable quality control parameters for different batches of the modulator.

Parameter	Method	Specification	Batch A Result	Batch B Result
Appearance	Visual Inspection	White to off-white powder	Conforms	Conforms
Purity (by HPLC)	HPLC-UV	≥ 98%	99.2%	98.5%
Identity (by MS)	LC-MS (ESI+)	Matches expected M+H	Conforms	Conforms
Potency (IC50)	Cell-Based Assay	10 - 50 nM	25 nM	45 nM
Solubility in DMSO	Visual Inspection	≥ 10 mg/mL	Conforms	Conforms

Experimental Protocols

Key Experiment: IL-6 Secretion Inhibition Assay in HT-29 Cells

This protocol describes a functional cell-based assay to determine the potency (IC50) of **IL-17 Modulator 6** by measuring the inhibition of IL-17A-induced IL-6 secretion.

1. Cell Culture:

- Culture HT-29 (human colon adenocarcinoma) cells in McCoy's 5A medium supplemented with 10% Fetal Bovine Serum (FBS) and 1% Penicillin-Streptomycin.
- Maintain cells at 37°C in a humidified atmosphere with 5% CO₂.
- Use cells between passages 5 and 15 for the assay.

2. Assay Procedure:

- Seed HT-29 cells in a 96-well flat-bottom plate at a density of 2.5×10^4 cells per well and allow them to adhere overnight.

- Prepare a serial dilution of **IL-17 Modulator 6** in assay medium (McCoy's 5A with 2% FBS). A typical concentration range would be 1 μ M to 0.1 nM. Include a vehicle control (e.g., 0.1% DMSO).
- Pre-incubate the cells with the different concentrations of **IL-17 Modulator 6** for 1 hour at 37°C.
- Stimulate the cells by adding recombinant human IL-17A to a final concentration of 50 ng/mL. Include an unstimulated control group.
- Incubate the plate for 24 hours at 37°C.

3. Measurement of IL-6:

- After incubation, centrifuge the plate and collect the cell culture supernatants.
- Measure the concentration of IL-6 in the supernatants using a commercially available ELISA kit, following the manufacturer's instructions.

4. Data Analysis:

- Generate a dose-response curve by plotting the percentage of inhibition of IL-6 secretion against the logarithm of the modulator concentration.
- Calculate the IC50 value using a non-linear regression analysis (e.g., four-parameter logistic fit).

Mandatory Visualizations

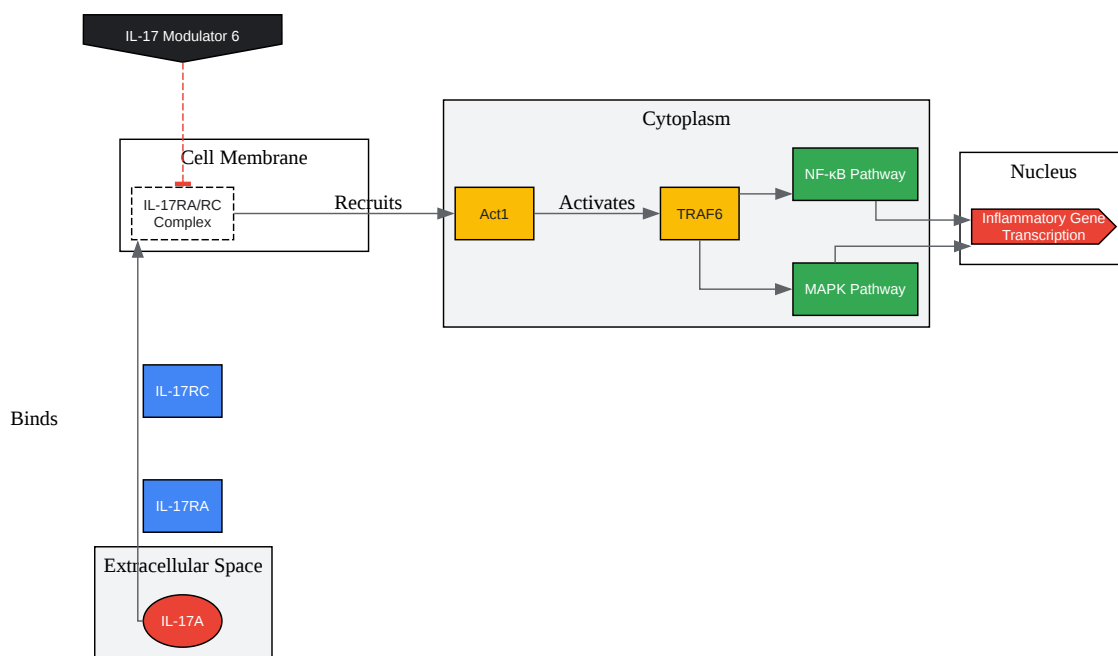

[Click to download full resolution via product page](#)

Caption: IL-17A signaling pathway and the inhibitory action of **IL-17 Modulator 6**.

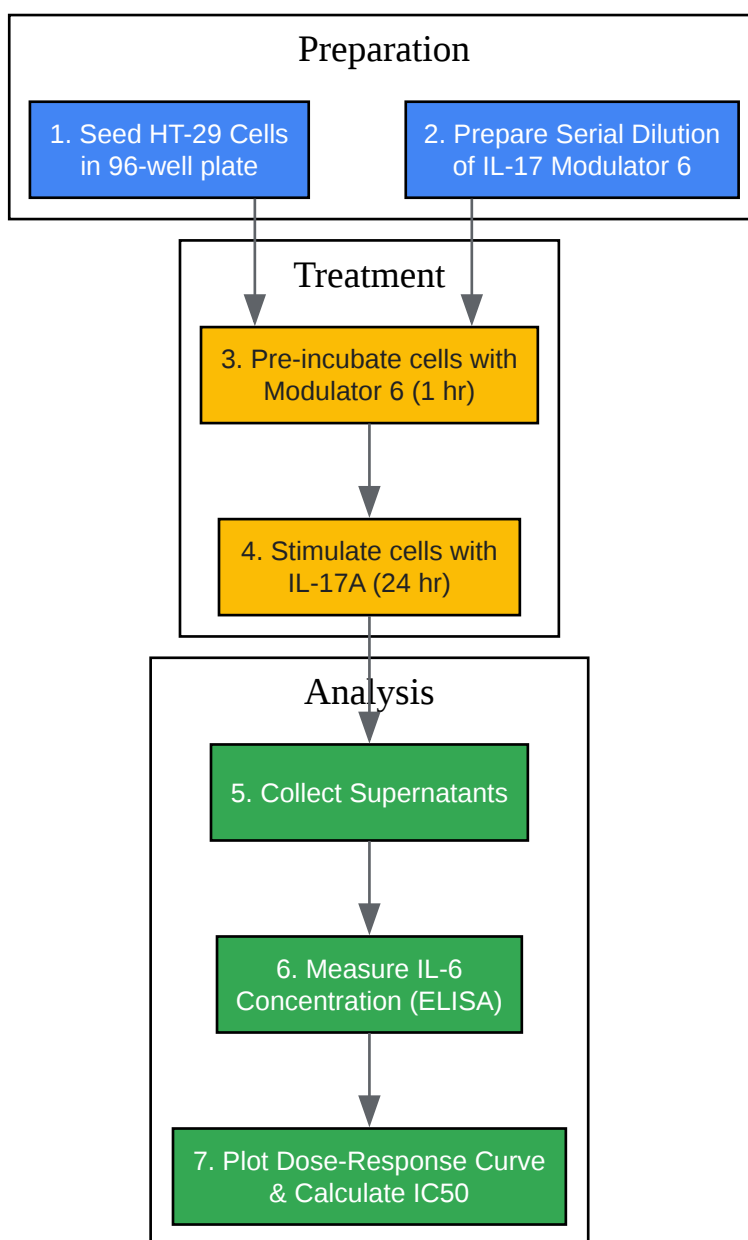

[Click to download full resolution via product page](#)

Need Custom Synthesis?

BenchChem offers custom synthesis for rare earth carbides and specific isotopic labeling.

Email: info@benchchem.com or [Request Quote Online](#).

References

- [1. tandfonline.com \[tandfonline.com\]](https://www.tandfonline.com)
- [2. Small molecule modulators of IL-17A/IL-17RA: a patent review \(2013-2021\) - PubMed \[pubmed.ncbi.nlm.nih.gov\]](https://pubmed.ncbi.nlm.nih.gov)
- [3. IL-17 Signaling Pathway: Implications in Immune Responses and Disease - Creative Proteomics \[cytokine.creative-proteomics.com\]](https://www.cytokine.creative-proteomics.com)
- [4. Interleukin 17 Family Cytokines: Signaling Mechanisms, Biological Activities, and Therapeutic Implications - PMC \[pmc.ncbi.nlm.nih.gov\]](https://pubmed.ncbi.nlm.nih.gov)
- [5. What are IL-17 modulators and how do they work? \[synapse.patsnap.com\]](https://www.synapse.patsnap.com)
- To cite this document: BenchChem. [Minimizing batch-to-batch variability of IL-17 modulator 6]. BenchChem, [2026]. [Online PDF]. Available at: [\[https://www.benchchem.com/product/b12407871/docs#minimizing-batch-to-batch-variability-of-il-17-modulator-6\]](https://www.benchchem.com/product/b12407871/docs#minimizing-batch-to-batch-variability-of-il-17-modulator-6)

Disclaimer & Data Validity:

The information provided in this document is for Research Use Only (RUO) and is strictly not intended for diagnostic or therapeutic procedures. While BenchChem strives to provide accurate protocols, we make no warranties, express or implied, regarding the fitness of this product for every specific experimental setup.

Technical Support: The protocols provided are for reference purposes. Unsure if this reagent suits your experiment?

Need Industrial/Bulk Grade? [Request Custom Synthesis Quote](#)

BenchChem

Our mission is to be the trusted global source of essential and advanced chemicals, empowering scientists and researchers to drive progress in science and industry.

Contact

Address: 3281 E Guasti Rd
Ontario, CA 91761, United States
Phone: (601) 213-4426
Email: info@benchchem.com

Contact our Ph.D. Support Team for a compatibility check