

"PCSK9 modulator-3" batch-to-batch variability testing

Author: BenchChem Technical Support Team. **Date:** April 2026

Compound of Interest

Compound Name: PCSK9 modulator-3

Cat. No.: B12406187

[Get Quote](#)

Technical Support Center: PCSK9 Modulator-3

This technical support center provides researchers, scientists, and drug development professionals with comprehensive troubleshooting guides and frequently asked questions (FAQs) for experiments involving **PCSK9 modulator-3**. The following resources are designed to help identify and resolve common issues, particularly those related to batch-to-batch variability, to ensure the consistency and reliability of your experimental results.

Frequently Asked Questions (FAQs)

Q1: What is **PCSK9 modulator-3** and what is its mechanism of action?

A1: **PCSK9 modulator-3**, also known as Compound 13, is a potent small molecule modulator of Proprotein Convertase Subtilisin/Kexin type 9 (PCSK9) with an EC50 value of 2.46 nM.^{[1][2]} Its primary mechanism of action is to inhibit the interaction between PCSK9 and the Low-Density Lipoprotein Receptor (LDLR).^{[3][4][5]} By preventing this interaction, the modulator blocks PCSK9-mediated degradation of the LDLR. This leads to an increased number of LDLRs on the surface of hepatocytes, which in turn enhances the clearance of LDL cholesterol (LDL-c) from the bloodstream.

Q2: What are the most common sources of batch-to-batch variability when working with **PCSK9 modulator-3**?

A2: Batch-to-batch variability for a small molecule inhibitor like **PCSK9 modulator-3** can stem from several factors. These include inconsistencies in the purity, potency, and solubility of different manufacturing lots. Variations in storage and handling can also lead to degradation of the compound. For consistent results, it is crucial to qualify each new batch and adhere strictly to storage and handling protocols.

Q3: How can I ensure the quality and consistency of a new batch of **PCSK9 modulator-3**?

A3: To ensure the quality and consistency of a new batch, a series of analytical and functional tests should be performed. This process, known as a comparability study, assesses the critical quality attributes (CQAs) of the new batch against a previously qualified reference standard. Key tests include identity confirmation, purity assessment (e.g., via HPLC), and potency determination through a functional assay, such as a PCSK9-LDLR binding assay or a cell-based LDL uptake assay.

Q4: My **PCSK9 modulator-3** shows high potency in a biochemical assay but is less effective in a cell-based assay. What could be the issue?

A4: Discrepancies between biochemical and cell-based assay results are common and can be attributed to several factors. These include poor cell permeability of the compound, potential for active efflux from the cells, or metabolic instability. It is also possible that the compound has low solubility in the cell culture medium, leading to precipitation and a lower effective concentration.

Q5: What are the recommended storage and handling conditions for **PCSK9 modulator-3**?

A5: Proper storage and handling are critical for maintaining the stability and activity of **PCSK9 modulator-3**. As a solid, it should be stored at 4°C and protected from light. Stock solutions, typically prepared in a solvent like DMSO, should be aliquoted and stored at -80°C to minimize freeze-thaw cycles. It is advisable to prepare fresh working solutions from the stock for each experiment.

Troubleshooting Guides

Issue 1: Inconsistent IC50/EC50 Values Between Batches

Potential Causes and Solutions

Potential Cause	Troubleshooting Steps
Variability in Compound Purity	<ol style="list-style-type: none">1. Request a Certificate of Analysis (CoA) for each new batch.2. Perform an independent purity analysis using High-Performance Liquid Chromatography (HPLC). Compare the chromatograms between batches to identify any new impurity peaks.
Differences in Compound Potency	<ol style="list-style-type: none">1. Establish a qualified reference standard from a batch with known, consistent performance.2. Perform a dose-response analysis for each new batch and the reference standard in parallel using a validated functional assay (e.g., PCSK9-LDLR binding assay).3. The IC50/EC50 values for the new batch should fall within a predefined acceptance range of the reference standard.
Compound Degradation	<ol style="list-style-type: none">1. Ensure the compound has been stored under the recommended conditions (4°C for solid, -80°C for stock solutions in solvent).2. Prepare fresh working solutions for each experiment.3. If degradation is suspected, re-test the batch using analytical methods like HPLC or mass spectrometry to assess its integrity.
Inaccurate Compound Concentration	<ol style="list-style-type: none">1. Verify the accuracy of the balance used for weighing the solid compound.2. Ensure complete dissolution of the compound when preparing stock solutions.3. Use calibrated pipettes for all dilutions.

Issue 2: Poor Reproducibility in Cell-Based Assays

Potential Causes and Solutions

Potential Cause	Troubleshooting Steps
Compound Precipitation in Media	<ol style="list-style-type: none">1. Visually inspect the cell culture media for any signs of precipitation after adding the compound.2. Determine the optimal final concentration of the solvent (e.g., DMSO) in the media, ensuring it is non-toxic to the cells (typically <1%).3. If solubility is an issue, consider preparing a higher concentration stock solution and using a smaller volume for dilution.
Variability in Cell Health and Density	<ol style="list-style-type: none">1. Maintain a consistent cell culture protocol, using cells within a defined passage number range.2. Ensure uniform cell seeding density across all wells of the microplate.3. Monitor cell viability to ensure the observed effects are not due to cytotoxicity.
Inconsistent Incubation Times and Temperatures	<ol style="list-style-type: none">1. Standardize all incubation steps in the protocol.2. Use a calibrated incubator with uniform temperature distribution to avoid plate edge effects.
High Background Signal	<ol style="list-style-type: none">1. Include appropriate controls, such as a vehicle-only control and cells-only control, to determine the baseline signal.2. If using a fluorescence-based assay, check for auto-fluorescence of the compound at the wavelengths used.

Experimental Protocols

Protocol 1: HPLC Analysis for Purity Assessment

This method provides a means to assess the purity of different batches of **PCSK9 modulator-3**.

- Preparation of Standard Solution: Accurately weigh and dissolve a reference standard of **PCSK9 modulator-3** in an appropriate solvent (e.g., DMSO) to a final concentration of 1 mg/mL.
- Preparation of Sample Solution: Prepare the new batch of **PCSK9 modulator-3** in the same manner as the standard solution.
- Chromatographic Conditions:
 - Column: C18 reverse-phase column (e.g., 4.6 mm x 150 mm, 5 μ m).
 - Mobile Phase: A gradient of acetonitrile and water with 0.1% trifluoroacetic acid.
 - Flow Rate: 1.0 mL/min.
 - Detection: UV at 280 nm.
- Analysis: Inject equal volumes of the standard and sample solutions. Compare the chromatograms for the retention time of the main peak and the presence of any impurity peaks. The purity of the new batch can be calculated based on the area of the main peak relative to the total peak area.

Protocol 2: Cell-Based LDL Uptake Assay

This assay measures the functional activity of **PCSK9 modulator-3** by quantifying the uptake of fluorescently labeled LDL in a relevant cell line (e.g., HepG2).

- Cell Seeding: Seed HepG2 cells in a 96-well plate at a density of 20,000 cells/well and allow them to adhere overnight.
- Serum Starvation (Optional): To upregulate LDLR expression, you may starve the cells in a serum-free medium for 12-24 hours.
- Compound Preparation: Prepare serial dilutions of **PCSK9 modulator-3** (from the new batch and the reference standard) in the cell culture medium.
- Treatment: Add the diluted compounds to the cells, along with a fixed concentration of recombinant human PCSK9. Include a vehicle control (e.g., DMSO). Incubate for a

predetermined time (e.g., 4 hours).

- LDL Uptake: Add fluorescently labeled LDL (e.g., DyLight™ 488-labeled LDL) to each well and incubate for 2-4 hours.
- Data Acquisition: Wash the cells to remove excess labeled LDL and measure the fluorescence intensity using a microplate reader.
- Data Analysis: Plot the fluorescence intensity against the compound concentration to generate dose-response curves and calculate the EC50 values for each batch.

Visualizations

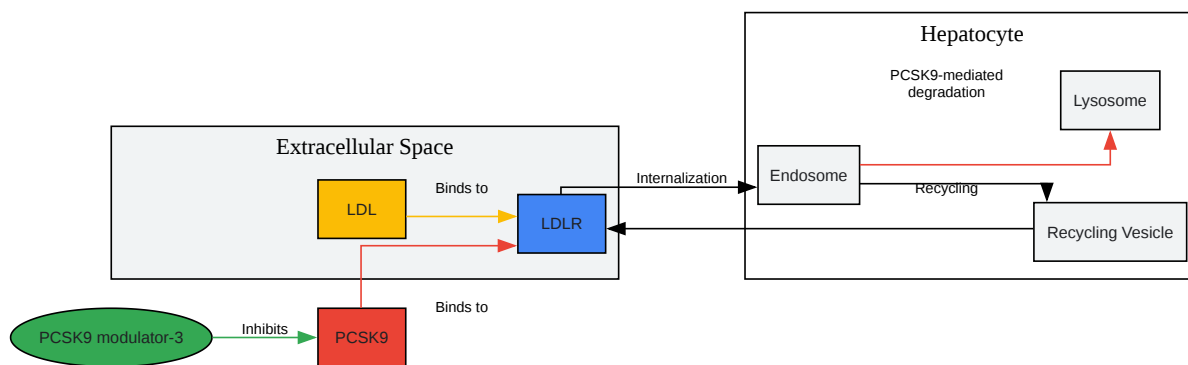

[Click to download full resolution via product page](#)

Caption: **PCSK9 modulator-3** inhibits the binding of PCSK9 to LDLR, preventing LDLR degradation.

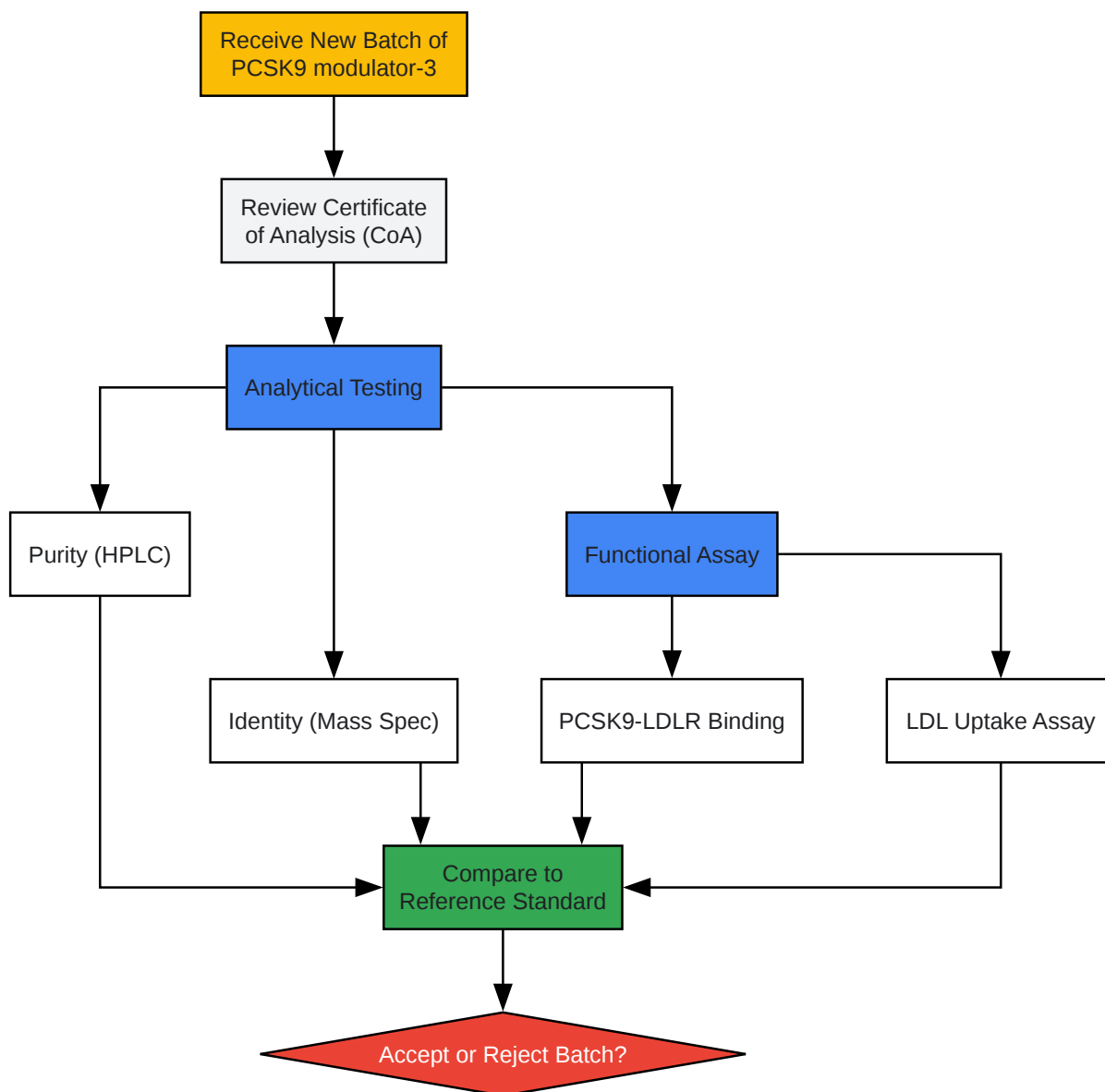

[Click to download full resolution via product page](#)

Caption: Experimental workflow for assessing batch-to-batch variability of **PCSK9 modulator-3**.

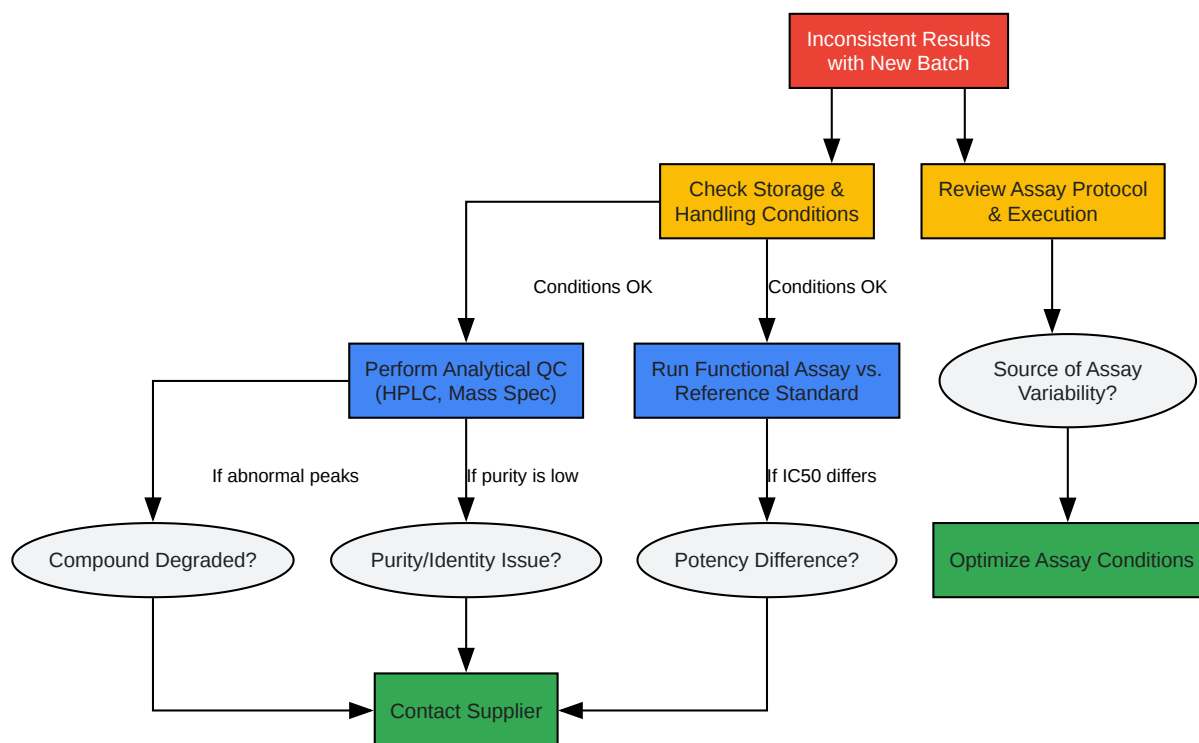

[Click to download full resolution via product page](#)

Caption: A decision tree for troubleshooting inconsistent results with **PCSK9 modulator-3**.

Need Custom Synthesis?

BenchChem offers custom synthesis for rare earth carbides and specific isotopic labeling.

Email: info@benchchem.com or [Request Quote Online](#).

References

- 1. [medchemexpress.com](https://www.medchemexpress.com) [medchemexpress.com]
- 2. [medchemexpress.com](https://www.medchemexpress.com) [medchemexpress.com]
- 3. [benchchem.com](https://www.benchchem.com) [benchchem.com]

- [4. nps.org.au \[nps.org.au\]](https://nps.org.au)
- [5. PCSK9 inhibitors – mechanisms of action - PMC \[pmc.ncbi.nlm.nih.gov\]](https://pubmed.ncbi.nlm.nih.gov/)
- To cite this document: BenchChem. ["PCSK9 modulator-3" batch-to-batch variability testing]. BenchChem, [2026]. [Online PDF]. Available at: [\[https://www.benchchem.com/product/b12406187/docs#pcsk9-modulator-3-batch-to-batch-variability-testing\]](https://www.benchchem.com/product/b12406187/docs#pcsk9-modulator-3-batch-to-batch-variability-testing)

Disclaimer & Data Validity:

The information provided in this document is for Research Use Only (RUO) and is strictly not intended for diagnostic or therapeutic procedures. While BenchChem strives to provide accurate protocols, we make no warranties, express or implied, regarding the fitness of this product for every specific experimental setup.

Technical Support: The protocols provided are for reference purposes. Unsure if this reagent suits your experiment?

Need Industrial/Bulk Grade? [Request Custom Synthesis Quote](#)

BenchChem

Our mission is to be the trusted global source of essential and advanced chemicals, empowering scientists and researchers to drive progress in science and industry.

Contact

Address: 3281 E Guasti Rd
Ontario, CA 91761, United States
Phone: (601) 213-4426
Email: info@benchchem.com

[Contact our Ph.D. Support Team for a compatibility check](#)