

# NMR spectroscopy techniques for euphane skeleton elucidation

**Author:** BenchChem Technical Support Team. **Date:** April 2026

## Compound of Interest

Compound Name: *(3A,24R)-3-(Acetyloxy)eupha-7,25-dien-24-ol*

Cat. No.: B12406035

[Get Quote](#)

## Application Notes & Protocols

Topic: Advanced NMR Spectroscopy Techniques for the Elucidation of the Euphane Skeleton

Audience: Researchers, scientists, and drug development professionals in natural product chemistry and medicinal chemistry.

## Abstract

The euphane skeleton, a tetracyclic triterpenoid core, is a common motif in a diverse range of bioactive natural products. Its complex, stereochemically rich structure presents a significant challenge for unambiguous characterization. Nuclear Magnetic Resonance (NMR) spectroscopy is the most powerful tool for the complete structural elucidation of these molecules, from establishing the planar carbon framework to defining the relative stereochemistry. This guide provides an in-depth overview of the strategic application of modern 1D and 2D NMR techniques for euphane skeleton elucidation. It moves beyond a simple listing of methods to explain the underlying logic of experimental selection and data integration, offering field-proven insights and a detailed protocol for acquiring a comprehensive NMR dataset.

## The Structural Challenge of the Euphane Skeleton

The euphane triterpenoid framework is a C<sub>30</sub> tetracyclic system characterized by a high degree of signal overlap in its <sup>1</sup>H NMR spectrum. This is due to the large number of non-aromatic, saturated CH, CH<sub>2</sub>, and CH<sub>3</sub> groups in similar chemical environments. Key challenges include:

- **Signal Congestion:** The aliphatic region ( $\delta$  0.7–2.5 ppm) is typically crowded with overlapping multiplets from methylene and methine protons, making direct interpretation of coupling constants difficult.[1]
- **Numerous Methyl Groups:** The euphane skeleton features up to eight methyl groups, many of which are singlets, providing limited connectivity information from scalar coupling alone.
- **Complex Stereochemistry:** The fused ring system contains multiple stereocenters, the relative configuration of which must be determined to define the molecule's three-dimensional structure.

Modern NMR spectroscopy, particularly 2D correlation techniques, provides the necessary tools to overcome these challenges systematically.[2]

## Foundational Analysis: 1D NMR Spectroscopy

The starting point for any structural elucidation is the acquisition of high-resolution 1D <sup>1</sup>H and <sup>13</sup>C NMR spectra.[3] These initial experiments provide a census of the protons and carbons in the molecule and offer crucial clues about the functional groups present.

### <sup>1</sup>H NMR Spectroscopy

The proton spectrum provides initial information on the number and type of protons. For euphane-type triterpenoids, characteristic signals include:

- **Methyl Singlets:** Typically 5-8 sharp singlets are observed between  $\delta$  0.7 and 1.2 ppm.
- **Oxygenated Methine:** The proton at C-3, often bearing a hydroxyl group, typically appears as a double-doublet around  $\delta$  3.2 ppm, with coupling constants indicating its axial or equatorial orientation.[4]

- Olefinic Protons: If a double bond is present in the skeleton (e.g., at C-8), the corresponding proton signal will appear downfield ( $\delta \sim 5.0-5.5$  ppm).

## <sup>13</sup>C NMR and DEPT Spectroscopy

The <sup>13</sup>C NMR spectrum reveals the total number of carbon atoms. Combined with Distortionless Enhancement by Polarization Transfer (DEPT) experiments (DEPT-45, -90, and -135), it allows for the classification of each carbon signal as a methyl (CH<sub>3</sub>), methylene (CH<sub>2</sub>), methine (CH), or quaternary carbon (C).<sup>[5]</sup> This information is fundamental for piecing together the molecular structure.

Table 1: Characteristic <sup>1</sup>H and <sup>13</sup>C NMR Chemical Shifts for the Euphol Skeleton (CDCl<sub>3</sub>)

Position	<sup>13</sup> C Chemical Shift (δ ppm)[6]	<sup>1</sup> H Chemical Shift (δ ppm)[6]	Multiplicity, J (Hz)
1	35.7	1.58, 0.95	m
2	27.8	1.66	m
3	78.9	3.23	dd, 11.5, 4.5
4	38.9	-	-
5	51.0	0.82	m
6	19.2	1.55	m
7	28.1	2.05	m
8	134.0	-	-
9	134.4	5.30	m
10	37.3	-	-
18	15.9	0.87	s
19	20.0	0.96	s
20	36.1	2.02	m
21	18.7	0.96	d, 6.3
28	29.8	1.02	s
29	22.0	0.76	s
30	24.5	0.85	s

Note: This table provides representative values for the parent compound euphol. Substituent effects will alter these shifts.

## Assembling the Planar Structure: 2D Correlation NMR

2D NMR experiments are essential for establishing the connectivity of the carbon skeleton by correlating nuclei through chemical bonds.[7][8]

## **$^1\text{H}$ - $^1\text{H}$ COSY (Correlation Spectroscopy)**

The COSY experiment identifies protons that are coupled to each other, typically through two or three bonds ( $^2\text{JHH}$ ,  $^3\text{JHH}$ ).[9] This is the primary tool for tracing out proton spin systems. For a euphane skeleton, COSY helps to:

- Connect protons within the same ring system (e.g., tracing from H-1 to H-2 to H-3).
- Establish connectivity in the side chain.
- Confirm the presence of CH-CH<sub>2</sub>-CH fragments.

## **$^1\text{H}$ - $^{13}\text{C}$ HSQC (Heteronuclear Single Quantum Coherence)**

The HSQC experiment correlates each proton with the carbon atom it is directly attached to ( $^1\text{JCH}$ ).[10] This is a highly sensitive and indispensable experiment that definitively links the proton and carbon frameworks. By overlaying the HSQC with the  $^1\text{H}$  and  $^{13}\text{C}$  spectra, one can assign the carbon signal for every protonated carbon.

## **$^1\text{H}$ - $^{13}\text{C}$ HMBC (Heteronuclear Multiple Bond Correlation)**

The HMBC experiment is arguably the most critical for elucidating the complete carbon skeleton. It reveals correlations between protons and carbons that are two or three bonds away ( $^2\text{JCH}$ ,  $^3\text{JCH}$ ).[5] This long-range information is used to connect the spin systems established by COSY and to place quaternary carbons, which are invisible in HSQC. Key HMBC correlations for the euphane skeleton include:

- Correlations from the angular methyl protons (e.g., Me-18, Me-19, Me-28, Me-29, Me-30) to adjacent quaternary and methine carbons, which effectively stitch the ring system together.
- Correlations from olefinic or methine protons to nearby carbons, confirming ring junctions and the placement of functional groups.

## Defining the 3D Structure: NOESY and ROESY

Once the planar structure is established, the next step is to determine the relative stereochemistry. This is achieved using through-space correlations detected by the Nuclear Overhauser Effect (NOE).<sup>[11]</sup>

### NOESY (Nuclear Overhauser Effect Spectroscopy)

The NOESY experiment detects protons that are close to each other in space (typically  $< 5 \text{ \AA}$ ), regardless of whether they are connected through bonds.<sup>[12]</sup> For rigid, fused ring systems like euphane, NOESY is powerful for determining the relative orientation of substituents and ring junctions. Key NOE correlations often observed are:

- 1,3-diaxial interactions between axial protons and methyl groups.
- Correlations between protons on the  $\alpha$ -face and  $\beta$ -face of the steroid-like core, which helps to assign the stereochemistry at ring junctions. For instance, a correlation between H-5 and Me-28, and between Me-18 and H-20, is characteristic of the euphane stereochemistry.<sup>[13]</sup>

### ROESY (Rotating-frame Overhauser Effect Spectroscopy)

For medium-sized molecules (MW  $\sim 700$ -1200 Da), the standard NOE can be close to zero, making NOESY experiments ineffective.<sup>[14]</sup> In such cases, the ROESY experiment is the preferred alternative. It detects the same through-space interactions but is effective across a wider range of molecular weights.<sup>[12]</sup><sup>[14]</sup>

## Integrated Workflow for Elucidation

The elucidation process is a logical, iterative puzzle. The data from each experiment provides clues that, when combined, lead to the final structure.

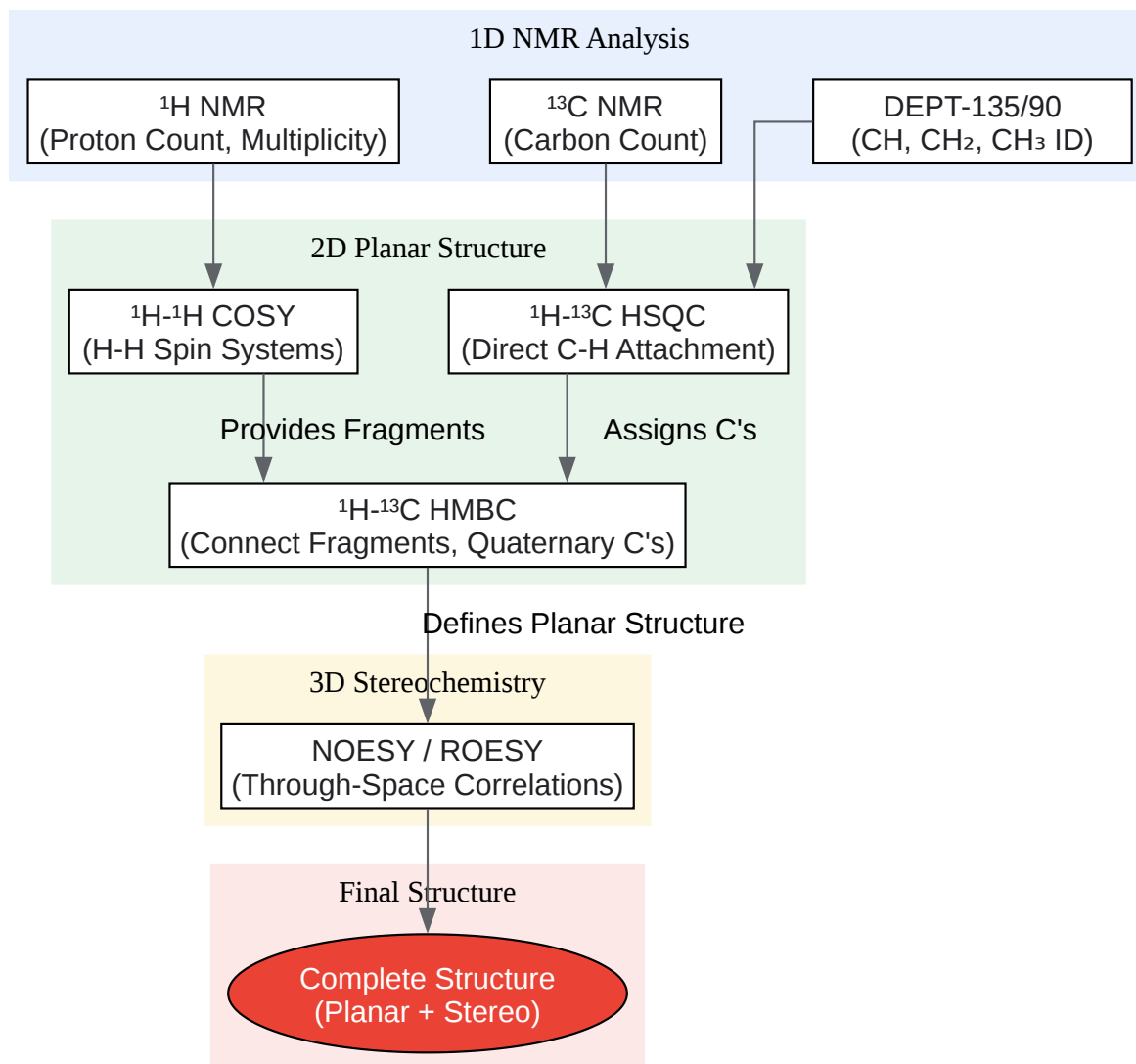

[Click to download full resolution via product page](#)

### Need Custom Synthesis?

BenchChem offers custom synthesis for rare earth carbides and specific isotopic labeling.

Email: [info@benchchem.com](mailto:info@benchchem.com) or [Request Quote Online](#).

## Sources

- 1. NMR based quantitation of cycloartane triterpenes in black cohosh extracts - PMC [[pmc.ncbi.nlm.nih.gov](https://pubmed.ncbi.nlm.nih.gov/)]
- 2. [acdlabs.com](https://www.acdlabs.com/) [[acdlabs.com](https://www.acdlabs.com/)]
- 3. [researchgate.net](https://www.researchgate.net/) [[researchgate.net](https://www.researchgate.net/)]
- 4. Trisnor-Euphane-Type Triterpenoid and Other Constituents Isolated from Euphorbia tanquahuete Sessé & Moc.: Preparation and Cytotoxic Evaluation of Semisynthetic Derivatives of Euphol - PMC [[pmc.ncbi.nlm.nih.gov](https://pubmed.ncbi.nlm.nih.gov/)]
- 5. [emerypharma.com](https://www.emerypharma.com/) [[emerypharma.com](https://www.emerypharma.com/)]
- 6. [researchgate.net](https://www.researchgate.net/) [[researchgate.net](https://www.researchgate.net/)]
- 7. [ccc.chem.pitt.edu](https://ccc.chem.pitt.edu/) [[ccc.chem.pitt.edu](https://ccc.chem.pitt.edu/)]
- 8. [epfl.ch](https://www.epfl.ch/) [[epfl.ch](https://www.epfl.ch/)]
- 9. 7) Common 2D (COSY, HSQC, HMBC) | SDSU NMR Facility – Department of Chemistry [[nmr.sdsu.edu](https://nmr.sdsu.edu/)]
- 10. [youtube.com](https://www.youtube.com/) [[youtube.com](https://www.youtube.com/)]
- 11. [chem.libretexts.org](https://chem.libretexts.org/) [[chem.libretexts.org](https://chem.libretexts.org/)]
- 12. [nmr.chem.columbia.edu](https://nmr.chem.columbia.edu/) [[nmr.chem.columbia.edu](https://nmr.chem.columbia.edu/)]
- 13. [cpb.pharm.or.jp](https://cpb.pharm.or.jp/) [[cpb.pharm.or.jp](https://cpb.pharm.or.jp/)]
- 14. UCSD SSPPS NMR Facility: NOESY and ROESY [[sopnmr.blogspot.com](https://sopnmr.blogspot.com/)]
- To cite this document: BenchChem. [NMR spectroscopy techniques for euphane skeleton elucidation]. BenchChem, [2026]. [Online PDF]. Available at: [<https://www.benchchem.com/product/b12406035/docs#nmr-spectroscopy-techniques-for-euphane-skeleton-elucidation>]

---

### Disclaimer & Data Validity:

The information provided in this document is for Research Use Only (RUO) and is strictly not intended for diagnostic or therapeutic procedures. While BenchChem strives to provide accurate protocols, we make no warranties, express or implied, regarding the fitness of this product for every specific experimental setup.

**Technical Support:** The protocols provided are for reference purposes. Unsure if this reagent suits your experiment?

**Need Industrial/Bulk Grade?** [Request Custom Synthesis Quote](#)

## BenchChem

Our mission is to be the trusted global source of essential and advanced chemicals, empowering scientists and researchers to drive progress in science and industry.

### Contact

Address: 3281 E Guasti Rd  
Ontario, CA 91761, United States  
Phone: (601) 213-4426  
Email: [info@benchchem.com](mailto:info@benchchem.com)

[Contact our Ph.D. Support Team for a compatibility check](#)