

# Independent Verification of G-{d-Arg}-GDSPASSK Research Findings: A Comparative Guide

**Author:** BenchChem Technical Support Team. **Date:** April 2026

## Compound of Interest

Compound Name: G-{d-Arg}-GDSPASSK

Cat. No.: B12406564

[Get Quote](#)

For Researchers, Scientists, and Drug Development Professionals

This guide provides an objective comparison of the polypeptide **G-{d-Arg}-GDSPASSK** with alternative therapeutic agents for wound healing and tissue repair. Due to the limited publicly available research on **G-{d-Arg}-GDSPASSK**, this document summarizes its stated function and draws comparisons with more extensively studied alternatives, providing supporting experimental data where available.

## Overview of G-{d-Arg}-GDSPASSK

**G-{d-Arg}-GDSPASSK** is a synthetic polypeptide designed to inhibit cell adhesion, a mechanism intended to facilitate wound healing and promote tissue repair. Its sequence contains the well-known Arginine-Glycine-Aspartate (RGD) motif, which is a common recognition site for integrins, a family of cell surface receptors that mediate cell-matrix and cell-cell adhesion. The presence of a D-amino acid (d-Arg) suggests a potential for increased stability against enzymatic degradation compared to peptides composed solely of L-amino acids.

Despite its commercial availability, detailed peer-reviewed studies quantifying the efficacy, elucidating the specific signaling pathways, and providing comprehensive experimental protocols for **G-{d-Arg}-GDSPASSK** are not readily accessible in the public domain. Therefore, this guide will focus on comparing its proposed mechanism of action with established alternatives.

## Comparative Analysis of Wound Healing Agents

The following table summarizes the performance of **G-{d-Arg}-GDSPASSK** based on available information and compares it with well-researched alternatives.

Compound/Therapy	Proposed Mechanism of Action	Reported Efficacy	Key Experimental Findings
G-{d-Arg}-GDSPASSK	Inhibition of cell adhesion via integrin binding.	Stated to promote wound healing and tissue repair.	Specific quantitative data from peer-reviewed studies is not publicly available.
RGD-containing Peptides	Competitive inhibition of integrin-ligand interactions, modulating cell adhesion, migration, and proliferation.	Dose-dependent acceleration of epithelial migration and wound closure. In a study on diabetic foot ulcers, an RGD peptide matrix resulted in complete healing in 35% of patients versus 8% in the placebo group[1].	A synthetic RGD-peptide matrix significantly accelerated the resurfacing of second-degree burn wounds in pigs, with 57% of treated wounds completely epithelized by day 7, compared to 13% for the control group[2].
GHK-Cu (Copper Peptide)	Stimulates collagen and glycosaminoglycan synthesis, modulates metalloproteinases, and attracts immune and endothelial cells. It also exhibits anti-inflammatory effects.	Accelerates wound healing, increases blood vessel formation, and improves healing of diabetic and ischemic wounds in animal models.	In diabetic rats, GHK-Cu incorporated into a collagen matrix accelerated wound contraction and increased collagen synthesis nine-fold compared to controls in healthy rats[3].
Cathelicidins (e.g., LL-37)	Promotes proliferation and migration of keratinocytes, fibroblasts, and endothelial cells. It also has antimicrobial properties.	Accelerates wound healing in both infected and non-infected wounds in rodent models.	Cathelicidin-DM was shown to promote the proliferation of human keratinocytes (HaCaT), skin fibroblasts (HSF), and human umbilical vein endothelial cells

(HUVEC) in a concentration-dependent manner[4]. It also accelerated skin wound healing and promoted re-epithelialization and granulation tissue formation in mice[4].

---

## Experimental Protocols

Detailed experimental protocols for **G-{d-Arg}-GDSPASSK** are not available in published literature. However, standard assays used to evaluate the efficacy of wound healing agents that inhibit cell adhesion are described below.

### Cell Adhesion Assay

- **Plate Coating:** Coat 96-well plates with an extracellular matrix (ECM) protein (e.g., fibronectin, vitronectin) at a concentration of 10 µg/mL in a suitable buffer (e.g., PBS) and incubate overnight at 4°C.
- **Blocking:** Wash the plates with PBS and block non-specific binding sites with 1% Bovine Serum Albumin (BSA) in PBS for 1 hour at 37°C.
- **Cell Preparation:** Harvest cells (e.g., human fibroblasts) and resuspend them in a serum-free medium.
- **Treatment:** Incubate the cells with varying concentrations of the test peptide (e.g., **G-{d-Arg}-GDSPASSK**) for 30 minutes.
- **Seeding:** Add the cell-peptide suspension to the coated wells and incubate for 1-2 hours at 37°C to allow for cell adhesion.
- **Washing:** Gently wash the wells with PBS to remove non-adherent cells.

- **Quantification:** Quantify the number of adherent cells using a suitable method, such as crystal violet staining or a fluorescence-based assay. The results are typically expressed as the percentage of cell adhesion relative to an untreated control.

## Fibroblast Migration (Scratch) Assay

- **Cell Seeding:** Seed fibroblasts into 6-well plates and grow them to confluence.
- **Scratching:** Create a uniform "scratch" in the cell monolayer using a sterile pipette tip.
- **Treatment:** Wash the wells to remove detached cells and add a medium containing the test peptide at various concentrations.
- **Imaging:** Capture images of the scratch at time 0 and at subsequent time points (e.g., 12, 24, and 48 hours).
- **Analysis:** Measure the width of the scratch at different points and calculate the percentage of wound closure over time. A higher percentage of closure indicates enhanced cell migration.

## In Vivo Wound Healing Model (Murine)

- **Animal Model:** Use a suitable mouse model (e.g., C57BL/6).
- **Wound Creation:** Create full-thickness excisional or incisional wounds on the dorsal side of the anesthetized mice.
- **Treatment:** Topically apply a formulation containing the test peptide to the wound site. A control group should receive the vehicle alone.
- **Monitoring:** Photograph the wounds at regular intervals (e.g., days 3, 7, 10, 14) to monitor wound closure.
- **Analysis:** Calculate the wound area at each time point and express it as a percentage of the initial wound area.
- **Histology:** At the end of the study, excise the wound tissue for histological analysis (e.g., H&E and Masson's trichrome staining) to assess re-epithelialization, collagen deposition, and granulation tissue formation.

## Signaling Pathways and Logical Relationships

The precise signaling pathway activated by **G-{d-Arg}-GDSPASSK** has not been experimentally determined. However, based on its RGD motif, it is hypothesized to interact with integrin receptors. The binding of RGD-containing peptides to integrins can trigger downstream signaling cascades that are crucial for wound healing.

### Hypothesized Signaling Pathway for G-{d-Arg}-GDSPASSK

The following diagram illustrates a plausible signaling pathway initiated by the binding of an RGD-containing peptide to integrin receptors, leading to cellular responses that promote wound healing. This is a generalized pathway and may not represent the exact mechanism of **G-{d-Arg}-GDSPASSK**.

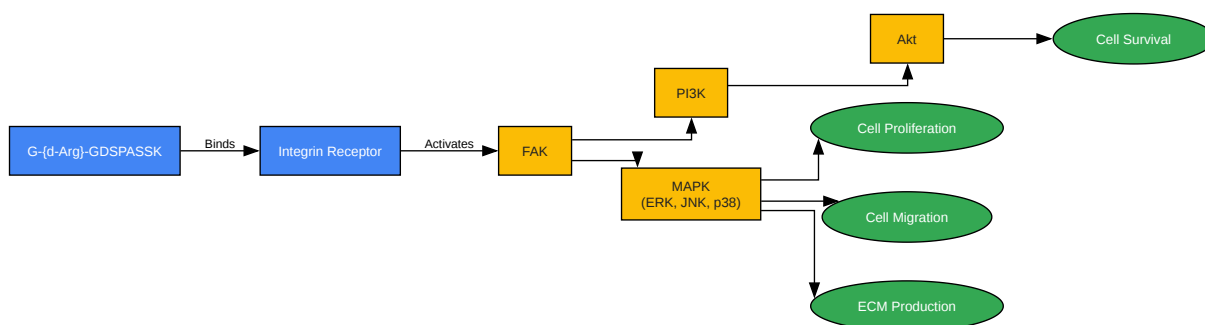

[Click to download full resolution via product page](#)

Caption: Hypothesized integrin-mediated signaling pathway for RGD-containing peptides.

## Experimental Workflow for Evaluating Wound Healing Peptides

The logical flow for the preclinical evaluation of a novel wound healing peptide is outlined in the diagram below.

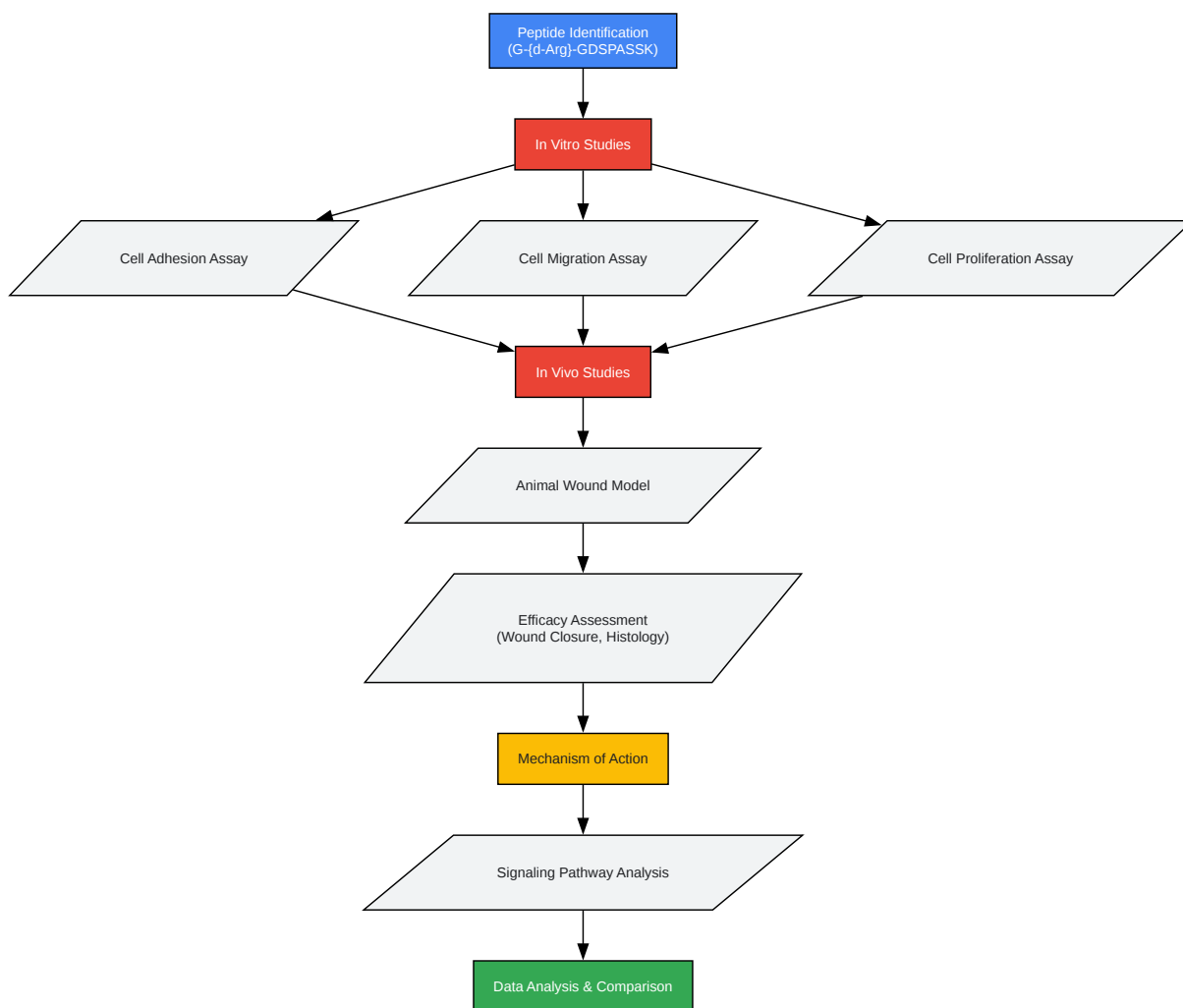

[Click to download full resolution via product page](#)

Caption: Standard preclinical workflow for wound healing peptide evaluation.

## Conclusion

**G-{d-Arg}-GDSPASSK** holds theoretical promise as a wound healing agent due to its RGD motif and potential for increased stability. However, a significant gap exists in the publicly available scientific literature regarding its specific performance and mechanism of action. In contrast, other RGD-containing peptides, GHK-Cu, and cathelicidins have a more substantial body of research supporting their efficacy in promoting wound healing through various, well-defined mechanisms.

For researchers and drug development professionals, **G-{d-Arg}-GDSPASSK** may warrant further investigation to independently verify its therapeutic potential and to elucidate its pharmacological properties. The experimental protocols and comparative data provided in this guide for alternative compounds can serve as a benchmark for such an evaluation. Without direct comparative studies, it is not possible to definitively conclude the superiority of **G-{d-Arg}-GDSPASSK** over these established alternatives.

### *Need Custom Synthesis?*

*BenchChem offers custom synthesis for rare earth carbides and specific isotopic labeling.*

*Email: [info@benchchem.com](mailto:info@benchchem.com) or [Request Quote Online](#).*

## References

- [1. Promotion and acceleration of diabetic ulcer healing by arginine-glycine-aspartic acid \(RGD\) peptide matrix. RGD Study Group - PubMed \[pubmed.ncbi.nlm.nih.gov\]](#)
- [2. Effects of an arginine-glycine-aspartic acid peptide-containing artificial matrix on epithelial migration in vitro and experimental second-degree burn wound healing in vivo - PubMed \[pubmed.ncbi.nlm.nih.gov\]](#)
- [3. researchgate.net \[researchgate.net\]](#)
- [4. Comparison of Linear vs. Cyclic RGD Pentapeptide Interactions with Integrin  \$\alpha\beta3\$  by Molecular Dynamics Simulations - PMC \[pmc.ncbi.nlm.nih.gov\]](#)

- To cite this document: BenchChem. [Independent Verification of G-{d-Arg}-GDSPASSK Research Findings: A Comparative Guide]. BenchChem, [2026]. [Online PDF]. Available at: [<https://www.benchchem.com/product/b12406564/docs#independent-verification-of-g-d-arg-gdspassk-research-findings-a-comparative-guide>]

---

### Disclaimer & Data Validity:

The information provided in this document is for Research Use Only (RUO) and is strictly not intended for diagnostic or therapeutic procedures. While BenchChem strives to provide accurate protocols, we make no warranties, express or implied, regarding the fitness of this product for every specific experimental setup.

**Technical Support:** The protocols provided are for reference purposes. Unsure if this reagent suits your experiment?

**Need Industrial/Bulk Grade?** [Request Custom Synthesis Quote](#)

## BenchChem

Our mission is to be the trusted global source of essential and advanced chemicals, empowering scientists and researchers to drive progress in science and industry.

### Contact

Address: 3281 E Guasti Rd

Ontario, CA 91761, United States

Phone: (601) 213-4426

Email: [info@benchchem.com](mailto:info@benchchem.com)

[Contact our Ph.D. Support Team for a compatibility check](#)