

FG 488 BAPTA-2 AM: A Technical Guide for Neuroscience Research

Author: BenchChem Technical Support Team. **Date:** April 2026

Compound of Interest

Compound Name: FG 488 BAPTA-2 AM

Cat. No.: B12406892

[Get Quote](#)

For Researchers, Scientists, and Drug Development Professionals

FG 488 BAPTA-2 AM is a high-performance, visible light-excitable fluorescent indicator for the quantitative measurement of intracellular calcium concentration ($[Ca^{2+}]_i$). Its utility in neuroscience stems from its ability to transform transient changes in neuronal and glial calcium levels into a detectable fluorescent signal, providing a window into cellular activity, signaling pathways, and neurophysiology. This guide offers an in-depth overview of its properties, experimental applications, and data interpretation for neuroscience research.

Core Principles and Mechanism of Action

FG 488 BAPTA-2 AM is the cell-permeant acetoxymethyl (AM) ester form of the calcium chelator BAPTA (1,2-bis(o-aminophenoxy)ethane-N,N,N',N'-tetraacetic acid) conjugated to a fluorescein-based fluorophore, Oregon Green™ 488. The AM ester modification renders the molecule lipophilic, allowing it to passively diffuse across the cell membrane into the cytoplasm. Once inside the cell, ubiquitous intracellular esterases cleave the AM ester groups, trapping the now cell-impermeant FG 488 BAPTA-2 in the cytosol.

The fluorescence of FG 488 BAPTA-2 is highly dependent on the concentration of free Ca^{2+} . In its calcium-free state, the dye exhibits a low level of fluorescence. Upon binding to Ca^{2+} , a

conformational change in the BAPTA chelating moiety leads to a significant increase in the quantum yield of the Oregon Green™ 488 fluorophore, resulting in a dramatic enhancement of its fluorescence intensity. This direct correlation between intracellular calcium concentration and fluorescence makes it an invaluable tool for dynamic calcium imaging in live cells.

Quantitative Data Summary

The photophysical and chemical properties of FG 488 BAPTA-2 are critical for experimental design and data interpretation. The following tables summarize its key quantitative parameters.

Property	Value	Reference
Excitation Wavelength (Max)	~494 nm	[1]
Emission Wavelength (Max)	~523 nm	[1]
Dissociation Constant (Kd) for Ca ²⁺	~580 nM	[2][3]
Fluorescence Intensity Increase upon Ca ²⁺ Binding	~100-fold	[4]
Extinction Coefficient (ε) at 496 nm	118,000 M ⁻¹ cm ⁻¹	[5]

Comparison with Similar Calcium Indicators

Indicator	Dissociation Constant (Kd)	Fluorescence Enhancement	Excitation/Emission Maxima
FG 488 BAPTA-2 AM	~580 nM	~100-fold	~494/523 nm
Oregon Green 488 BAPTA-1 AM	~170 nM	~14-fold	~494/523 nm[2][6]
Fluo-4 AM	~345 nM	~100-fold	~494/516 nm[4]
Fura-2 AM	~145 nM	Ratiometric (Shift in Excitation)	340/380 nm (Excitation), ~510 nm (Emission)

Experimental Protocols

Loading FG 488 BAPTA-2 AM into Cultured Neurons

This protocol provides a general guideline for loading cultured neurons. Optimal concentrations and incubation times should be empirically determined for specific cell types and experimental conditions.

Materials:

- **FG 488 BAPTA-2 AM**
- Anhydrous Dimethyl Sulfoxide (DMSO)
- Pluronic F-127 (20% solution in DMSO)
- Physiological saline solution appropriate for the neurons (e.g., Hanks' Balanced Salt Solution (HBSS) or artificial cerebrospinal fluid (aCSF))
- Cultured neurons on coverslips

Procedure:

- **Prepare Stock Solution:** Dissolve **FG 488 BAPTA-2 AM** in anhydrous DMSO to a stock concentration of 1-5 mM. Aliquot and store at -20°C, protected from light and moisture.
- **Prepare Loading Solution:** On the day of the experiment, dilute the **FG 488 BAPTA-2 AM** stock solution in the appropriate physiological saline to a final concentration of 1-5 μM. To aid in solubilization and prevent dye sequestration, add Pluronic F-127 to a final concentration of 0.02-0.04%. Vortex vigorously to ensure complete mixing.
- **Cell Loading:** Replace the culture medium with the prepared loading solution. Incubate the cells for 30-60 minutes at 37°C in a dark environment (e.g., a cell culture incubator).
- **Wash and De-esterification:** After incubation, gently wash the cells two to three times with fresh, pre-warmed physiological saline to remove extracellular dye.

- Incubation for De-esterification: Incubate the cells for an additional 30 minutes at room temperature in the dark to allow for complete de-esterification of the AM ester by intracellular esterases.
- Imaging: The cells are now ready for calcium imaging using a fluorescence microscope equipped with appropriate filters for Oregon Green™ 488 (e.g., a standard FITC filter set).

Bulk Loading of FG 488 BAPTA-2 AM in Brain Slices

This protocol is adapted from methods for loading similar AM ester dyes into acute brain slices.

Materials:

- **FG 488 BAPTA-2 AM**
- Anhydrous DMSO
- Pluronic F-127 (20% solution in DMSO)
- Cremophor EL (optional, to aid in solubilization)
- Artificial cerebrospinal fluid (aCSF), continuously bubbled with 95% O₂ / 5% CO₂
- Acute brain slices (200-400 µm thick)

Procedure:

- Prepare Dye Injectate: Prepare a concentrated stock solution of **FG 488 BAPTA-2 AM** in DMSO (e.g., 1 mM). Mix with an equal volume of 20% Pluronic F-127 in DMSO.
- Slice Recovery: Allow the freshly prepared brain slices to recover in oxygenated aCSF at room temperature for at least 1 hour.
- Dye Loading: Transfer the slices to a small incubation chamber containing oxygenated aCSF. Lower the objective of a microscope to the region of interest within the slice. Using a patch pipette filled with the dye injectate, apply gentle positive pressure to slowly eject the dye into the tissue. Alternatively, for bulk loading, incubate the slices in aCSF containing 5-10 µM **FG 488 BAPTA-2 AM** and 0.02-0.05% Pluronic F-127 for 30-60 minutes at 37°C.[7]

- **Wash and De-esterification:** After loading, transfer the slices back to a holding chamber with fresh, continuously oxygenated aCSF for at least 30 minutes to allow for de-esterification and to wash out excess dye.
- **Imaging:** Mount the slice in a recording chamber on the microscope stage, continuously perfused with oxygenated aCSF. Use a fluorescence or confocal microscope for imaging.

Signaling Pathways and Experimental Workflows

Mechanism of Intracellular Calcium Measurement

The following diagram illustrates the process of loading, activation, and calcium binding of **FG 488 BAPTA-2 AM** within a neuron.

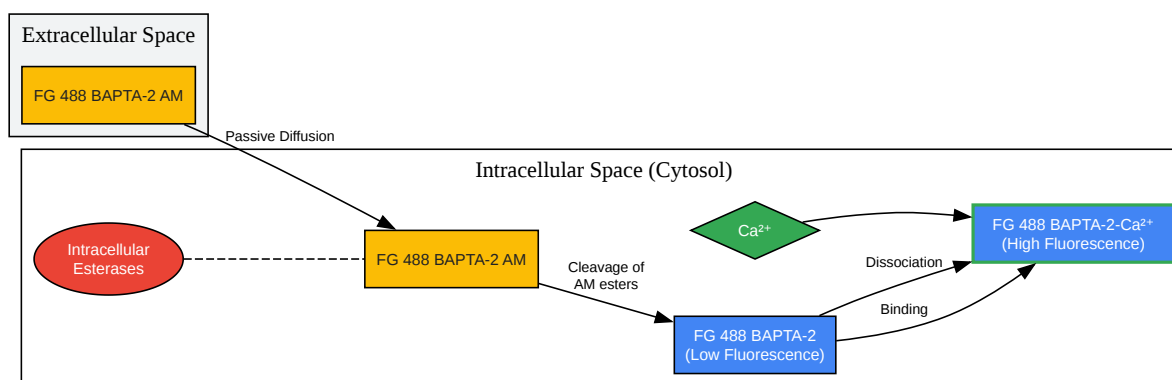

[Click to download full resolution via product page](#)

Caption: Intracellular conversion and action of **FG 488 BAPTA-2 AM**.

Typical Calcium Imaging Experimental Workflow

The following diagram outlines a standard workflow for a calcium imaging experiment in neuroscience research.

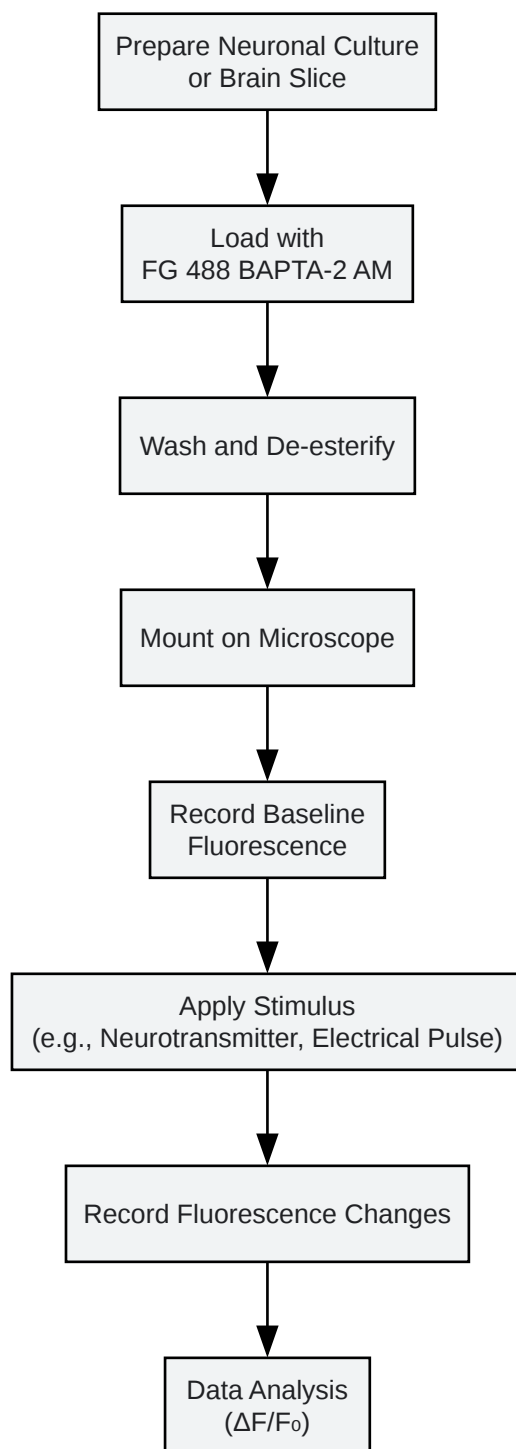

[Click to download full resolution via product page](#)

Caption: Standard experimental workflow for calcium imaging.

Applications in Neuroscience

FG 488 BAPTA-2 AM is a versatile tool for a wide range of neuroscience applications, including:

- **Monitoring Neuronal Activity:** Correlating calcium transients with action potentials to study firing patterns in single neurons and neuronal populations.
- **Investigating Synaptic Transmission:** Measuring calcium influx in presynaptic terminals and postsynaptic compartments to study synaptic plasticity.
- **Glial Cell Signaling:** Visualizing calcium waves in astrocytes and other glial cells to understand their role in neuro-glial communication.
- **High-Throughput Screening:** In drug discovery, for screening compounds that modulate neuronal activity by affecting ion channels or receptors that influence intracellular calcium.
- **Studying Neurodegenerative Diseases:** Investigating alterations in calcium homeostasis that are implicated in the pathophysiology of diseases such as Alzheimer's and Parkinson's.

By providing a robust and sensitive method for measuring intracellular calcium dynamics, **FG 488 BAPTA-2 AM** continues to be an essential tool for advancing our understanding of the nervous system in both health and disease.

Need Custom Synthesis?

BenchChem offers custom synthesis for rare earth carbides and specific isotopic labeling.

Email: info@benchchem.com or [Request Quote Online](#).

References

- [1. Fluorescent Ca²⁺ Indicators Excited with Visible Light—Section 19.3 | Thermo Fisher Scientific - HK \[thermofisher.com\]](#)
- [2. Chemical Calcium Indicators - PMC \[pmc.ncbi.nlm.nih.gov\]](#)
- [3. researchgate.net \[researchgate.net\]](#)
- [4. Functional Multiple-Spine Calcium Imaging from Brain Slices - PMC \[pmc.ncbi.nlm.nih.gov\]](#)

- [5. A comparison of fluorescent Ca²⁺ indicators for imaging local Ca²⁺ signals in cultured cells - PMC \[pmc.ncbi.nlm.nih.gov\]](#)
- [6. The Impact of Optical Undersampling on the Ca²⁺ Signal Resolution in Ca²⁺ Imaging of Spontaneous Neuronal Activity - PubMed \[pubmed.ncbi.nlm.nih.gov\]](#)
- [7. Calcium imaging and BAPTA loading of amygdala astrocytes in mouse brain slices - PMC \[pmc.ncbi.nlm.nih.gov\]](#)
- To cite this document: BenchChem. [FG 488 BAPTA-2 AM: A Technical Guide for Neuroscience Research]. BenchChem, [2026]. [Online PDF]. Available at: [\[https://www.benchchem.com/product/b12406892/docs#fg-488-bapta-2-am-a-technical-guide-for-neuroscience-research\]](https://www.benchchem.com/product/b12406892/docs#fg-488-bapta-2-am-a-technical-guide-for-neuroscience-research)

Disclaimer & Data Validity:

The information provided in this document is for Research Use Only (RUO) and is strictly not intended for diagnostic or therapeutic procedures. While BenchChem strives to provide accurate protocols, we make no warranties, express or implied, regarding the fitness of this product for every specific experimental setup.

Technical Support: The protocols provided are for reference purposes. Unsure if this reagent suits your experiment?

Need Industrial/Bulk Grade? [Request Custom Synthesis Quote](#)

BenchChem

Our mission is to be the trusted global source of essential and advanced chemicals, empowering scientists and researchers to drive progress in science and industry.

Contact

Address: 3281 E Guasti Rd
Ontario, CA 91761, United States
Phone: (601) 213-4426
Email: info@benchchem.com

Contact our Ph.D. Support Team for a compatibility check