

Application Notes and Protocols for the Determination of Water Hardness Using Thymolphthalexon

Author: BenchChem Technical Support Team. **Date:** April 2026

Compound of Interest

Compound Name: *Thymolphthalexon*

Cat. No.: *B12406562*

[Get Quote](#)

Introduction and Principle

Water hardness is a common quality parameter that is primarily attributed to the presence of dissolved divalent cations, most notably calcium (Ca^{2+}) and magnesium (Mg^{2+}).^[1] The accurate determination of these ions is critical in numerous scientific and industrial fields, including pharmaceutical manufacturing and drug development, where water quality can significantly influence process efficiency and product stability.

Complexometric titration stands as a standard analytical technique for quantifying metal ion concentrations.^[1] This method involves the use of a chelating agent, typically ethylenediaminetetraacetic acid (EDTA), which forms stable, colorless complexes with metal ions.^{[2][3]} To visually identify the endpoint of the titration, a metallochromic indicator is employed. This indicator changes color when it is displaced from the metal-indicator complex by the stronger chelating agent, EDTA.^[4]

Thymolphthalexon, also known as Thymolphthalein Complexone, serves as a highly effective metallochromic indicator for the complexometric titration of alkaline earth metals such as calcium.^[4] In a highly alkaline medium ($\text{pH} > 12$), **thymolphthalexon** forms a distinct blue

colored complex with calcium ions.[1] During the titration with EDTA, the EDTA, being a more potent chelating agent, sequesters the calcium ions from the indicator complex.[4] The endpoint is signaled by a sharp color change from blue to colorless or a faint pink, indicating that all the calcium ions have been complexed by the EDTA.[1] At this high pH, magnesium ions are precipitated as magnesium hydroxide ($\text{Mg}(\text{OH})_2$), thus preventing their interference in the determination of calcium hardness.[1][5]

Experimental Protocols

This section details the necessary reagents and the step-by-step procedure for the determination of calcium hardness using **thymolphthalexon**.

Reagent Preparation

- Standard 0.01 M EDTA Solution:
 - Dry approximately 3.7224 g of analytical grade disodium ethylenediaminetetraacetate dihydrate ($\text{Na}_2\text{EDTA}\cdot 2\text{H}_2\text{O}$) at 80°C for 2 hours.[1]
 - Cool in a desiccator.
 - Accurately weigh the dried solid and dissolve it in deionized water in a 1000 mL volumetric flask.
 - Make up the solution to the mark with deionized water and mix thoroughly.[1]
- **Thymolphthalexon** Indicator Solution (0.5% w/v):
 - Dissolve 0.5 g of **thymolphthalexon** powder in 100 mL of 95% ethanol.[1]
- Sodium Hydroxide Solution (2 M):
 - Carefully dissolve 80 g of sodium hydroxide (NaOH) pellets in approximately 800 mL of deionized water in a beaker, as the dissolution process is exothermic.[1]
 - Allow the solution to cool to room temperature.

- Quantitatively transfer the cooled solution to a 1000 mL volumetric flask and dilute to the mark with deionized water.[1]

Titration Protocol for Calcium Hardness

- Sample Preparation:
 - Using a pipette, transfer 50.0 mL of the water sample into a 250 mL Erlenmeyer flask.[1]
- pH Adjustment:
 - Add 2 mL of the 2 M NaOH solution to the water sample in the flask. This will raise the pH to approximately 12, leading to the precipitation of any magnesium ions present as $\text{Mg}(\text{OH})_2$. [1]
- Indicator Addition:
 - Add 5-6 drops of the **thymolphthalexon** indicator solution to the flask. If calcium ions are present, the solution will turn blue.[1]
- Titration:
 - Fill a burette with the standardized 0.01 M EDTA solution.
 - Titrate the prepared water sample with the EDTA solution while continuously swirling the flask.
 - The endpoint is reached when the color of the solution changes from blue to colorless or a faint pink.[1]
- Data Recording and Analysis:
 - Record the volume of EDTA solution used.
 - Repeat the titration at least two more times to ensure concordant results and calculate the average volume of EDTA consumed.[1]
 - The calcium hardness can then be calculated using the following formula:

$$\text{Calcium Hardness (mg/L as CaCO}_3\text{)} = (V_{\text{EDTA}} \times M_{\text{EDTA}} \times 100.09 \text{ g/mol} \times 1000 \text{ mg/g}) / V_{\text{sample}}$$

Where:

- V_{EDTA} = Volume of EDTA solution used in liters
- M_{EDTA} = Molarity of the EDTA solution
- 100.09 g/mol = Molar mass of CaCO_3
- V_{sample} = Volume of the water sample in liters

Data Presentation

The following table presents hypothetical but realistic data from the determination of calcium hardness in a water sample using the protocol described above.

| Replicate | Sample Volume (mL) | Initial Burette Reading (mL) | Final Burette Reading (mL) | Volume of 0.01 M EDTA Used (mL) |
|-----------|--------------------|------------------------------|----------------------------|---------------------------------|
| 1 | 50.0 | 0.10 | 15.20 | 15.10 |
| 2 | 50.0 | 15.20 | 30.25 | 15.05 |
| 3 | 50.0 | 30.25 | 45.35 | 15.10 |
| Average | 15.08 | | | |

Experimental Workflow and Signaling Pathway Visualization

The following diagrams illustrate the logical workflow of the experimental procedure and the chemical signaling pathway of the indicator during titration.

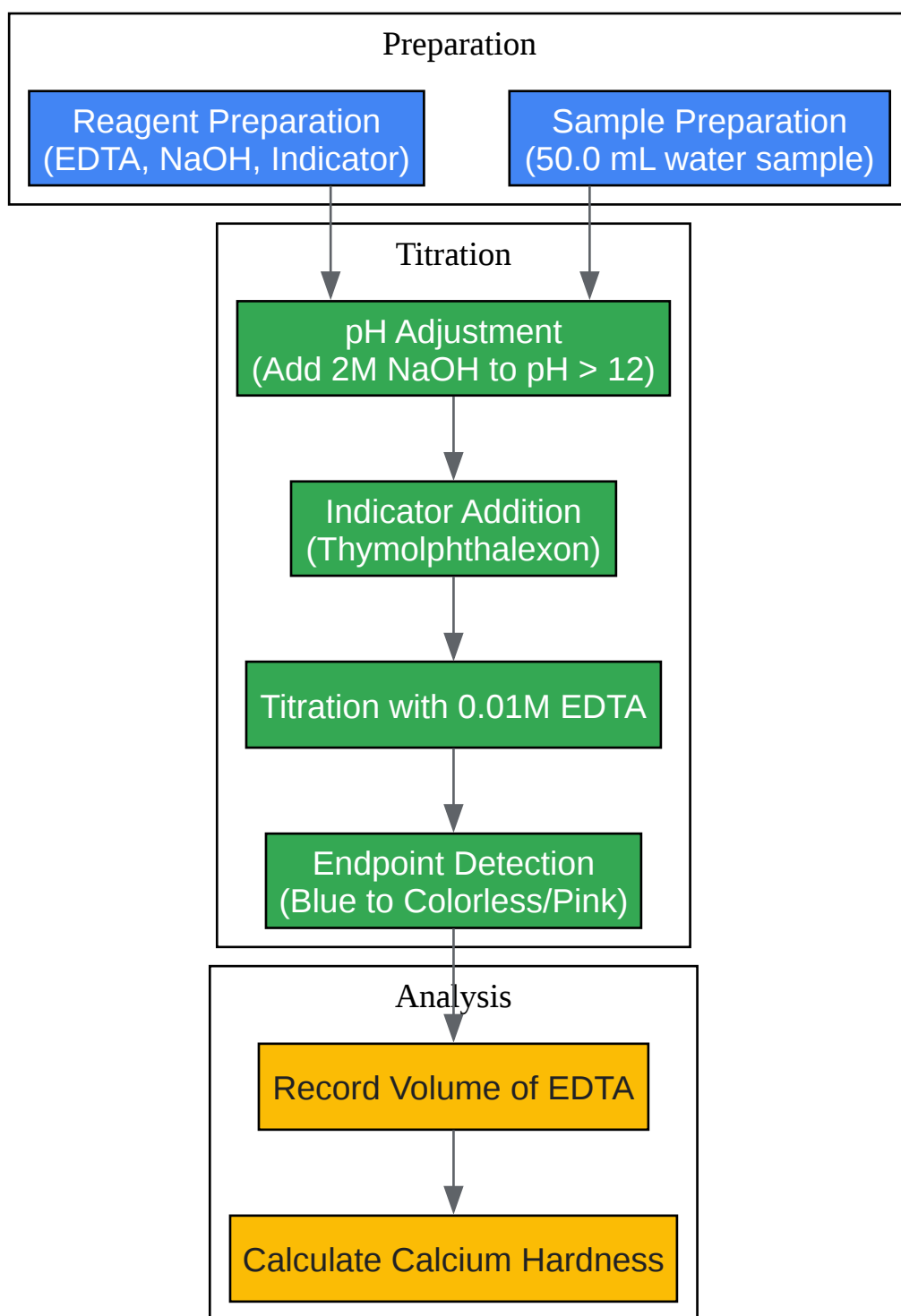

[Click to download full resolution via product page](#)

Caption: Experimental workflow for calcium hardness determination.

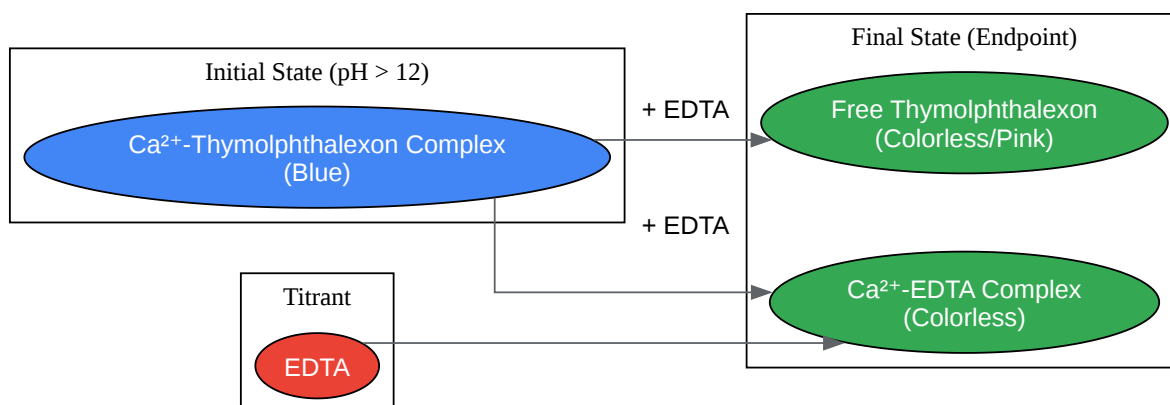

[Click to download full resolution via product page](#)

Caption: Indicator signaling pathway during titration.

Need Custom Synthesis?

BenchChem offers custom synthesis for rare earth carbides and specific isotopic labeling.

Email: info@benchchem.com or [Request Quote Online](#).

References

- 1. [benchchem.com](https://www.benchchem.com) [[benchchem.com](https://www.benchchem.com)]
- 2. [Determination of Hardness of Water](https://staff.buffalostate.edu) [staff.buffalostate.edu]
- 3. rajdhnicollege.ac.in [rajdhnicollege.ac.in]
- 4. [benchchem.com](https://www.benchchem.com) [[benchchem.com](https://www.benchchem.com)]
- 5. cd1.edb.hkedcity.net [cd1.edb.hkedcity.net]
- To cite this document: BenchChem. [Application Notes and Protocols for the Determination of Water Hardness Using Thymolphthalexon]. BenchChem, [2026]. [Online PDF]. Available at: [<https://www.benchchem.com/product/b12406562/docs#application-notes-and-protocols-for-the-determination-of-water-hardness-using-thymolphthalexon>]

Disclaimer & Data Validity:

The information provided in this document is for Research Use Only (RUO) and is strictly not intended for diagnostic or therapeutic procedures. While BenchChem strives to provide accurate protocols, we make no warranties, express or implied, regarding the fitness of this product for every specific experimental setup.

Technical Support: The protocols provided are for reference purposes. Unsure if this reagent suits your experiment?

Need Industrial/Bulk Grade? [Request Custom Synthesis Quote](#)

BenchChem

Our mission is to be the trusted global source of essential and advanced chemicals, empowering scientists and researchers to drive progress in science and industry.

Contact

Address: 3281 E Guasti Rd
Ontario, CA 91761, United States
Phone: (601) 213-4426
Email: info@benchchem.com

[Contact our Ph.D. Support Team for a compatibility check](#)