

Technical Support Center: Refining Cdk8-IN-11 Dosage for Primary Cells

Author: BenchChem Technical Support Team. **Date:** April 2026

Compound of Interest

Compound Name: Cdk8-IN-11

Cat. No.: B12405916

[Get Quote](#)

Welcome to the technical support center for **Cdk8-IN-11**. This resource is designed for researchers, scientists, and drug development professionals to provide guidance on effectively using **Cdk8-IN-11** in primary cell cultures. Here you will find frequently asked questions, troubleshooting guides, and detailed experimental protocols to help you optimize your experiments.

Frequently Asked Questions (FAQs)

Q1: What is **Cdk8-IN-11** and what is its mechanism of action?

A1: **Cdk8-IN-11** is a potent and selective inhibitor of Cyclin-Dependent Kinase 8 (Cdk8) and its close paralog, Cdk19. Cdk8 is a component of the Mediator complex, which plays a crucial role in regulating transcription by RNA Polymerase II. By inhibiting Cdk8/19, **Cdk8-IN-11** can modulate the expression of genes involved in various signaling pathways, including the Wnt/ β -catenin and STAT signaling pathways. For instance, it has been shown to inhibit the phosphorylation of STAT1 at the Ser727 residue.

Q2: What is a recommended starting concentration for **Cdk8-IN-11** in primary cells?

A2: Currently, there is limited specific data on the optimal dosage of **Cdk8-IN-11** for various primary cell types. Primary cells are often more sensitive to kinase inhibitors than immortalized cell lines. Therefore, it is crucial to perform a dose-response experiment to determine the optimal concentration for your specific primary cell type and experimental endpoint.

Based on studies with other Cdk8/19 inhibitors in primary cells, a starting range of 10 nM to 100 nM is a reasonable starting point for your dose-response curve. For example, the Cdk8/19 inhibitor CCT251921 has been used in the 10-50 nM range in primary T cells, while another inhibitor, cortistatin A, showed maximal effects at 10 nM in primary macrophages and was used at 100 nM in cord blood-derived megakaryocytes.

Q3: How does the IC50 of **Cdk8-IN-11** in cancer cell lines translate to primary cells?

A3: The IC50 values of **Cdk8-IN-11** determined in cancer cell lines can serve as a preliminary reference. However, these values should be interpreted with caution when working with primary cells. Differences in cell permeability, metabolism, and the specific signaling pathways active in primary cells can significantly alter the effective concentration. It is essential to empirically determine the IC50 for your primary cell type of interest.

Q4: What are the key signaling pathways affected by **Cdk8-IN-11**?

A4: Cdk8 is a key regulator of multiple signaling pathways critical for cell proliferation, differentiation, and immune responses. The primary pathways affected by **Cdk8-IN-11** include:

- Wnt/ β -catenin pathway: Cdk8 is known to be an oncogene in certain cancers by promoting β -catenin-dependent transcription.
- STAT signaling: Cdk8 can phosphorylate STAT1, STAT3, and STAT5, thereby modulating cytokine responses.
- TGF- β signaling: Cdk8 can enhance the transcriptional activity of SMADs.
- Notch signaling: Cdk8 is involved in the turnover of the Notch intracellular domain.
- p53 pathway: Cdk8 can act as a coactivator in the p53 transcriptional program.

Troubleshooting Guide

Issue	Potential Cause	Recommended Solution
High Cell Death/Toxicity at Low Concentrations	Primary cells are highly sensitive to the inhibitor or solvent (e.g., DMSO).	<ul style="list-style-type: none"> • Perform a dose-response curve starting from a very low concentration (e.g., 1 nM). • Lower the final concentration of the solvent in the culture medium. • Reduce the treatment duration. • Ensure the health and viability of primary cells before starting the experiment.
No Observable Effect at Expected Concentrations	<ul style="list-style-type: none"> • The target pathway may not be active in the specific primary cell type. • Insufficient treatment duration. • The inhibitor may be degraded or metabolized. 	<ul style="list-style-type: none"> • Confirm the expression and activity of Cdk8 and the target pathway in your primary cells. • Perform a time-course experiment to determine the optimal treatment duration. • Increase the concentration of Cdk8-IN-11 based on dose-response data. • Replenish the media with fresh inhibitor during long-term experiments.
Inconsistent Results Between Experiments	<ul style="list-style-type: none"> • Variation in primary cell isolation and culture. • Passage number of primary cells (if applicable). • Inconsistent inhibitor preparation. 	<ul style="list-style-type: none"> • Standardize the protocol for primary cell isolation and culture. • Use cells from the same passage number for comparisons. • Prepare fresh stock solutions of Cdk8-IN-11 and aliquot for single use to avoid freeze-thaw cycles.
Unexpected Off-Target Effects	Cdk8-IN-11 may inhibit other kinases or cellular processes at higher concentrations.	<ul style="list-style-type: none"> • Use the lowest effective concentration determined from your dose-response curve. • If possible, validate key findings using a structurally different

Cdk8/19 inhibitor or a genetic approach (e.g., siRNA/shRNA).

Quantitative Data Summary

Table 1: Reported IC50 Values of **Cdk8-IN-11** in Cancer Cell Lines

Cell Line	Cancer Type	IC50 (nM)
HCT-116	Colon Cancer	1.2
HHT-29		0.7
SW480	Colon Cancer	2.4
CT-26	Colon Cancer	5.5
GES-1		62.7

Data is provided as a reference and may not be directly applicable to primary cells.

Table 2: Example Dosing of Other Cdk8/19 Inhibitors in Primary Cells

Inhibitor	Primary Cell Type	Concentration Range	Observed Effect
CCT251921	Primary T cells	10 - 50 nM	Increased Foxp3+ Treg cell population
Cortistatin A	Cord blood-derived megakaryocytes	100 nM	Decreased cell expansion
Cortistatin A	Peritoneal macrophages	10 nM (maximal effect)	Inhibition of inflammatory mediator production

Experimental Protocols

Protocol 1: Determining the Optimal Dosage of Cdk8-IN-11 in Primary Cells using a Dose-Response Curve and Viability Assay

This protocol outlines a general method to determine the half-maximal inhibitory concentration (IC₅₀) of **Cdk8-IN-11** in adherent primary cells.

Materials:

- Primary cells of interest
- Complete culture medium for the primary cells
- **Cdk8-IN-11**
- DMSO (or other appropriate solvent)
- 96-well clear-bottom black plates (for fluorescence/luminescence assays) or clear plates (for colorimetric assays)
- Cell viability reagent (e.g., CellTiter-Glo®, PrestoBlue™, MTT)
- Multichannel pipette
- Plate reader

Procedure:

- Cell Seeding:
 - Harvest and count your primary cells.
 - Seed the cells in a 96-well plate at the recommended density for your cell type. Allow the cells to adhere and recover for 24 hours. The optimal seeding density should be determined empirically to ensure cells are in a logarithmic growth phase at the end of the assay.
- Preparation of **Cdk8-IN-11** Dilutions:

- Prepare a 10 mM stock solution of **Cdk8-IN-11** in DMSO.
- Perform serial dilutions of the stock solution in complete culture medium to create a range of concentrations (e.g., 1 nM, 10 nM, 100 nM, 1 μ M, 10 μ M). It is recommended to perform a wide range of dilutions in the initial experiment. Also, prepare a vehicle control (medium with the same final concentration of DMSO as the highest inhibitor concentration).
- Cell Treatment:
 - Carefully remove the medium from the wells.
 - Add 100 μ L of the prepared **Cdk8-IN-11** dilutions or vehicle control to the respective wells. It is recommended to have at least three technical replicates for each condition.
- Incubation:
 - Incubate the plate for a duration relevant to your experimental question (e.g., 24, 48, or 72 hours).
- Cell Viability Assay:
 - Following incubation, perform a cell viability assay according to the manufacturer's instructions.
- Data Analysis:
 - Measure the signal (luminescence, fluorescence, or absorbance) using a plate reader.
 - Normalize the data to the vehicle control (set as 100% viability).
 - Plot the normalized viability against the log of the inhibitor concentration.
 - Use a non-linear regression analysis (e.g., sigmoidal dose-response curve) to determine the IC50 value.

Mandatory Visualizations

Cdk8 Signaling Pathways

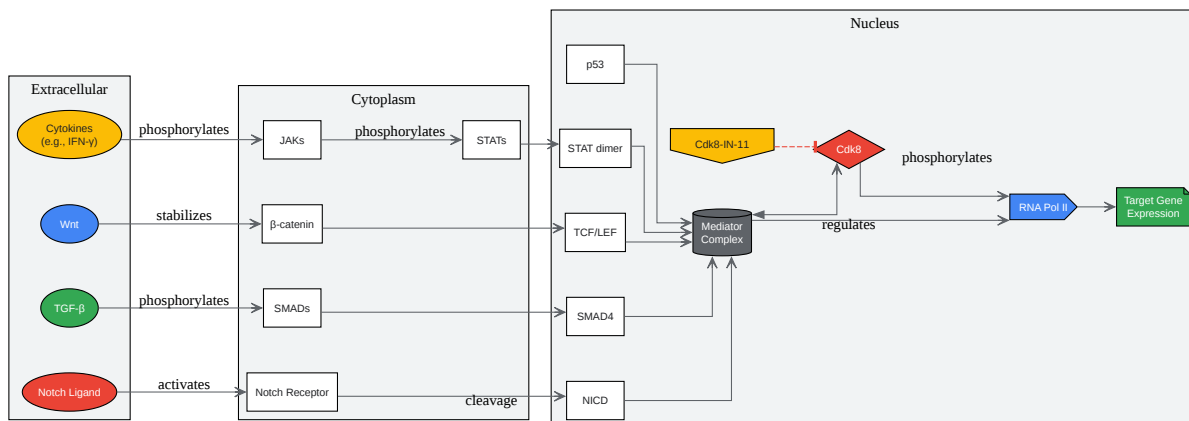

[Click to download full resolution via product page](#)

Caption: Overview of major signaling pathways regulated by Cdk8.

Experimental Workflow for Determining Optimal Cdk8-IN-11 Dosage

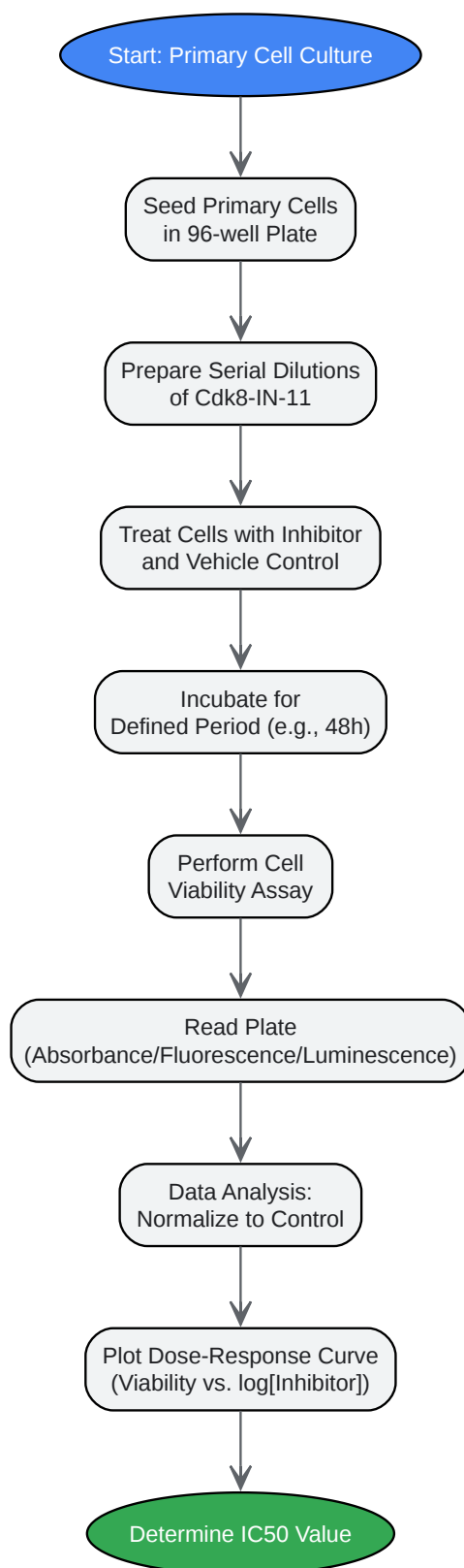

[Click to download full resolution via product page](#)

Caption: Step-by-step workflow for dose-response analysis in primary cells.

Logical Relationship for Troubleshooting High Toxicity

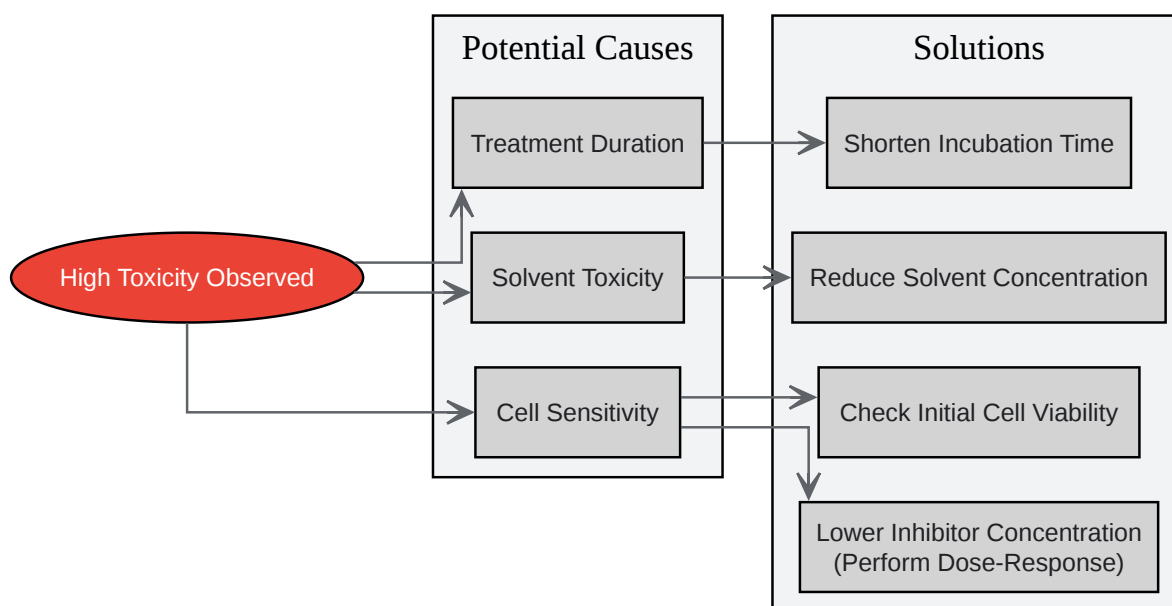

[Click to download full resolution via product page](#)

Caption: Troubleshooting logic for high toxicity in primary cell experiments.

- To cite this document: BenchChem. [Technical Support Center: Refining Cdk8-IN-11 Dosage for Primary Cells]. BenchChem, [2026]. [Online PDF]. Available at: [\[https://www.benchchem.com/product/b12405916/docs#technical-support-center-refining-cdk8-in-11-dosage-for-primary-cells\]](https://www.benchchem.com/product/b12405916/docs#technical-support-center-refining-cdk8-in-11-dosage-for-primary-cells)

Disclaimer & Data Validity:

The information provided in this document is for Research Use Only (RUO) and is strictly not intended for diagnostic or therapeutic procedures. While BenchChem strives to provide accurate protocols, we make no warranties, express or implied, regarding the fitness of this product for every specific experimental setup.

Technical Support: The protocols provided are for reference purposes. Unsure if this reagent suits your experiment?

Need Industrial/Bulk Grade? [Request Custom Synthesis Quote](#)

BenchChem

Our mission is to be the trusted global source of essential and advanced chemicals, empowering scientists and researchers to drive progress in science and industry.

Contact

Address: 3281 E Guasti Rd

Ontario, CA 91761, United States

Phone: (601) 213-4426

Email: info@benchchem.com

[Contact our Ph.D. Support Team for a compatibility check](#)