

Technical Support Center: DMX-129 Based Assays

Author: BenchChem Technical Support Team. **Date:** April 2026

Compound of Interest

Compound Name: DMX-129
Cat. No.: B12405867

[Get Quote](#)

Important Note on "**DMX-129**": Public scientific databases and commercial supplier catalogs do not contain information on a compound or assay reagent with the designation "**DMX-129**." This name may refer to a proprietary, in-house compound, a novel molecule not yet in the public domain, or a potential typographical error.

The following technical support guide is a hypothetical example created to demonstrate the expected format and content. For this guide, "**DMX-129**" is treated as a fictional, ATP-competitive inhibitor of the Epidermal Growth Factor Receptor (EGFR) kinase. The principles, troubleshooting steps, and protocols are based on common practices for kinase inhibitor assays and may serve as a general reference. For accurate support, please provide the specific target and assay modality for your compound of interest.

Frequently Asked Questions (FAQs)

Q1: What is the mechanism of action for **DMX-129**?

A1: In this hypothetical model, **DMX-129** is a potent, reversible, ATP-competitive inhibitor of the EGFR tyrosine kinase. It binds to the ATP-binding pocket of the EGFR kinase domain, preventing the phosphorylation of downstream substrates and thereby inhibiting the entire signaling cascade.[1]

Q2: Which assay format is recommended for screening **DMX-129** and similar compounds?

A2: A fluorescence polarization (FP) based assay is a robust and common method for screening kinase inhibitors like **DMX-129**.^[2] This homogeneous assay format, which requires no wash steps, measures the displacement of a fluorescently labeled tracer from the kinase's ATP-binding site, making it suitable for high-throughput screening.^[3]

Q3: Why are my IC₅₀ values for **DMX-129** different from those reported in other publications or by other labs?

A3: IC₅₀ values are highly dependent on experimental conditions.^[4] Discrepancies can arise from differences in:

- **ATP Concentration:** In an ATP-competitive assay, a higher ATP concentration will require a higher concentration of the inhibitor to achieve 50% inhibition, leading to a larger apparent IC₅₀ value.^[4]
- **Enzyme and Substrate Concentration:** Variations in the amounts of kinase and substrate can alter the reaction kinetics and inhibitor potency.
- **Assay Format:** Different assay technologies (e.g., FP vs. FRET vs. luminescence-based) can yield different IC₅₀ values.
- **Incubation Time:** For time-dependent inhibitors, the IC₅₀ can change with pre-incubation times.^[5]
- **Buffer Components:** The presence of detergents, DMSO concentration, and other additives can affect enzyme activity and compound behavior.

Q4: Can I use **DMX-129** in cell-based assays?

A4: Yes, after determining its potency in biochemical assays, the next step is to evaluate its efficacy in a cellular context. However, a compound potent in a biochemical assay may not be active in cells due to poor membrane permeability, efflux by cellular transporters, or rapid metabolism.^[6] Cell-based assays, such as monitoring the phosphorylation of downstream targets like ERK or AKT, are crucial for validating the inhibitor's biological effect.

Troubleshooting Guide

Problem	Possible Causes	Recommended Solutions
High Signal in Negative Controls (No Inhibitor)	<p>1. Contaminated Reagents: Buffers, enzyme, or tracer may be contaminated. 2. High Background Fluorescence: Assay plate or media components (e.g., phenol red) may be autofluorescent.[7] 3. Non-specific Binding: The fluorescent tracer may be binding to the wells of the microplate.[8]</p>	<p>1. Use fresh, sterile reagents. Filter-sterilize buffers. 2. Use black, opaque plates for fluorescence assays. Measure in a buffer like PBS if media is the issue.[7] 3. Use non-binding surface (NBS) or low-binding microplates. Consider adding a small amount of a non-ionic detergent (e.g., 0.01% Tween-20) to the assay buffer.[8]</p>
Low Signal or Small Assay Window (Z'-factor < 0.5)	<p>1. Inactive Enzyme: The kinase may have lost activity due to improper storage or handling. 2. Suboptimal Reagent Concentrations: Concentrations of the kinase or tracer may not be optimal. 3. Incorrect Filter Settings: The plate reader's excitation and emission wavelengths may not match the fluorophore. 4. Fluorescence Quenching: Components in the buffer or the compound itself could be quenching the fluorescent signal.</p>	<p>1. Aliquot the enzyme upon receipt and store at -80°C. Avoid repeated freeze-thaw cycles. 2. Perform a titration of both the kinase and the tracer to determine the optimal concentrations that provide a robust signal.[9] 3. Verify the reader settings match the spectral properties of your fluorescent tracer. 4. Check for compound interference by running a control plate without the enzyme.</p>
High Variability Between Replicate Wells	<p>1. Pipetting Errors: Inaccurate or inconsistent dispensing of reagents.[10] 2. Incomplete Mixing: Reagents, especially the inhibitor, may not be fully mixed in the well. 3. Edge Effects: Evaporation from the</p>	<p>1. Calibrate pipettes regularly. Use reverse pipetting for viscous solutions. Pre-wet tips. [10] 2. Ensure thorough mixing after adding each reagent, for example, by shaking the plate for 30 seconds. 3. Avoid using</p>

outer wells of the plate can concentrate reagents.[10] 4. Compound Precipitation: The inhibitor may be precipitating out of solution at higher concentrations.

the outer wells for samples. Fill them with PBS or water to create a humidity barrier.[10] 4. Check the solubility of your compound in the final assay buffer. The final DMSO concentration should typically be kept below 1%.

IC50 Curve Does Not Reach 100% Inhibition

1. Compound is not inhibiting the target. 2. Active, Fluorescent Contaminant: An impurity in the compound stock may be fluorescent. 3. Irreversible Inhibition: The inhibitor may bind irreversibly, but the assay was not run to completion.

1. Confirm the identity and purity of the compound. Test a known EGFR inhibitor as a positive control. 2. Analyze the compound by HPLC to check for fluorescent impurities. 3. For suspected irreversible inhibitors, a continuous assay format is more appropriate than an endpoint reading.[5]

Experimental Protocols & Data

Protocol: EGFR Kinase Assay using Fluorescence Polarization

This protocol describes a competitive binding assay to determine the IC50 of **DMX-129** against EGFR kinase.

1. Reagent Preparation:

- Assay Buffer: 50 mM HEPES (pH 7.5), 10 mM MgCl₂, 1 mM EGTA, 2 mM DTT, 0.01% Tween-20.
- EGFR Enzyme: Recombinant human EGFR (catalytic domain), diluted to 2X final concentration in Assay Buffer.
- Fluorescent Tracer: A fluorescein-labeled, ATP-competitive ligand for EGFR, diluted to 2X final concentration in Assay Buffer.

- **DMX-129** Compound: Prepare a 10 mM stock in 100% DMSO. Create a serial dilution series (e.g., 11 points, 1:3 dilution) in DMSO. Then, create a 100X intermediate dilution plate in Assay Buffer.

2. Assay Procedure (384-well plate):

- Add 10 μ L of Assay Buffer to all wells.
- Add 1 μ L of the **DMX-129** serial dilution (or DMSO for controls) to the appropriate wells.
- Add 5 μ L of the 2X EGFR enzyme solution to all wells except the "no enzyme" controls.
- Mix the plate on a plate shaker for 1 minute.
- Incubate for 60 minutes at room temperature, protected from light.
- Add 5 μ L of the 2X Fluorescent Tracer solution to all wells.
- Mix the plate on a plate shaker for 1 minute.
- Incubate for another 30 minutes at room temperature, protected from light.
- Read the plate on a suitable plate reader (Excitation: 485 nm, Emission: 535 nm), measuring both parallel and perpendicular fluorescence polarization.

3. Data Analysis:

- Convert fluorescence intensity to millipolarization (mP) units.
- Normalize the data using the high (DMSO only) and low (potent control inhibitor) controls.
- Plot the normalized response vs. the log of the inhibitor concentration and fit the data to a four-parameter logistic model to determine the IC50.

Quantitative Data Summary

Parameter	DMX-129 (Hypothetical)	Gefitinib (Control)	Notes
Biochemical IC50 (EGFR)	15 nM	25 nM	Determined via FP assay with 10 μ M ATP.
Cellular IC50 (A431 cells)	120 nM	150 nM	Measured by inhibition of EGF-stimulated p-ERK.
Kinase Selectivity (vs. VEGFR2)	> 100-fold	~50-fold	Ratio of VEGFR2 IC50 / EGFR IC50.
Assay Z'-factor	0.85	0.88	Indicates a robust and high-quality assay.

Visualizations

Signaling Pathway Diagram

The diagram below illustrates the simplified EGFR signaling pathway, which is inhibited by **DMX-129**. Upon ligand (e.g., EGF) binding, EGFR dimerizes and autophosphorylates, creating docking sites for adaptor proteins like GRB2.^{[11][12]} This initiates downstream cascades, including the RAS-RAF-MEK-ERK (MAPK) pathway, which promotes cell proliferation.^{[1][13]}

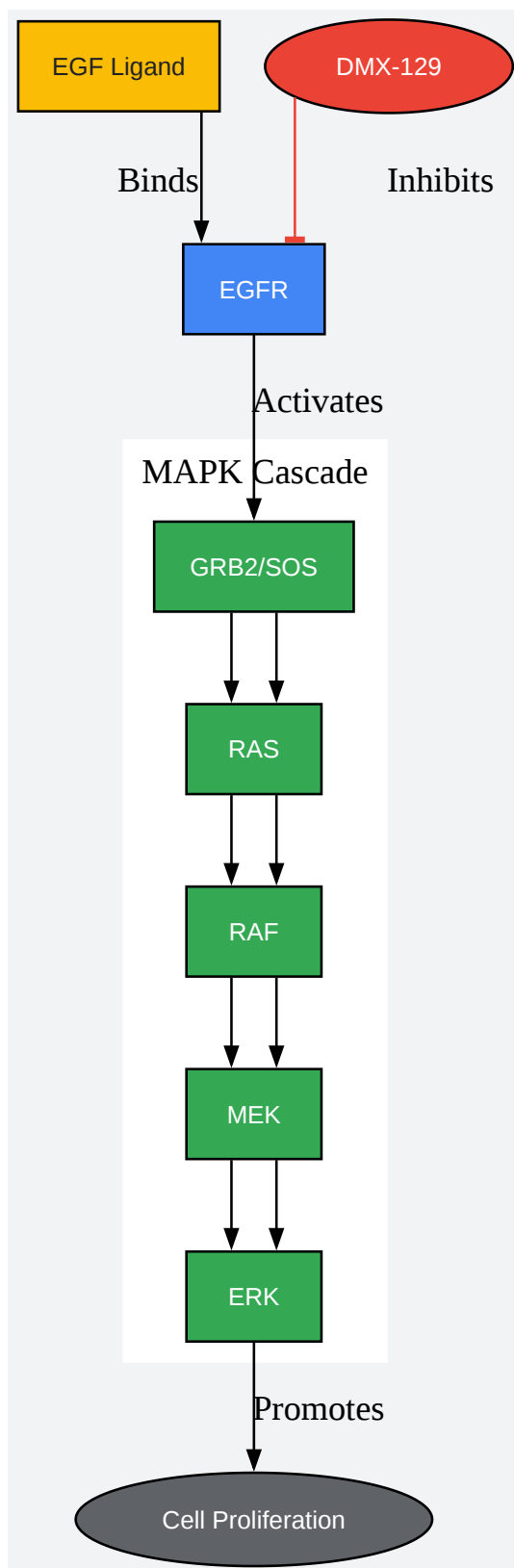

[Click to download full resolution via product page](#)

Caption: Simplified EGFR signaling cascade inhibited by **DMX-129**.

Experimental Workflow Diagram

The following workflow outlines the key steps for determining the IC50 value of **DMX-129** in the fluorescence polarization assay described.



[Click to download full resolution via product page](#)

Caption: Workflow for an EGFR fluorescence polarization assay.

Need Custom Synthesis?

BenchChem offers custom synthesis for rare earth carbides and specific isotopic labeling.

Email: info@benchchem.com or [Request Quote Online](#).

References

- [1. ClinPGx \[clinpgx.org\]](#)
- [2. bpsbioscience.com \[bpsbioscience.com\]](#)
- [3. youtube.com \[youtube.com\]](#)
- [4. Assessing the Inhibitory Potential of Kinase Inhibitors In Vitro: Major Pitfalls and Suggestions for Improving Comparability of Data Using CK1 Inhibitors as an Example - PMC \[pmc.ncbi.nlm.nih.gov\]](#)
- [5. assayquant.com \[assayquant.com\]](#)
- [6. reactionbiology.com \[reactionbiology.com\]](#)
- [7. bitesizebio.com \[bitesizebio.com\]](#)
- [8. In Solution Assays: Fluorescence Polarization - Glycopedia \[glycopedia.eu\]](#)
- [9. Establishing and optimizing a fluorescence polarization assay \[moleculardevices.com\]](#)
- [10. benchchem.com \[benchchem.com\]](#)

- [11. A comprehensive pathway map of epidermal growth factor receptor signaling - PMC \[pmc.ncbi.nlm.nih.gov\]](#)
- [12. lifesciences.danaher.com \[lifesciences.danaher.com\]](#)
- [13. creative-diagnostics.com \[creative-diagnostics.com\]](#)
- To cite this document: BenchChem. [Technical Support Center: DMX-129 Based Assays]. BenchChem, [2026]. [Online PDF]. Available at: [\[https://www.benchchem.com/product/b12405867/docs#technical-support-center-dmx-129-based-assays\]](https://www.benchchem.com/product/b12405867/docs#technical-support-center-dmx-129-based-assays)

Disclaimer & Data Validity:

The information provided in this document is for Research Use Only (RUO) and is strictly not intended for diagnostic or therapeutic procedures. While BenchChem strives to provide accurate protocols, we make no warranties, express or implied, regarding the fitness of this product for every specific experimental setup.

Technical Support: The protocols provided are for reference purposes. Unsure if this reagent suits your experiment?

Need Industrial/Bulk Grade? [Request Custom Synthesis Quote](#)

BenchChem

Our mission is to be the trusted global source of essential and advanced chemicals, empowering scientists and researchers to drive progress in science and industry.

Contact

Address: 3281 E Guasti Rd
Ontario, CA 91761, United States
Phone: (601) 213-4426
Email: info@benchchem.com

[Contact our Ph.D. Support Team for a compatibility check](#)

