

Application Notes and Protocols for Studying Inflammatory Responses In Vitro

Author: BenchChem Technical Support Team. **Date:** April 2026

Compound of Interest

Compound Name: EUK-118
Cat. No.: B12405715

[Get Quote](#)

Note to the Reader: The initial request specified "EUK-118." Based on a comprehensive review of the scientific literature, it is highly probable that this was a typographical error and the intended compound of interest is EUK-134, a well-researched synthetic superoxide dismutase (SOD) and catalase mimetic. This document will focus on EUK-134. For comparative purposes and to provide a broader context, we will also include information on another anti-inflammatory compound, LQB-118, a pterocarpanquinone.

Part 1: EUK-134 - A Synthetic SOD/Catalase Mimetic for Inflammation Research

Application Notes

EUK-134 is a salen-manganese complex that acts as a synthetic mimetic of two key antioxidant enzymes: superoxide dismutase (SOD) and catalase.^{[1][2]} In the context of inflammation, reactive oxygen species (ROS) are not only byproducts of metabolic processes but also act as signaling molecules that can amplify the inflammatory cascade. EUK-134's ability to catalytically scavenge superoxide radicals and hydrogen peroxide makes it a potent tool for investigating the role of oxidative stress in inflammation.^{[1][2][3]}

Mechanism of Action: Inflammation is often associated with the activation of transcription factors such as NF- κ B and AP-1, which regulate the expression of pro-inflammatory genes.[2] The signaling pathways leading to the activation of these transcription factors, including the mitogen-activated protein kinase (MAPK) pathways (ERK, JNK, and p38), are redox-sensitive.[1][4] By reducing the cellular ROS burden, EUK-134 can inhibit the activation of these pathways, thereby downregulating the production of pro-inflammatory mediators.[1][2] In vitro studies have demonstrated that pre-treatment with EUK-134 inhibits the UVB-induced activation of ERK, JNK, and p38 MAPK pathways.[1] It has also been shown to prevent the induction of NF- κ B elicited by systemic administration of kainic acid in in vivo models.[2]

Quantitative Data for EUK-134

Cell Line/Model	Inflammatory Stimulus	EUK-134 Concentration	Observed Effect	Reference
Primary Human Keratinocytes	UVB Irradiation	Concentration-dependent	Significantly lower accumulation of p53 protein.	[1]
Primary Human Keratinocytes	UVB Irradiation	Not specified	Inhibited activation of ERK, JNK, and p38 MAPK pathways.	[1]
Rat Limbic System (in vivo)	Kainic Acid	Not specified	Significant reduction in NF- κ B and AP-1 binding activity.	[2]
Human Neuroblastoma SK-N-MC	H2O2	Dose-dependent	Lowered phosphorylation of MAPKs.	[4]
Human Skin (in vivo)	UVA Irradiation	0.01-0.1% (topical)	Reduced level of skin surface lipid peroxidation.	[5]

Experimental Protocols

1. General Cell Culture and Induction of Inflammation with LPS

- Cell Line: RAW 264.7 murine macrophage cell line.
- Culture Medium: Dulbecco's Modified Eagle's Medium (DMEM) supplemented with 10% Fetal Bovine Serum (FBS) and 1% penicillin-streptomycin.
- Culture Conditions: 37°C, 5% CO₂, humidified atmosphere.
- Protocol:
 - Seed RAW 264.7 cells in 24-well plates at a density of 1×10^6 cells/mL and allow them to adhere for 24 hours.[6]
 - Pre-treat the cells with various concentrations of EUK-134 for 1 hour.
 - Induce inflammation by adding Lipopolysaccharide (LPS) to a final concentration of 1 µg/mL.[7]
 - Incubate for the desired time period (e.g., 24 hours for cytokine and nitric oxide measurements).

2. Measurement of Nitric Oxide (NO) Production using Griess Assay

- Principle: Nitric oxide is a short-lived molecule that is rapidly converted to nitrite (NO₂⁻) in culture medium. The Griess reagent reacts with nitrite to form a colored azo compound, the absorbance of which can be measured spectrophotometrically.[8][9]
- Protocol:
 - After the incubation period with LPS and EUK-134, collect 100 µL of the cell culture supernatant.
 - In a 96-well plate, mix 100 µL of the supernatant with 100 µL of Griess reagent (a mixture of 1% sulfanilamide in 5% phosphoric acid and 0.1% N-(1-naphthyl)ethylenediamine dihydrochloride).[7][10]

- Incubate at room temperature for 10 minutes, protected from light.
- Measure the absorbance at 540 nm using a microplate reader.^{[7][9]}
- Quantify the nitrite concentration by comparing the absorbance to a standard curve of sodium nitrite.

3. Measurement of Cytokine Production by ELISA

- Principle: Enzyme-Linked Immunosorbent Assay (ELISA) is used to quantify the concentration of specific cytokines (e.g., TNF- α , IL-6, IL-1 β) in the cell culture supernatant.
- Protocol:
 - Collect the cell culture supernatant after treatment with LPS and EUK-134.
 - Use a commercial ELISA kit for the specific cytokine of interest.
 - Follow the manufacturer's instructions for coating the plate with capture antibody, adding samples and standards, adding the detection antibody, adding the enzyme conjugate, and finally adding the substrate.
 - Measure the absorbance at the appropriate wavelength using a microplate reader.
 - Calculate the cytokine concentration based on the standard curve.

4. Western Blot for MAPK and NF- κ B Pathway Proteins

- Principle: Western blotting is used to detect the levels of total and phosphorylated proteins in the MAPK and NF- κ B signaling pathways.
- Protocol:
 - After a shorter incubation period with LPS and EUK-134 (e.g., 30 minutes for phosphorylation events), lyse the cells to extract total protein.
 - Determine the protein concentration using a BCA or Bradford assay.

- Separate the proteins by SDS-PAGE and transfer them to a PVDF or nitrocellulose membrane.
- Block the membrane and then incubate with primary antibodies against total and phosphorylated forms of p38, JNK, ERK, and I κ B α .
- Incubate with a horseradish peroxidase (HRP)-conjugated secondary antibody.
- Detect the protein bands using an enhanced chemiluminescence (ECL) substrate and an imaging system.

Visualizations

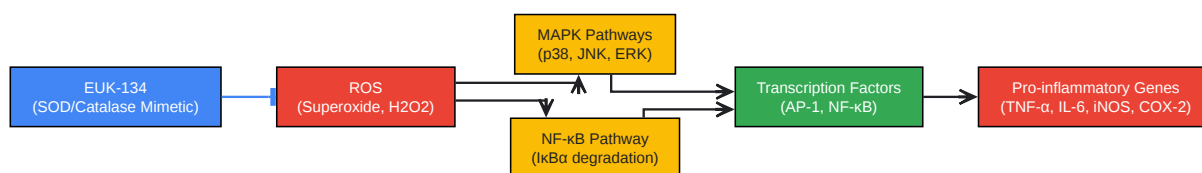

[Click to download full resolution via product page](#)

Caption: Mechanism of action of EUK-134 in mitigating inflammation.

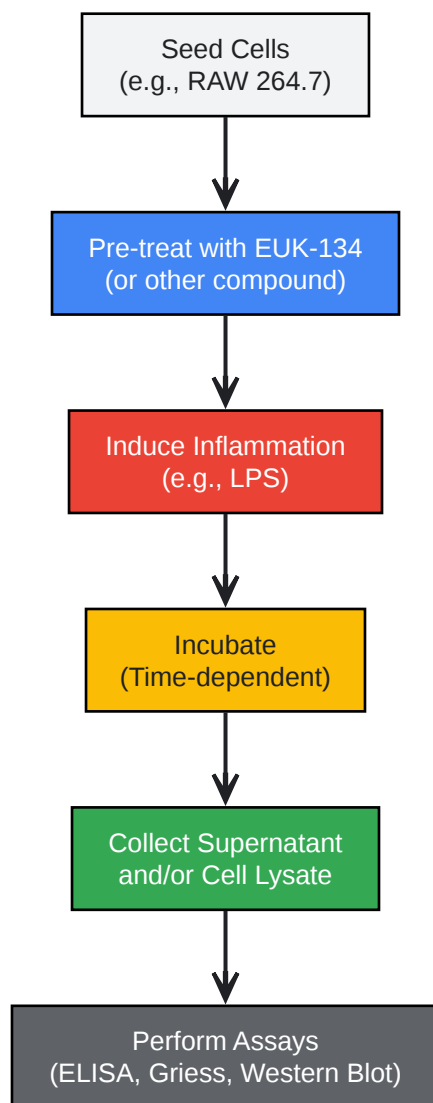

[Click to download full resolution via product page](#)

Caption: General workflow for in vitro anti-inflammatory compound screening.

Part 2: LQB-118 - A Pterocarpanquinone for Inflammation Research

Application Notes

LQB-118 is a synthetic pterocarpanquinone that has demonstrated anti-inflammatory properties in vitro and in vivo.[11][12][13] Its mechanism of action involves the modulation of key inflammatory signaling pathways, leading to a reduction in the production of pro-inflammatory cytokines.[11][14]

Mechanism of Action: LQB-118 has been shown to inhibit inflammation induced by zymosan, a component of the yeast cell wall.[\[11\]](#) This inhibition is associated with a reduction in the expression of Toll-like receptor 2 (TLR2) and the phosphorylation of p38 MAPK.[\[11\]](#) Furthermore, LQB-118 can also modulate the NF- κ B signaling pathway.[\[14\]](#)[\[15\]](#) By targeting these upstream signaling components, LQB-118 effectively reduces the production of pro-inflammatory cytokines such as TNF- α , IL-1 β , and IL-6.[\[11\]](#) Recent studies also suggest that LQB-118 can modulate macrophage phagocytosis and inhibit mTOR/NF- κ B signaling.[\[14\]](#)

Quantitative Data for LQB-118

Cell Line/Model	Inflammatory Stimulus	LQB-118 Concentration	Observed Effect	Reference
Murine Peritoneal Macrophages	Zymosan	5 μ M	Reduction in phagocytosis of zymosan particles.	[14]
Murine Peritoneal Macrophages	Zymosan	5 μ M	Decreased levels of ROS and NO.	[14]
Murine Peritoneal Macrophages	Zymosan	Not specified	Reduced cytokine levels (TNF- α , IL-1 β , IL-6).	[11]
Murine Peritoneal Macrophages	Zymosan	Not specified	Reduced CD69 expression and p38 phosphorylation.	[11]
C57BL/6 Mice (in vivo)	LPS	10 mg/kg	Reduced neutrophil infiltration in the lungs.	[12]
C57BL/6 Mice (in vivo)	LPS	10 mg/kg	Pronounced inhibitory effect on TNF- α release.	[12]

Experimental Protocols

1. Isolation and Culture of Murine Peritoneal Macrophages

- Protocol:
 - Elicit macrophages by intraperitoneal injection of 3% thioglycollate into mice.

- After 3-4 days, euthanize the mice and perform a peritoneal lavage with sterile PBS.
- Collect the peritoneal fluid and centrifuge to pellet the cells.
- Resuspend the cells in RPMI-1640 medium supplemented with 10% FBS and 1% penicillin-streptomycin.
- Plate the cells and allow them to adhere for 2-4 hours.
- Wash away non-adherent cells to obtain a pure macrophage culture.

2. Induction of Inflammation with Zymosan

- Protocol:
 - Culture the peritoneal macrophages as described above.
 - Pre-treat the cells with LQB-118 at the desired concentrations for 1 hour.
 - Add zymosan to the culture medium at a concentration of 10 µg/mL to induce inflammation.[\[16\]](#)
 - Incubate for the appropriate time for the desired readout (e.g., 4 hours for cytokine measurement).[\[17\]](#)

3. Measurement of Cytokine Production and Signaling Pathway Activation

- Follow the protocols for ELISA and Western Blot as described for EUK-134, using antibodies specific for the cytokines (TNF- α , IL-1 β , IL-6) and signaling proteins (total and phosphorylated p38, I κ B α) of interest.

Visualizations

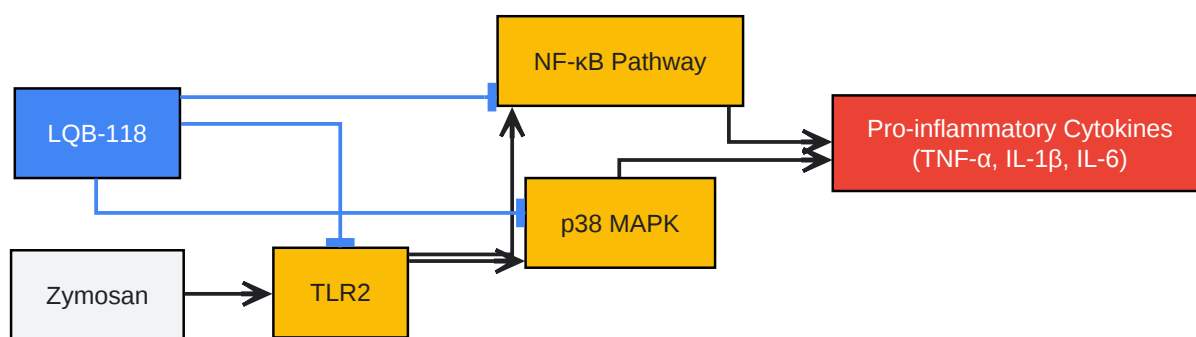

[Click to download full resolution via product page](#)

Caption: Mechanism of action of LQB-118 in inhibiting zymosan-induced inflammation.

Need Custom Synthesis?

BenchChem offers custom synthesis for rare earth carbides and specific isotopic labeling.

Email: info@benchchem.com or [Request Quote Online](#).

References

- 1. A synthetic superoxide dismutase/catalase mimetic (EUK-134) inhibits membrane-damage-induced activation of mitogen-activated protein kinase pathways and reduces p53 accumulation in ultraviolet B-exposed primary human keratinocytes - PubMed [pubmed.ncbi.nlm.nih.gov]
- 2. EUK-134, a synthetic superoxide dismutase and catalase mimetic, prevents oxidative stress and attenuates kainate-induced neuropathology - PMC [pmc.ncbi.nlm.nih.gov]
- 3. Use of the synthetic superoxide dismutase/catalase mimetic EUK-134 to compensate for seasonal antioxidant deficiency by reducing pre-existing lipid peroxides at the human skin surface - PubMed [pubmed.ncbi.nlm.nih.gov]
- 4. Modulation of H₂O₂-induced mitogen-activated protein kinases activation and cell death in SK-N-MC cells by EUK134, a salen derivative - PubMed [pubmed.ncbi.nlm.nih.gov]
- 5. Pursuing the Elixir of Life: In Vivo Antioxidative Effects of Manganosalen Complexes [mdpi.com]
- 6. mdpi.com [mdpi.com]
- 7. Anti-Inflammatory Activity and ROS Regulation Effect of Sinapaldehyde in LPS-Stimulated RAW 264.7 Macrophages - PMC [pmc.ncbi.nlm.nih.gov]

- [8. sciencellonline.com \[sciencellonline.com\]](https://www.sciencellonline.com)
- [9. sigmaaldrich.com \[sigmaaldrich.com\]](https://www.sigmaaldrich.com)
- [10. Inhibition of nitric oxide production in LPS-stimulated RAW 264.7 cells by stem bark of Ulmus pumila L - PMC \[pmc.ncbi.nlm.nih.gov\]](#)
- [11. The pterocarpanquinone LQB 118 inhibits inflammation triggered by zymosan in vivo and in vitro - PubMed \[pubmed.ncbi.nlm.nih.gov\]](#)
- [12. researchgate.net \[researchgate.net\]](https://www.researchgate.net)
- [13. Anti-inflammatory properties of pterocarpanquinone LQB-118 in mice - PubMed \[pubmed.ncbi.nlm.nih.gov\]](#)
- [14. Immunomodulatory Effects of Pterocarpanquinone LQB-118 in Murine Peritoneal Macrophages - PubMed \[pubmed.ncbi.nlm.nih.gov\]](#)
- [15. researchgate.net \[researchgate.net\]](https://www.researchgate.net)
- [16. The efficacy of zymosan in pro-inflammatory cytokine production by peritoneal macrophages of melanoma-bearing mice | springermedicine.com \[springermedicine.com\]](#)
- [17. Zymosan activates protein kinase A via adenylyl cyclase VII to modulate innate immune responses during inflammation - PMC \[pmc.ncbi.nlm.nih.gov\]](#)
- [To cite this document: BenchChem. \[Application Notes and Protocols for Studying Inflammatory Responses In Vitro\]. BenchChem, \[2026\]. \[Online PDF\]. Available at: \[https://www.benchchem.com/product/b12405715/docs#application-notes-and-protocols-for-studying-inflammatory-responses-in-vitro\]](#)

Disclaimer & Data Validity:

The information provided in this document is for Research Use Only (RUO) and is strictly not intended for diagnostic or therapeutic procedures. While BenchChem strives to provide accurate protocols, we make no warranties, express or implied, regarding the fitness of this product for every specific experimental setup.

Technical Support: The protocols provided are for reference purposes. Unsure if this reagent suits your experiment?

Need Industrial/Bulk Grade? [Request Custom Synthesis Quote](#)

BenchChem

Our mission is to be the trusted global source of essential and advanced chemicals, empowering scientists and researchers to drive progress in science and industry.

Contact

Address: 3281 E Guasti Rd

Ontario, CA 91761, United States

Phone: (601) 213-4426

Email: info@benchchem.com

[Contact our Ph.D. Support Team for a compatibility check](#)