

# Technical Support Center: Post-Biotinylation Purification

**Author:** BenchChem Technical Support Team. **Date:** April 2026

## Compound of Interest

Compound Name: *Biotin-PEG6-Acid*

Cat. No.: *B606146*

[Get Quote](#)

This guide provides researchers, scientists, and drug development professionals with comprehensive troubleshooting and frequently asked questions (FAQs) regarding the removal of excess **Biotin-PEG6-Acid** after a biotinylation reaction.

## Frequently Asked Questions (FAQs)

### Q1: Why is it crucial to remove excess **Biotin-PEG6-Acid** after my reaction?

A1: Removing excess, unreacted **Biotin-PEG6-Acid** is critical for several reasons. High concentrations of free biotin can interfere with downstream applications that rely on the specific binding of the biotinylated molecule to avidin or streptavidin.<sup>[1]</sup> This interference can lead to reduced signal, high background noise, and inaccurate results in assays such as ELISA, Western blotting, and pull-down experiments.<sup>[1][2]</sup> Furthermore, unreacted biotin can occupy the binding sites on streptavidin-coated surfaces or beads, reducing the efficiency of capturing your target molecule.<sup>[1]</sup>

### Q2: What are the most common methods to remove free biotin?

A2: The most widely used methods for removing excess biotinylation reagents are based on the size difference between the small biotin molecule and the much larger target molecule (e.g., a protein or antibody). These techniques include:

- **Dialysis:** A simple and effective method for removing small molecules from larger ones by diffusion across a semi-permeable membrane.[\[3\]](#)
- **Size Exclusion Chromatography (SEC) / Desalting:** This technique, often performed using spin columns or gravity-flow columns, separates molecules based on their size. Larger molecules elute first, while smaller molecules like free biotin are retained longer.
- **Ultrafiltration:** This method uses centrifugal filter units with a specific molecular weight cutoff (MWCO) membrane to retain the larger biotinylated molecule while allowing the smaller, unreacted biotin to pass through.

For smaller biotinylated molecules like peptides, or when higher purity is required, Reverse-Phase High-Performance Liquid Chromatography (RP-HPLC) can be an effective purification method.

### **Q3: How do I choose the best purification method for my experiment?**

A3: The choice of purification method depends on several factors, including the size of your target molecule, the required purity, the sample volume, and the available equipment. The table below provides a comparison to help you decide.

Method	Principle	Typical Sample Volume	Protein Recovery	Time Required	Key Advantages	Potential Drawbacks
Dialysis	Diffusion across a semi-permeable membrane	0.1 mL to several liters	High	4 hours to overnight	Simple, gentle on proteins, scalable	Time-consuming, potential for sample dilution
Size Exclusion Chromatography (Spin Columns)	Separation based on molecular size	10 $\mu$ L to 4 mL	High (often >90%)	< 15 minutes	Fast, high recovery, easy to use	Limited to small sample volumes, potential for some dilution
Ultrafiltration (Spin Filters)	Centrifugation through a MWCO membrane	100 $\mu$ L to 20 mL	Variable, can be high	15-30 minutes	Concentrates the sample, relatively fast	Potential for protein aggregation or sticking to the membrane
Reverse-Phase HPLC	Separation based on hydrophobicity	$\mu$ L to mL scale	Variable	30-60 minutes per run	High purity, can separate isomers	Requires specialized equipment, potential for protein denaturation

## Q4: I'm seeing low recovery of my biotinylated protein after purification. What could be the cause?

A4: Low recovery of your biotinylated protein can be due to several factors:

- **Over-biotinylation:** Attaching too many biotin molecules can lead to protein precipitation and insolubility. It is advisable to keep the labeling stoichiometry low, around 1-2 biotins per protein, unless otherwise optimized.
- **Protein Sticking to Columns or Membranes:** Some proteins can non-specifically bind to the materials of spin columns or ultrafiltration membranes, leading to loss. Using devices made with low-binding materials or pre-treating the membrane with a blocking agent like polyvinylpyrrolidone can help mitigate this.
- **Incorrect Column or Membrane Choice:** Ensure the molecular weight cutoff (MWCO) of your dialysis membrane or ultrafiltration unit is significantly smaller than the molecular weight of your protein to prevent its loss. For size exclusion columns, choose a resin with an appropriate fractionation range for your protein's size.
- **Improper Sample Loading:** For spin columns, applying a sample volume outside the recommended range can lead to poor recovery.

## Troubleshooting Guide

Problem	Possible Cause(s)	Recommended Solution(s)
High background in downstream assays (e.g., ELISA, Western Blot)	Incomplete removal of excess biotin.	- Increase the duration or number of buffer changes during dialysis.- Use a fresh desalting column for each purification.- For spin columns, consider a second pass to remove more free biotin.
Low signal in streptavidin-based assays	- Over-biotinylation causing protein aggregation or loss of function.- Insufficient biotinylation.	- Optimize the molar ratio of biotin to protein in your labeling reaction.- Use a traceable biotin reagent to quantify the degree of biotinylation.
Precipitation of the protein after biotinylation	Over-labeling with hydrophobic biotin can cause insolubility.	- Reduce the molar excess of the biotinylation reagent in the reaction.- Use a more water-soluble biotinylation reagent, such as one with a PEG spacer.
Inconsistent results between batches	- Variation in the biotinylation reaction efficiency.- Incomplete removal of the biotin reagent.	- Ensure the protein concentration and buffer conditions (pH 7-9, amine-free) are consistent.- Use a standardized purification protocol with consistent timing and volumes.

## Experimental Protocols & Workflows

### Method 1: Dialysis

This method is suitable for removing small molecules from large proteins and is gentle on the sample.

## Protocol:

- Hydrate the dialysis tubing or cassette membrane according to the manufacturer's instructions.
- Load the biotinylation reaction mixture into the dialysis tubing/cassette, ensuring to leave some space for potential volume increase.
- Place the sealed tubing/cassette in a beaker containing a large volume of dialysis buffer (e.g., PBS), typically 100-200 times the sample volume.
- Stir the dialysis buffer gently on a magnetic stir plate at 4°C.
- Allow dialysis to proceed for at least 4 hours, or overnight for more complete removal.
- Change the dialysis buffer at least 2-3 times to ensure efficient removal of the free biotin.
- Recover the purified biotinylated protein from the dialysis tubing/cassette.

## Workflow Diagram:

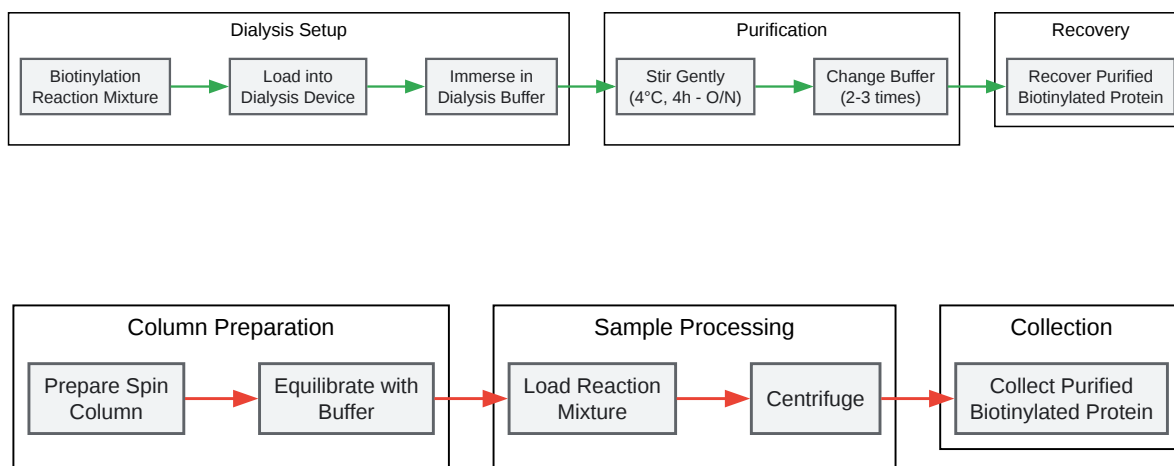

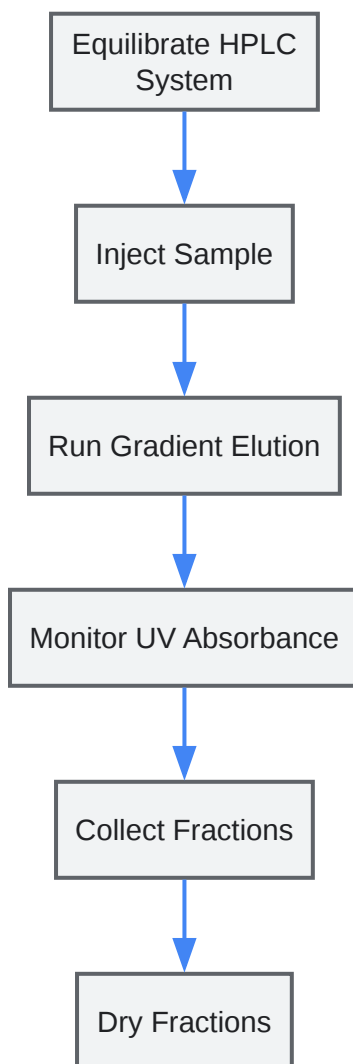

[Click to download full resolution via product page](#)

### ***Need Custom Synthesis?***

*BenchChem offers custom synthesis for rare earth carbides and specific isotopic labeling.*

*Email: [info@benchchem.com](mailto:info@benchchem.com) or [Request Quote Online](#).*

## References

- [1. Small Molecule and Biotin Removal | Thermo Fisher Scientific - TR \[thermofisher.com\]](#)
- [2. researchgate.net \[researchgate.net\]](#)

- [3. biochemistry - How do I remove free biotin after biotin-protein conjugation? - Chemistry Stack Exchange \[chemistry.stackexchange.com\]](#)
- To cite this document: BenchChem. [Technical Support Center: Post-Biotinylation Purification]. BenchChem, [2026]. [Online PDF]. Available at: [<https://www.benchchem.com/product/b606146/docs#technical-support-center-post-biotinylation-purification>]

---

### Disclaimer & Data Validity:

The information provided in this document is for Research Use Only (RUO) and is strictly not intended for diagnostic or therapeutic procedures. While BenchChem strives to provide accurate protocols, we make no warranties, express or implied, regarding the fitness of this product for every specific experimental setup.

**Technical Support:** The protocols provided are for reference purposes. Unsure if this reagent suits your experiment?

**Need Industrial/Bulk Grade?** [Request Custom Synthesis Quote](#)

## BenchChem

Our mission is to be the trusted global source of essential and advanced chemicals, empowering scientists and researchers to drive progress in science and industry.

### Contact

Address: 3281 E Guasti Rd  
Ontario, CA 91761, United States  
Phone: (601) 213-4426  
Email: [info@benchchem.com](mailto:info@benchchem.com)

[Contact our Ph.D. Support Team for a compatibility check](#)