

Independent Verification of Lana-DNA-IN-1 IC50 Value: A Comparative Guide

Author: BenchChem Technical Support Team. **Date:** April 2026

Compound of Interest

Compound Name: *Lana-DNA-IN-1*

Cat. No.: *B12404806*

[Get Quote](#)

For researchers, scientists, and drug development professionals, this guide provides an objective comparison of the inhibitory activity of **Lana-DNA-IN-1** and its alternatives. This document summarizes available experimental data to facilitate informed decisions in research and development involving the inhibition of the LANA-DNA interaction, a critical process for the latent persistence of Kaposi's Sarcoma-Associated Herpesvirus (KSHV).

The Latency-Associated Nuclear Antigen (LANA) encoded by KSHV is essential for the replication and maintenance of the viral genome during latency.[1][2] It achieves this by binding to specific DNA sequences within the terminal repeats (TRs) of the viral genome, tethering it to host chromosomes to ensure its segregation into daughter cells during mitosis.[3][4] This interaction is a prime target for therapeutic intervention against KSHV-associated malignancies. [1] **Lana-DNA-IN-1** is a known inhibitor of this interaction.

Comparative Analysis of Inhibitor Potency

The following table summarizes the half-maximal inhibitory concentration (IC50) values for **Lana-DNA-IN-1** and other reported inhibitors of the LANA-DNA interaction. It is important to note that direct independent verification of the IC50 value for **Lana-DNA-IN-1** was not found in

the public domain at the time of this publication. The values presented are as reported by the respective sources.

Compound	IC50 Value (μM)	Assay Method	Target	Source
Lana-DNA-IN-1	8	Fluorescence Polarization (FP)	LBS2	MedchemExpress[5]
9	Fluorescence Polarization (FP)	LBS1	MedchemExpress[5]	
8	Fluorescence Polarization (FP)	LBS3	MedchemExpress[5]	
53	Not Specified	Wild-type LANA	MedchemExpress[5]	
Compound 20 (Unnamed)	33.2 ± 3.6	Southern Blot	LANA-mediated replication	PMC (2023)[6]
Inhibitor I	17 ± 1	Fluorescence Polarization (FP)	LBS2	ResearchGate[7]
426 ± 2	Electrophoretic Mobility Shift Assay (EMSA)	LANA DBD mutant	ResearchGate[7]	

LBS1, LBS2, and LBS3 refer to the different LANA-binding sites within the KSHV terminal repeats. The DNA Binding Domain (DBD) of LANA is the specific region of the protein that interacts with the DNA.

Experimental Protocols

The determination of IC50 values for inhibitors of the LANA-DNA interaction typically involves a variety of biophysical and cell-based assays. Below are detailed methodologies for the key experiments cited.

Fluorescence Polarization (FP) Assay

This assay measures the change in the polarization of fluorescently labeled DNA upon binding to the LANA protein. Small, unbound fluorescently labeled DNA tumbles rapidly in solution, resulting in low polarization. When bound to the larger LANA protein, the tumbling is slower, leading to an increase in polarization. Inhibitors that disrupt this interaction will cause a decrease in polarization.

Protocol:

- Reagents and Materials:
 - Purified recombinant LANA protein (or its DNA-binding domain).
 - Fluorescently labeled DNA probe containing a LANA binding site (e.g., LBS1, LBS2, or LBS3).
 - Assay buffer (e.g., PBS with 0.01% Tween-20).
 - Test compounds (inhibitors) at various concentrations.
 - Microplate reader with fluorescence polarization capabilities.
- Procedure:
 - A fixed concentration of the fluorescently labeled DNA probe and LANA protein are incubated together in the assay buffer to allow for binding.
 - The test compound is added to the mixture at a range of concentrations.
 - The reaction is incubated to reach equilibrium.
 - The fluorescence polarization of each sample is measured using a microplate reader.
- Data Analysis:
 - The percentage of inhibition is calculated for each concentration of the test compound relative to a control with no inhibitor.

- The IC50 value is determined by plotting the percentage of inhibition against the logarithm of the inhibitor concentration and fitting the data to a dose-response curve.

Electrophoretic Mobility Shift Assay (EMSA)

EMSA is used to detect protein-DNA interactions. A radiolabeled or fluorescently labeled DNA probe containing the LANA binding site is incubated with the LANA protein. If the protein binds to the DNA, the resulting complex will migrate more slowly through a non-denaturing polyacrylamide gel than the free DNA probe.

Protocol:

- Reagents and Materials:
 - Purified recombinant LANA protein.
 - Radiolabeled or fluorescently labeled DNA probe with a LANA binding site.
 - Binding buffer (containing non-specific competitor DNA like poly(dI-dC) to reduce non-specific binding).
 - Test compounds at various concentrations.
 - Non-denaturing polyacrylamide gel.
 - Electrophoresis apparatus and buffer.
 - Detection system (autoradiography for radiolabeled probes or fluorescence imaging).
- Procedure:
 - The LANA protein is pre-incubated with the test compound at various concentrations in the binding buffer.
 - The labeled DNA probe is then added to the mixture and incubated to allow for binding.
 - The samples are loaded onto a non-denaturing polyacrylamide gel and subjected to electrophoresis.

- The gel is dried (for radiolabeled probes) and exposed to X-ray film or imaged using a fluorescence scanner.
- Data Analysis:
 - The intensity of the band corresponding to the LANA-DNA complex is quantified.
 - The percentage of inhibition is calculated for each inhibitor concentration.
 - The IC50 value is determined by plotting the percentage of inhibition against the inhibitor concentration.

Southern Blot for LANA-Mediated Replication

This cell-based assay assesses the ability of an inhibitor to block the replication of a plasmid containing the KSHV terminal repeats in cells expressing LANA.

Protocol:

- Cell Culture and Transfection:
 - Cells that do not contain KSHV (e.g., 293T) are co-transfected with a plasmid expressing LANA and a target plasmid containing the KSHV terminal repeats.
 - The transfected cells are cultured in the presence of the test compound at various concentrations.
- DNA Extraction and Digestion:
 - After a period of incubation (e.g., 72 hours), low molecular weight DNA is extracted from the cells.
 - The extracted DNA is digested with a restriction enzyme that linearizes the plasmid (e.g., EcoRI) and another enzyme that specifically cuts bacterially methylated DNA (e.g., DpnI). DpnI will digest the input, non-replicated plasmid DNA, but not the newly replicated DNA generated in the mammalian cells.
- Gel Electrophoresis and Blotting:

- The digested DNA is separated by agarose gel electrophoresis.
- The DNA is then transferred from the gel to a membrane (e.g., nitrocellulose or nylon).
- Hybridization and Detection:
 - The membrane is incubated with a labeled DNA probe specific for the KSHV terminal repeats.
 - The signal from the probe is detected, indicating the amount of replicated plasmid DNA.
- Data Analysis:
 - The intensity of the band corresponding to the replicated DNA is quantified for each inhibitor concentration.
 - The IC50 value is calculated by plotting the amount of replicated DNA against the inhibitor concentration.

Visualizing the Mechanism and Workflow

To better understand the underlying biological process and the experimental approach, the following diagrams illustrate the LANA-DNA interaction pathway and a generalized workflow for IC50 determination.

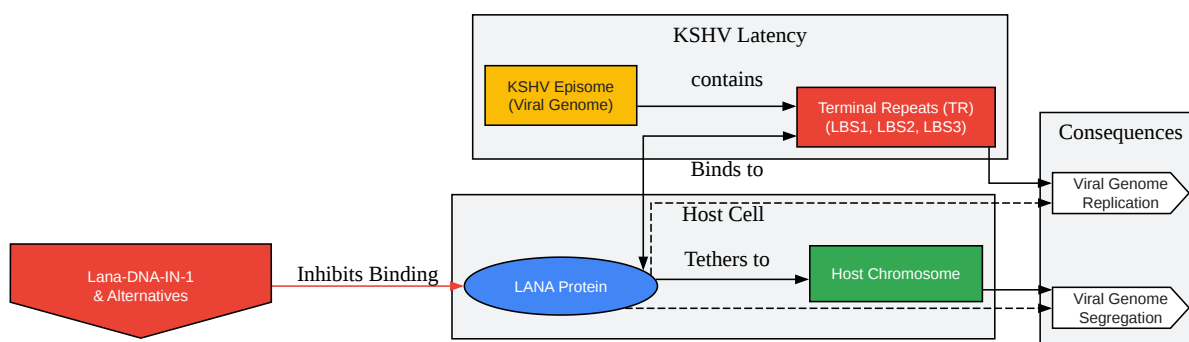

[Click to download full resolution via product page](#)

Caption: KSHV LANA protein interaction with the viral genome and host chromosome.

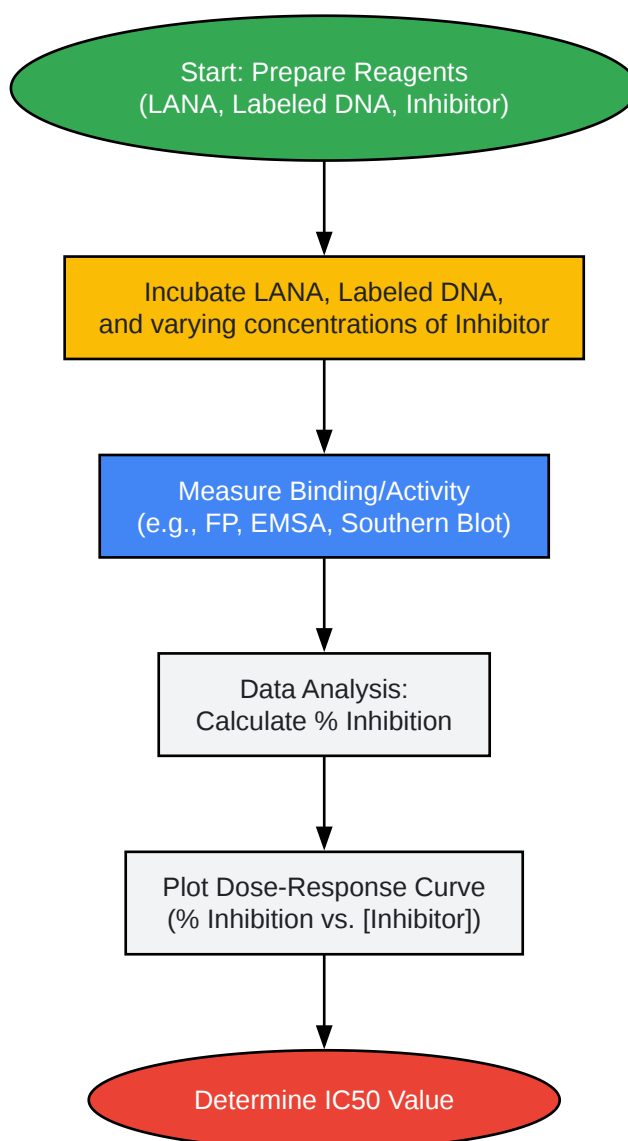

[Click to download full resolution via product page](#)

Need Custom Synthesis?

BenchChem offers custom synthesis for rare earth carbides and specific isotopic labeling.

Email: info@benchchem.com or [Request Quote Online](#).

References

- 1. Development of a Small Molecule Inhibitor for KSHV LANA - Paul Lieberman [grantome.com]
- 2. Biophysical Screens Identify Fragments That Bind to the Viral DNA-Binding Proteins EBNA1 and LANA - PubMed [pubmed.ncbi.nlm.nih.gov]
- 3. KSHV LANA—The Master Regulator of KSHV Latency - PMC [pmc.ncbi.nlm.nih.gov]
- 4. Latency-Associated Nuclear Antigen (LANA) of Kaposi's Sarcoma-Associated Herpesvirus Interacts with Origin Recognition Complexes at the LANA Binding Sequence within the Terminal Repeats - PMC [pmc.ncbi.nlm.nih.gov]
- 5. medchemexpress.com [medchemexpress.com]
- 6. Disrupting Kaposi's Sarcoma-Associated Herpesvirus (KSHV) Latent Replication with a Small Molecule Inhibitor - PMC [pmc.ncbi.nlm.nih.gov]
- 7. researchgate.net [researchgate.net]
- To cite this document: BenchChem. [Independent Verification of Lana-DNA-IN-1 IC50 Value: A Comparative Guide]. BenchChem, [2026]. [Online PDF]. Available at: [https://www.benchchem.com/product/b12404806/docs#independent-verification-of-lana-dna-in-1-ic50-value-a-comparative-guide]

Disclaimer & Data Validity:

The information provided in this document is for Research Use Only (RUO) and is strictly not intended for diagnostic or therapeutic procedures. While BenchChem strives to provide accurate protocols, we make no warranties, express or implied, regarding the fitness of this product for every specific experimental setup.

Technical Support: The protocols provided are for reference purposes. Unsure if this reagent suits your experiment?

Need Industrial/Bulk Grade? [Request Custom Synthesis Quote](#)

BenchChem

Our mission is to be the trusted global source of essential and advanced chemicals, empowering scientists and researchers to drive progress in science and industry.

Contact

Address: 3281 E Guasti Rd

Ontario, CA 91761, United States

Phone: (601) 213-4426

Email: info@benchchem.com

[Contact our Ph.D. Support Team for a compatibility check](#)