

Application Note: Mass Spectrometry Fragmentation Analysis of Lapatinib-d4

Author: BenchChem Technical Support Team. **Date:** April 2026

Compound of Interest

Compound Name: *Lapatinib-d4-1*

Cat. No.: *B12404783*

[Get Quote](#)

For Research Use Only. Not for use in diagnostic procedures.

Introduction

Lapatinib is a potent, orally active dual tyrosine kinase inhibitor that targets both the Epidermal Growth factor Receptor (EGFR, ErbB1) and Human Epidermal growth factor Receptor 2 (HER2, ErbB2).[1] By inhibiting these pathways, Lapatinib disrupts downstream signaling cascades, including the PI3K/Akt and MAPK pathways, which are crucial for cell proliferation and survival in HER2-positive breast cancer.[2][3][4] Lapatinib-d4 is a deuterated internal standard of Lapatinib, essential for accurate quantification in biological matrices by mass spectrometry. Understanding its fragmentation pattern is critical for developing robust bioanalytical methods. This application note provides a detailed mass spectrometry fragmentation pattern of Lapatinib-d4, a protocol for its analysis, and a visualization of its mechanism of action.

Experimental Protocol

This protocol outlines a general procedure for the fragmentation analysis of Lapatinib-d4 using a liquid chromatography-tandem mass spectrometry (LC-MS/MS) system.

1. Sample Preparation:

- Prepare a stock solution of Lapatinib-d4 at a concentration of 1 mg/mL in a suitable organic solvent such as methanol or DMSO.
- Dilute the stock solution with an appropriate solvent mixture (e.g., 50:50 acetonitrile:water with 0.1% formic acid) to a final concentration of 1 µg/mL for direct infusion or LC-MS/MS analysis.

2. Liquid Chromatography (for LC-MS/MS analysis):

- LC System: A high-performance liquid chromatography (HPLC) or ultra-high-performance liquid chromatography (UHPLC) system.
- Column: A reversed-phase C18 column (e.g., 2.1 x 50 mm, 1.8 µm) is suitable for separating Lapatinib-d4 from potential contaminants.
- Mobile Phase A: Water with 0.1% formic acid.
- Mobile Phase B: Acetonitrile with 0.1% formic acid.
- Gradient: A typical gradient would start with a low percentage of mobile phase B, ramping up to a high percentage to elute the analyte.
- Flow Rate: 0.2-0.5 mL/min.
- Injection Volume: 5-10 µL.

3. Mass Spectrometry:

- Mass Spectrometer: A tandem mass spectrometer (e.g., triple quadrupole or high-resolution mass spectrometer like an Orbitrap or Q-TOF) capable of MS/MS fragmentation.
- Ionization Source: Electrospray ionization (ESI) in positive ion mode.
- Ion Source Parameters:
 - Capillary Voltage: 3.5 - 4.5 kV

- Source Temperature: 120 - 150 °C
- Desolvation Temperature: 350 - 450 °C
- MS Method:
 - Full Scan (MS1): Acquire a full scan spectrum to identify the protonated molecular ion ($[M+H]^+$) of Lapatinib-d4 (expected $m/z \approx 585.1$).
 - Product Ion Scan (MS/MS): Select the $[M+H]^+$ ion of Lapatinib-d4 as the precursor ion and fragment it using collision-induced dissociation (CID). A range of collision energies (e.g., 20-50 eV) should be applied to obtain a comprehensive fragmentation pattern.

Data Presentation

The mass spectrometry analysis of Lapatinib-d4 reveals a characteristic fragmentation pattern. The protonated molecular ion ($[M+H]^+$) is observed at an m/z of 585.1. The major product ions are summarized in the table below. The fragmentation is consistent with that of unlabeled Lapatinib, with a +4 Da mass shift in fragments containing the deuterated portion of the molecule.

| Precursor Ion (m/z) | Product Ion (m/z) | Proposed Fragment Structure/Neutral Loss |
|---------------------|-------------------|--|
| 585.1 | 365.0 | $[C_{20}H_{18}ClFN_3O_2S+H]^+$ |
| 585.1 | 350.0 | $[C_{19}H_{15}ClFN_2O_2S]^+$ |
| 585.1 | 332.0 | $[C_{19}H_{13}ClFN_2O]^+$ |
| 585.1 | 308.0 | $[C_{16}H_{11}ClFN_2O]^+$ |

Note: The proposed fragment structures are based on the known fragmentation of Lapatinib and the expected location of the deuterium labels.

Visualizations

Experimental Workflow

The following diagram illustrates the general workflow for the mass spectrometry fragmentation analysis of Lapatinib-d4.

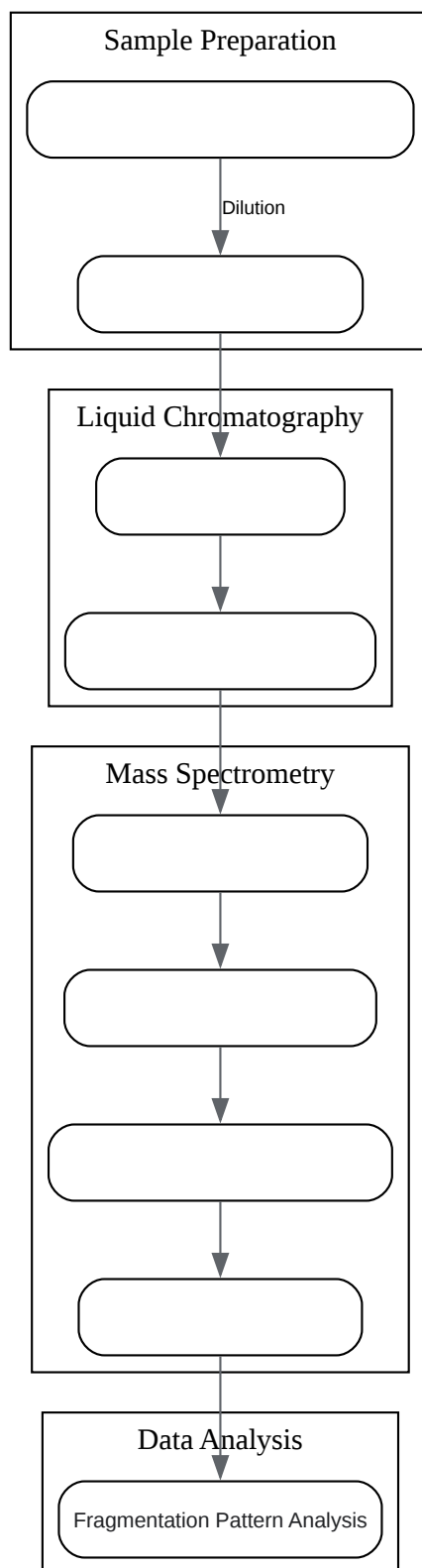

[Click to download full resolution via product page](#)

Caption: Experimental workflow for Lapatinib-d4 fragmentation analysis.

Signaling Pathway

Lapatinib inhibits the tyrosine kinase activity of EGFR (HER1) and HER2, thereby blocking downstream signaling pathways that promote cell proliferation and survival.

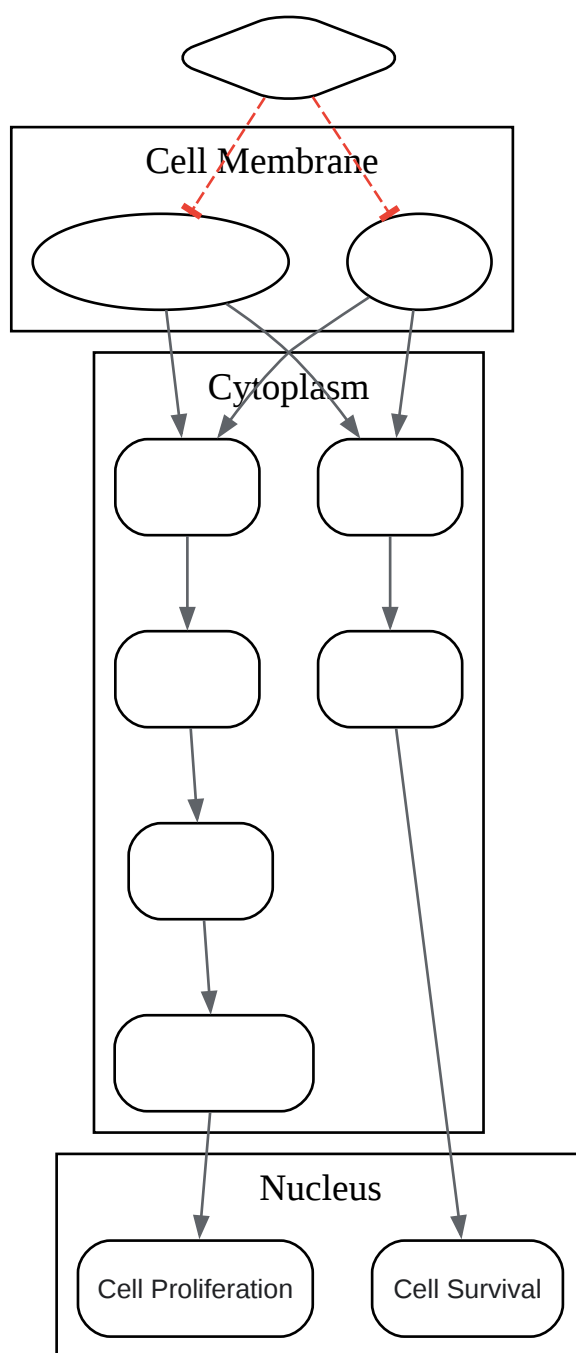

[Click to download full resolution via product page](#)

Need Custom Synthesis?

BenchChem offers custom synthesis for rare earth carbides and specific isotopic labeling.

Email: info@benchchem.com or [Request Quote Online](#).

References

- [1. go.drugbank.com](https://go.drugbank.com) [go.drugbank.com]
- [2. researchgate.net](https://researchgate.net) [researchgate.net]
- [3. Efficacy and mechanism of action of the tyrosine kinase inhibitors gefitinib, lapatinib and neratinib in the treatment of HER2-positive breast cancer: preclinical and clinical evidence - PMC](#) [[pmc.ncbi.nlm.nih.gov](https://pubmed.ncbi.nlm.nih.gov/)]
- [4. researchgate.net](https://researchgate.net) [researchgate.net]
- To cite this document: BenchChem. [Application Note: Mass Spectrometry Fragmentation Analysis of Lapatinib-d4]. BenchChem, [2026]. [Online PDF]. Available at: [<https://www.benchchem.com/product/b12404783/docs#application-note-mass-spectrometry-fragmentation-analysis-of-lapatinib-d4>]

Disclaimer & Data Validity:

The information provided in this document is for Research Use Only (RUO) and is strictly not intended for diagnostic or therapeutic procedures. While BenchChem strives to provide accurate protocols, we make no warranties, express or implied, regarding the fitness of this product for every specific experimental setup.

Technical Support: The protocols provided are for reference purposes. Unsure if this reagent suits your experiment?

Need Industrial/Bulk Grade? [Request Custom Synthesis Quote](#)

BenchChem

Our mission is to be the trusted global source of essential and advanced chemicals, empowering scientists and researchers to drive progress in science and industry.

Contact

Address: 3281 E Guasti Rd

Ontario, CA 91761, United States

Phone: (601) 213-4426

Email: info@benchchem.com

[Contact our Ph.D. Support Team for a compatibility check](#)