

An In-depth Technical Guide to Lapatinib-d4: Chemical Properties, Structure, and Mechanism

Author: BenchChem Technical Support Team. **Date:** April 2026

Compound of Interest

Compound Name: *Lapatinib-d4-1*

Cat. No.: *B12404783*

[Get Quote](#)

This technical guide provides a comprehensive overview of Lapatinib-d4, a deuterated analog of Lapatinib. It is intended for researchers, scientists, and drug development professionals, offering detailed information on its chemical properties, structure, mechanism of action, and relevant experimental protocols.

Core Chemical and Physical Properties

Lapatinib-d4 is a stable, isotope-labeled version of Lapatinib, a potent dual tyrosine kinase inhibitor. The deuterium labeling makes it a valuable internal standard for quantitative bioanalytical studies, such as mass spectrometry and liquid chromatography, ensuring precise and accurate measurements of Lapatinib in biological samples.^{[1][2]}

Property	Value	Source
IUPAC Name	N-{3-chloro-4-[(3-fluorophenyl)methoxy]phenyl}-6-[5-([2-methanesulfonyl(1,1,2,2- ² H ₄)ethyl]amino)methyl)furan-2-yl]quinazolin-4-amine	[3]
CAS Number	1184263-99-7	[3]
Molecular Formula	C ₂₉ H ₂₂ D ₄ ClFN ₄ O ₄ S	[4]
Molecular Weight	585.09 g/mol	[3]
Appearance	Yellow solid	[5][6]
Solubility	Water: 0.007 mg/mL (for Lapatinib)	[5][6]
Storage Temperature	2-8 °C	[3]
Purity	≥99%	[3]

Chemical Structure

Lapatinib is a 4-anilinoquinazoline derivative.[6][7] The structure of Lapatinib-d4 is identical to that of Lapatinib, with the exception of four deuterium atoms replacing four hydrogen atoms on the ethyl group of the methylsulfonyl ethylamino methyl side chain.

Structure of Lapatinib: N-[3-Chloro-4-[(3-fluorophenyl)methoxy]phenyl]-6-[5-[(2-methylsulfonyl)ethylamino)methyl]-2-furyl]quinazolin-4-amine[5][8]

The deuteration in Lapatinib-d4 is specifically at the 1,1,2,2 positions of the ethyl group attached to the sulfonyl group.

Mechanism of Action and Signaling Pathways

Lapatinib is a dual tyrosine kinase inhibitor that targets the intracellular kinase domains of both the Epidermal Growth Factor Receptor (EGFR, also known as ErbB1) and the Human

Epidermal Growth Factor Receptor 2 (HER2, also known as ErbB2).[8][9][10][11][12] By binding to the ATP-binding pocket of these receptors, Lapatinib prevents their autophosphorylation and subsequent activation of downstream signaling pathways.[8][13] This inhibition blocks critical pathways for cell proliferation and survival, including the Ras/Raf/MEK/ERK (MAPK) and the PI3K/Akt/mTOR pathways, ultimately leading to cell cycle arrest and apoptosis in cancer cells that overexpress these receptors.[9][11][13][14]

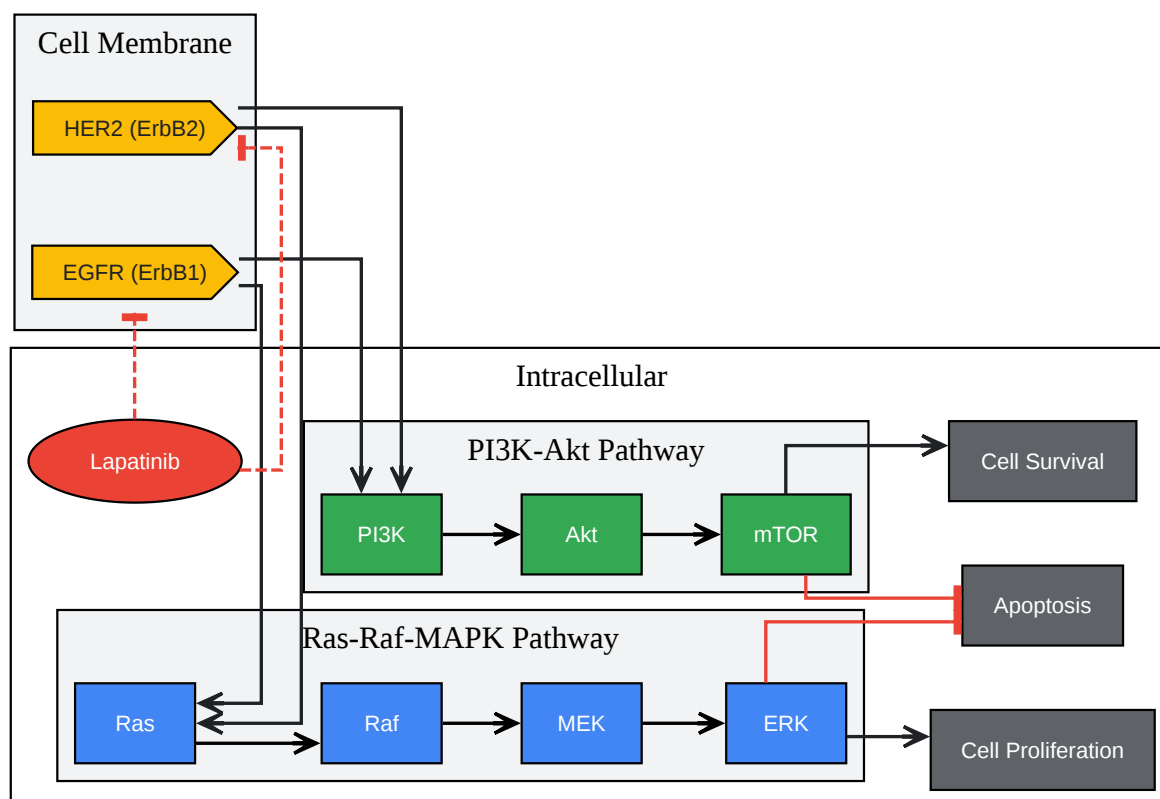

[Click to download full resolution via product page](#)

Lapatinib inhibits EGFR and HER2 signaling pathways.

Synthesis and Formulation

While specific synthesis details for Lapatinib-d4 are proprietary, the general synthesis of Lapatinib has been reported. One environmentally responsible synthesis involves a 5-step, 3-pot sequence primarily using recyclable water as a solvent, which is a greener alternative to

methods relying on organic solvents.[15] Another patented method describes a one-pot reaction with a high conversion rate and purity, suitable for industrial production.[16] The synthesis of Lapatinib-d4 would involve a similar pathway, with the introduction of a deuterated starting material or reagent at the appropriate step to achieve the desired labeling.

The final drug product is typically formulated as a ditosylate salt monohydrate.[6] Each 250 mg tablet of the brand name drug TYKERB® contains 405 mg of lapatinib ditosylate monohydrate, which is equivalent to 250 mg of the lapatinib free base.[6]



[Click to download full resolution via product page](#)

A simplified workflow for the synthesis of Lapatinib.

Experimental Protocols

Lapatinib and its deuterated form are often analyzed using reversed-phase high-performance liquid chromatography (RP-HPLC), frequently coupled with mass spectrometry (LC-MS) for bioanalytical applications.[17][18]

Example RP-HPLC Method for Lapatinib Estimation:[18]

- Instrumentation: High-Performance Liquid Chromatography system with UV detection.
- Column: ODS C-18 RP column (4.6 mm i.d. × 250 mm).
- Mobile Phase: A mixture of acetonitrile and water (50:50 v/v).
- Flow Rate: 1.0 mL/min.
- Detection Wavelength: 232 nm.
- Internal Standard: Gemcitabine Hydrochloride.
- Retention Times: Lapatinib (4.25 ± 0.05 min), Gemcitabine Hydrochloride (6.10 ± 0.05 min).

- Linearity: 2-60 µg/mL.
- Limit of Detection (LOD): 0.265 µg/mL.
- Limit of Quantitation (LOQ): 0.884 µg/mL.

Bioanalytical Method using LC-MS:[\[17\]](#)

For the determination of Lapatinib in human plasma, a liquid-liquid extraction is typically performed, followed by LC-MS analysis. Lapatinib-d4 serves as the internal standard in such assays.

- Sample Preparation: Liquid-liquid extraction with a solvent like methyl t-butyl ether.
- Chromatographic Separation: A C18 column (e.g., Zorbax SB-C18) with an isocratic mobile phase.
- Mobile Phase: A mixture of a formic buffer and an organic phase (acetonitrile/methanol/formic acid).
- Detection: Single quadrupole or tandem mass spectrometry.

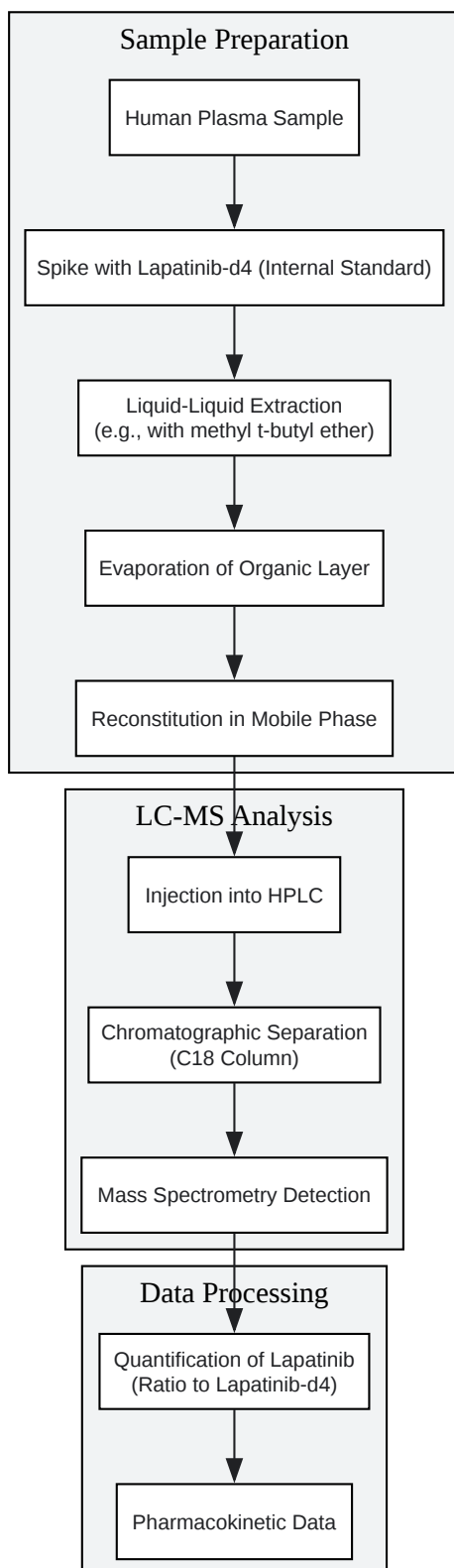

[Click to download full resolution via product page](#)

A typical workflow for the bioanalysis of Lapatinib.

Need Custom Synthesis?

BenchChem offers custom synthesis for rare earth carbides and specific isotopic labeling.

Email: info@benchchem.com or [Request Quote Online](#).

References

- [1. veeprho.com \[veeprho.com\]](#)
- [2. veeprho.com \[veeprho.com\]](#)
- [3. sigmaaldrich.com \[sigmaaldrich.com\]](#)
- [4. pharmaffiliates.com \[pharmaffiliates.com\]](#)
- [5. Lapatinib | C29H26CIFN4O4S | CID 208908 - PubChem \[pubchem.ncbi.nlm.nih.gov\]](#)
- [6. novartis.com \[novartis.com\]](#)
- [7. ijpsjournal.com \[ijpsjournal.com\]](#)
- [8. Lapatinib - Wikipedia \[en.wikipedia.org\]](#)
- [9. researchgate.net \[researchgate.net\]](#)
- [10. The research on lapatinib in autophagy, cell cycle arrest and epithelial to mesenchymal transition via Wnt/ErK/PI3K-AKT signaling pathway in human cutaneous squamous cell carcinoma - PMC \[pmc.ncbi.nlm.nih.gov\]](#)
- [11. What is the mechanism of Lapatinib Ditosylate Hydrate? \[synapse.patsnap.com\]](#)
- [12. go.drugbank.com \[go.drugbank.com\]](#)
- [13. Lapatinib for Advanced or Metastatic Breast Cancer - PMC \[pmc.ncbi.nlm.nih.gov\]](#)
- [14. Mechanism of Lapatinib-Mediated Radiosensitization of Breast Cancer Cells is Primarily by Inhibition of the Raf>MEK>ERK Mitogen-Activated Protein Kinase Cascade and Radiosensitization of Lapatinib-Resistant Cells Restored by Direct Inhibition of MEK - PMC \[pmc.ncbi.nlm.nih.gov\]](#)
- [15. An environmentally responsible synthesis of the antitumor agent lapatinib \(Tykerb\) - Green Chemistry \(RSC Publishing\) \[pubs.rsc.org\]](#)
- [16. CN103159747A - Synthetic method of lapatinib - Google Patents \[patents.google.com\]](#)
- [17. ptfarm.pl \[ptfarm.pl\]](#)

- [18. A Validated RP-HPLC Method for the Estimation of Lapatinib in Tablet Dosage form using Gemcitabine Hydrochloride as an Internal Standard - PMC \[pmc.ncbi.nlm.nih.gov\]](#)
- To cite this document: BenchChem. [An In-depth Technical Guide to Lapatinib-d4: Chemical Properties, Structure, and Mechanism]. BenchChem, [2026]. [Online PDF]. Available at: [<https://www.benchchem.com/product/b12404783/docs#an-in-depth-technical-guide-to-lapatinib-d4-chemical-properties-structure-and-mechanism>]

Disclaimer & Data Validity:

The information provided in this document is for Research Use Only (RUO) and is strictly not intended for diagnostic or therapeutic procedures. While BenchChem strives to provide accurate protocols, we make no warranties, express or implied, regarding the fitness of this product for every specific experimental setup.

Technical Support: The protocols provided are for reference purposes. Unsure if this reagent suits your experiment?

Need Industrial/Bulk Grade? [Request Custom Synthesis Quote](#)

BenchChem

Our mission is to be the trusted global source of essential and advanced chemicals, empowering scientists and researchers to drive progress in science and industry.

Contact

Address: 3281 E Guasti Rd
Ontario, CA 91761, United States
Phone: (601) 213-4426
Email: info@benchchem.com

[Contact our Ph.D. Support Team for a compatibility check](#)