

Troubleshooting variability in temsavir IC50 values

Author: BenchChem Technical Support Team. **Date:** April 2026

Compound of Interest

Compound Name: *HIV-1 inhibitor-31*

CAS No.: *920036-04-0*

Cat. No.: *B12403047*

[Get Quote](#)

Technical Support Center: Temsavir IC50 Assays

This technical support center provides troubleshooting guidance and frequently asked questions (FAQs) for researchers, scientists, and drug development professionals who are determining the IC50 value of temsavir, a potent HIV-1 attachment inhibitor.

Frequently Asked Questions (FAQs)

Q1: What is temsavir and how does it work?

Temsavir is the active form of the prodrug fostemsavir. It is a first-in-class HIV-1 attachment inhibitor.^{[1][2]} Temsavir directly binds to the gp120 subunit of the HIV-1 envelope glycoprotein, preventing the initial interaction between the virus and the host cell's CD4 receptor.^{[3][4][5][6]} This action blocks the first step of the viral lifecycle, inhibiting viral entry into the host cell.^{[1][3]}

Q2: What is a typical IC50 value for temsavir?

The IC50 (half-maximal inhibitory concentration) of temsavir against HIV-1 can vary significantly depending on the viral subtype and the presence of specific mutations. Generally,

temsavir exhibits potent activity with IC50 values ranging from subnanomolar to the low nanomolar range against wild-type HIV-1.[7][8] For example, IC50 values of 2.26 nM, 0.34 nM, and 1.3 nM have been reported for HIV-1 subtypes A, B, and C, respectively.[8]

Q3: My temsavir IC50 values are highly variable between experiments. What are the potential causes?

Variability in IC50 values can arise from several factors, broadly categorized as biological and technical.

- Biological Factors:
 - HIV-1 Strain and Subtype: Different HIV-1 subtypes and strains can exhibit varying susceptibility to temsavir.
 - gp120 Mutations: The primary cause of significant variability and resistance is the presence of mutations in the gp120 protein, the target of temsavir. Specific amino acid substitutions at positions S375, M426, M434, and M475 are known to reduce susceptibility.[2][3][7]
 - Cell Line Choice: The type of host cell line used in the assay can influence the IC50 value. [9] Different cell lines may express varying levels of CD4 and co-receptors (CCR5 or CXCR4), affecting viral entry kinetics.
- Technical Factors:
 - Assay Method: Different assay formats (e.g., pseudovirus neutralization vs. plaque reduction) can yield different IC50 values.
 - Reagent Quality and Consistency: Variations in the quality and concentration of reagents such as cell culture media, serum, and the temsavir compound itself can lead to inconsistent results.
 - Experimental Technique: Inconsistent cell seeding density, pipetting errors, and variations in incubation times can all contribute to variability.

- Data Analysis: The method used to calculate the IC50 from the dose-response curve can impact the final value.

Q4: Which mutations in gp120 are known to cause resistance to temsavir?

Mutations at several key positions within the gp120 protein have been associated with reduced susceptibility to temsavir. The most well-characterized resistance-associated mutations occur at amino acid positions:

- S375 (H/I/M/N/T/Y)[\[2\]](#)[\[7\]](#)
- M426 (L/P)[\[2\]](#)[\[7\]](#)
- M434 (I/K)[\[2\]](#)[\[7\]](#)
- M475 (I)[\[2\]](#)[\[7\]](#)
- T202 (E)[\[7\]](#)

The presence of these mutations, either alone or in combination, can lead to a significant increase in the IC50 value of temsavir.

Data Presentation: Temsavir IC50 Fold-Change with gp120 Mutations

The following table summarizes the reported fold-changes in temsavir IC50 values resulting from specific mutations in the HIV-1 gp120 protein. The fold-change is calculated relative to the wild-type virus.

Mutation	Fold-Change in IC50	Reference(s)
S375H	4-fold to >12,500-fold	[8]
S375I	4-fold to >12,500-fold	[8]
S375M	4-fold to >12,500-fold	[8]
S375N	4-fold to >12,500-fold	[2][8]
M426L	4-fold to >12,500-fold	[2][8]
M434I	4-fold to >12,500-fold	[8]
M475I	4-fold to >12,500-fold	[8]
S375H + M475I	>29,700-fold	[8]

Note: The wide range in fold-change can be attributed to the specific viral backbone and the assay system used. A fold-change of >3 is generally considered a significant increase in resistance.[3]

Experimental Protocols

Detailed Methodology: HIV-1 Pseudovirus-Based Neutralization Assay

This is a common method for determining the IC50 of antiviral compounds like temsavir. The assay measures the inhibition of viral entry into a reporter cell line.

Materials:

- Cell Lines:
 - HEK293T cells (for pseudovirus production)
 - TZM-bl or A3R5 cells (reporter cell line expressing CD4, CCR5, and CXCR4, and containing a Tat-inducible luciferase reporter gene)
- Plasmids:

- An HIV-1 env-expressing plasmid (encoding the gp160 of the desired HIV-1 strain)
- An env-deficient HIV-1 backbone plasmid (e.g., pSG3ΔEnv)
- Reagents:
 - Temsavir (dissolved in DMSO)
 - Cell culture medium (e.g., DMEM) supplemented with fetal bovine serum (FBS) and antibiotics
 - Transfection reagent (e.g., FuGENE 6)
 - Luciferase assay reagent (e.g., Bright-Glo™)
 - 96-well cell culture plates (white, solid-bottom for luminescence reading)

Procedure:

- Pseudovirus Production:
 - Co-transfect HEK293T cells with the env-expressing plasmid and the env-deficient backbone plasmid using a suitable transfection reagent.
 - Incubate the cells for 48-72 hours.
 - Harvest the cell culture supernatant containing the pseudoviruses.
 - Clarify the supernatant by centrifugation and filter through a 0.45 µm filter.
 - Determine the virus titer (e.g., by measuring the 50% tissue culture infectious dose, TCID₅₀).
- Neutralization Assay:
 - Prepare serial dilutions of temsavir in cell culture medium in a 96-well plate.
 - Add a standardized amount of pseudovirus to each well containing the temsavir dilutions.

- Incubate the plate for 1 hour at 37°C to allow the drug to bind to the virus.
- Add TZM-bl or A3R5 cells to each well.
- Incubate the plate for 48 hours at 37°C.
- Data Acquisition and Analysis:
 - After incubation, lyse the cells and add the luciferase assay reagent.
 - Measure the luminescence in each well using a luminometer.
 - Calculate the percentage of neutralization for each temsavir concentration relative to the virus control (no drug).
 - Plot the percentage of neutralization against the temsavir concentration and fit a dose-response curve to determine the IC₅₀ value (the concentration at which 50% of viral entry is inhibited).

Visualizations

HIV-1 Entry Signaling Pathway and Temsavir's Mechanism of Action

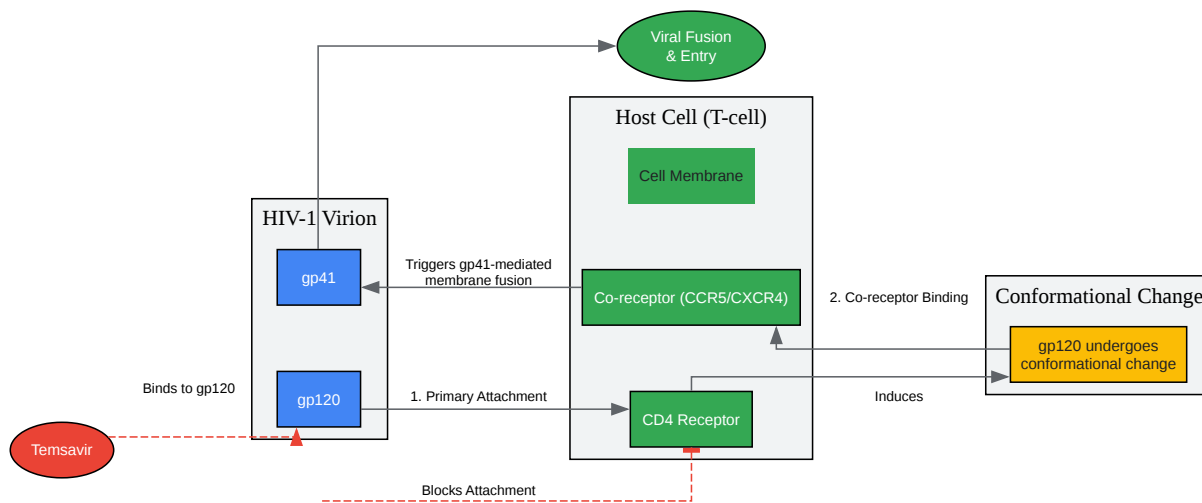

[Click to download full resolution via product page](#)

Caption: HIV-1 entry pathway and the inhibitory action of temsavir.

Experimental Workflow for Temsavir IC50 Determination

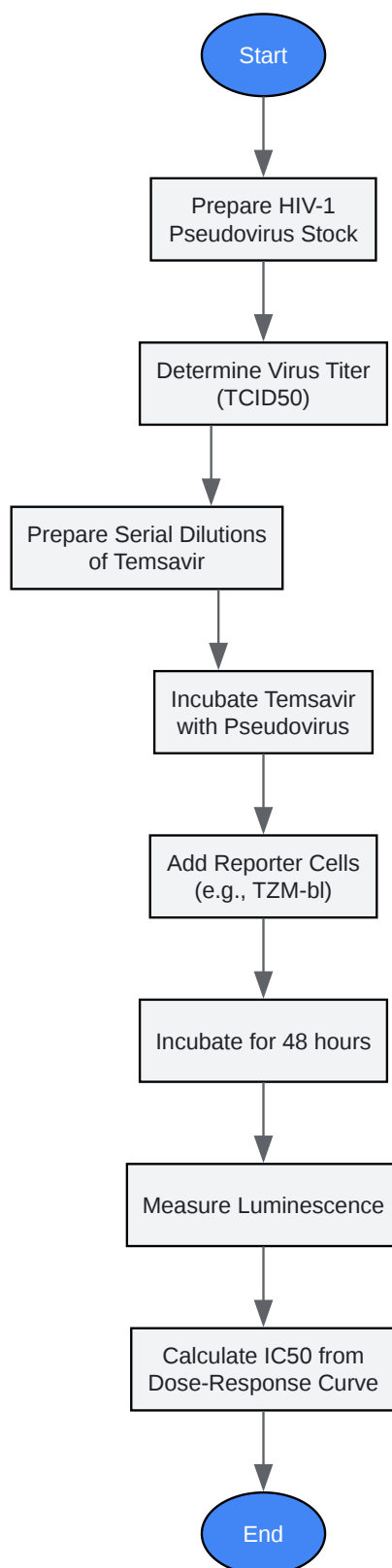

[Click to download full resolution via product page](#)

Caption: A generalized workflow for determining temsavir IC50 using a pseudovirus assay.

Troubleshooting Logic for IC50 Variability

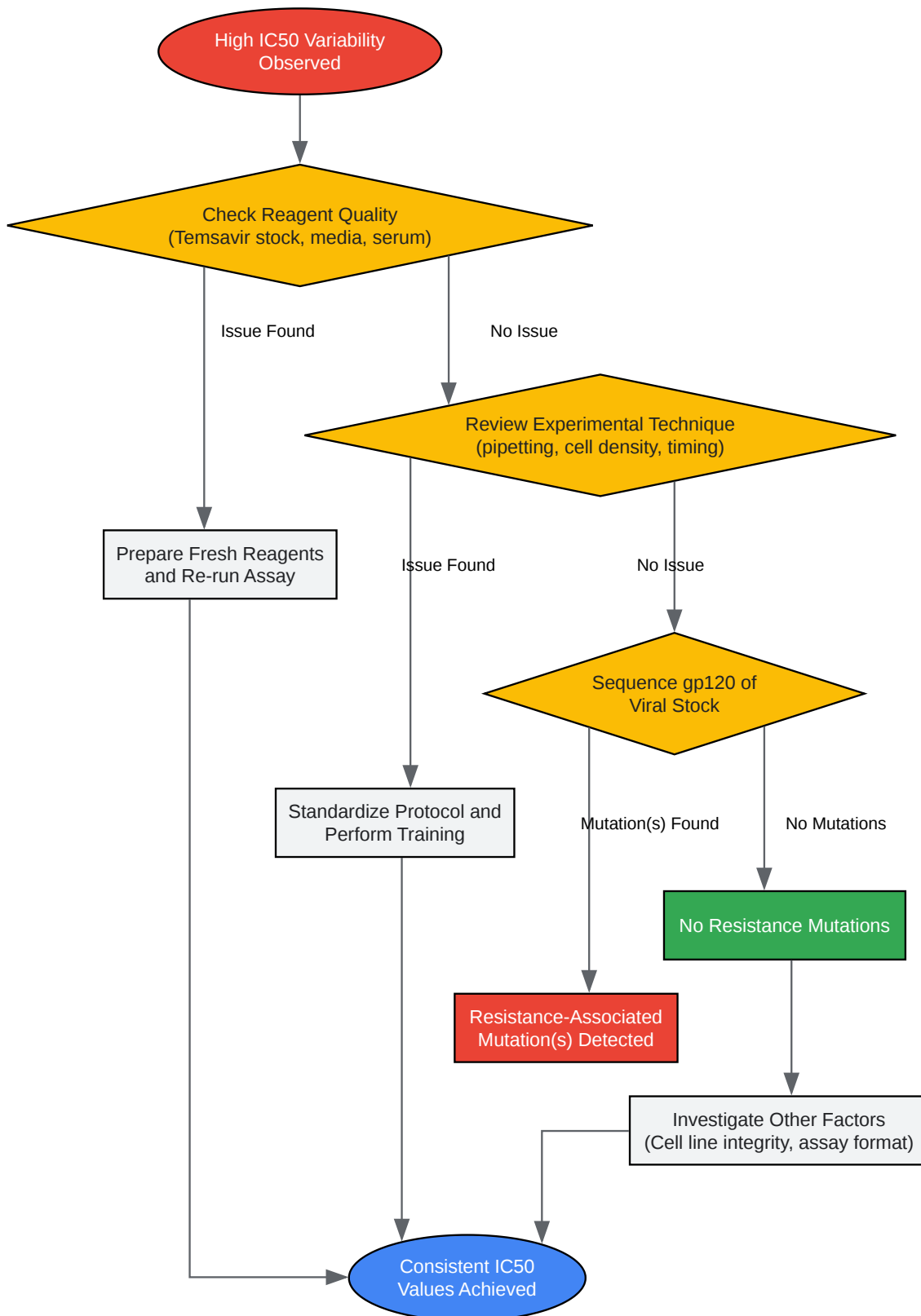

[Click to download full resolution via product page](#)

Caption: A logical workflow for troubleshooting variability in temsavir IC50 values.

Need Custom Synthesis?

BenchChem offers custom synthesis for rare earth carbides and specific isotopic labeling.

Email: info@benchchem.com or [Request Quote Online](#).

References

- 1. Tetrazolium-based plaque assay for HIV-1 and HIV-2, and its use in the evaluation of antiviral compounds - PubMed [pubmed.ncbi.nlm.nih.gov]
- 2. Mechanism of action, resistance, interaction, pharmacokinetics, pharmacodynamics, and safety of fostemsavir - PMC [[pmc.ncbi.nlm.nih.gov](https://pubmed.ncbi.nlm.nih.gov)]
- 3. Viral Drug Resistance Through 48 Weeks, in a Phase 2b, Randomized, Controlled Trial of the HIV-1 Attachment Inhibitor Prodrug, Fostemsavir - PMC [[pmc.ncbi.nlm.nih.gov](https://pubmed.ncbi.nlm.nih.gov)]
- 4. hivandmore.de [hivandmore.de]
- 5. [researchgate.net](https://www.researchgate.net) [[researchgate.net](https://www.researchgate.net)]
- 6. [ovid.com](https://www.ovid.com) [[ovid.com](https://www.ovid.com)]
- 7. Fostemsavir resistance in clinical context: a narrative review - PMC [[pmc.ncbi.nlm.nih.gov](https://pubmed.ncbi.nlm.nih.gov)]
- 8. [news-medical.net](https://www.news-medical.net) [[news-medical.net](https://www.news-medical.net)]
- 9. [osti.gov](https://www.osti.gov) [[osti.gov](https://www.osti.gov)]
- To cite this document: BenchChem. [Troubleshooting variability in temsavir IC50 values]. BenchChem, [2026]. [Online PDF]. Available at: [<https://www.benchchem.com/product/b12403047/docs#troubleshooting-variability-in-temsavir-ic50-values>]

Disclaimer & Data Validity:

The information provided in this document is for Research Use Only (RUO) and is strictly not intended for diagnostic or therapeutic procedures. While BenchChem strives to provide accurate protocols, we make no warranties, express or implied, regarding the fitness of this product for every specific experimental setup.

Technical Support: The protocols provided are for reference purposes. Unsure if this reagent suits your experiment?

Need Industrial/Bulk Grade? [Request Custom Synthesis Quote](#)

BenchChem

Our mission is to be the trusted global source of essential and advanced chemicals, empowering scientists and researchers to drive progress in science and industry.

Contact

Address: 3281 E Guasti Rd
Ontario, CA 91761, United States
Phone: (601) 213-4426
Email: info@benchchem.com

[Contact our Ph.D. Support Team for a compatibility check](#)