

Technical Support Center: Optimizing CDK7-IN-20 Concentration for Efficacy

Author: BenchChem Technical Support Team. **Date:** April 2026

Compound of Interest

Compound Name: CDK7-IN-20

Cat. No.: B12403626

[Get Quote](#)

This technical support center provides researchers, scientists, and drug development professionals with comprehensive guidance for utilizing **CDK7-IN-20** in their experiments. Below you will find frequently asked questions (FAQs) and troubleshooting guides to ensure optimal experimental outcomes.

Frequently Asked Questions (FAQs)

Q1: What is **CDK7-IN-20** and how does it work?

A1: **CDK7-IN-20** is a potent and selective inhibitor of Cyclin-Dependent Kinase 7 (CDK7). CDK7 is a crucial enzyme that plays a dual role in regulating both the cell cycle and gene transcription.^{[1][2]} As a component of the CDK-activating kinase (CAK) complex, CDK7 phosphorylates and activates other CDKs, such as CDK1, CDK2, CDK4, and CDK6, which are essential for cell cycle progression. Additionally, CDK7 is a component of the general transcription factor TFIIF, where it phosphorylates the C-terminal domain (CTD) of RNA polymerase II (Pol II), a critical step for the initiation of transcription. By inhibiting CDK7, **CDK7-IN-20** can lead to cell cycle arrest and a shutdown of key transcriptional programs that drive cell proliferation, making it a valuable tool for cancer research.

Q2: What is a recommended starting concentration for **CDK7-IN-20** in my cell line?

A2: A good starting point for **CDK7-IN-20** is to perform a dose-response experiment based on its reported half-maximal inhibitory concentration (IC50) values in various cancer cell lines. The IC50 values for the closely related compound Cdk7-IN-8, which can be used as a reference, are in the nanomolar range. For example, after 72 hours of treatment, the IC50 values are 50.85 nM for HCC70, 45.31 nM for OVCAR-3, 25.26 nM for HCT116, and 44.47 nM for HCC1806.[1][2] It is highly recommended to determine the IC50 empirically in your specific cell line. A typical starting range for a dose-response curve could be from 0.1 nM to 10 μM.[3]

Q3: How long should I treat my cells with **CDK7-IN-20**?

A3: The optimal treatment duration depends on your cell line and the biological question being investigated. For cell viability and proliferation assays, treatment times of 24 to 72 hours are common. For mechanistic studies examining more immediate effects on transcription (e.g., RNA Pol II phosphorylation) or cell cycle markers, shorter time points (e.g., 6, 12, or 24 hours) may be more appropriate.

Q4: What are the expected phenotypic effects of **CDK7-IN-20** treatment?

A4: Inhibition of CDK7 with compounds like **CDK7-IN-20** can lead to several observable phenotypes, including:

- Cell Cycle Arrest: Predominantly at the G1/S or G2/M phase.
- Induction of Apoptosis: Particularly in sensitive cancer cell lines.
- Decreased Cell Proliferation: A general reduction in the rate of cell growth.
- Inhibition of Transcription: Evidenced by reduced phosphorylation of the RNA Polymerase II C-terminal domain (CTD) at Serine 5 and Serine 7.

Q5: How should I prepare and store **CDK7-IN-20**?

A5: For long-term storage, **CDK7-IN-20** powder should be stored at -20°C. For experimental use, it is typically dissolved in dimethyl sulfoxide (DMSO) to create a high-concentration stock solution. To maintain stability, it is advisable to:

- Store the DMSO stock solution in small aliquots at -80°C to avoid repeated freeze-thaw cycles.
- Ensure the final DMSO concentration in your cell culture medium is low (typically $\leq 0.1\%$) to avoid solvent-induced cytotoxicity.

Quantitative Data Summary

The following tables summarize the reported IC50 values for CDK7 inhibitors in various cancer cell lines. This data can serve as a reference for designing your initial dose-response experiments.

Table 1: IC50 Values of Cdk7-IN-8 in Various Cancer Cell Lines

Cell Line	Cancer Type	IC50 (nM)	Treatment Duration
HCT116	Colon Carcinoma	25.26	72 hours
OVCAR-3	Ovarian Cancer	45.31	72 hours
HCC1806	Breast Cancer	44.47	72 hours
HCC70	Breast Cancer	50.85	72 hours

Data for Cdk7-IN-8 is presented as a close analog to **CDK7-IN-20**.

Table 2: IC50 Values of THZ1 (another CDK7 inhibitor) in Breast Cancer Cell Lines

Cell Line	Subtype	IC50 (nM) - 2 days	IC50 (nM) - 7 days
MCF7	ER+	130	80
T47D	ER+	150	90
MDA-MB-231	TNBC	200	120
BT-474	HER2+	180	100

This data illustrates the range of sensitivities across different breast cancer subtypes to CDK7 inhibition.

Experimental Protocols

Here are detailed methodologies for key experiments to assess the efficacy of **CDK7-IN-20**.

Protocol 1: Cell Viability and Dose-Response Curve Generation (CCK-8 Assay)

This protocol outlines the steps for determining the half-maximal inhibitory concentration (IC₅₀) of **CDK7-IN-20**.

Materials:

- Cancer cell line of interest
- Complete cell culture medium
- **CDK7-IN-20** dissolved in DMSO
- 96-well cell culture plates
- Cell Counting Kit-8 (CCK-8) reagent
- Microplate reader (450 nm absorbance)
- Phosphate-buffered saline (PBS)
- CO₂ incubator (37°C, 5% CO₂)

Procedure:

- **Cell Seeding:** Harvest and count cells. Seed cells in a 96-well plate at an optimized density (e.g., 5,000-10,000 cells/well) in 100 µL of complete culture medium. Incubate for 24 hours to allow for cell attachment.
- **Compound Treatment:** Prepare a serial dilution of **CDK7-IN-20** in complete culture medium. It is recommended to start with a wide concentration range (e.g., 0.1 nM to 10 µM). Remove the existing medium and add 100 µL of the medium containing different concentrations of the

inhibitor. Include a vehicle control (DMSO) and an untreated control. Incubate for the desired duration (e.g., 24, 48, or 72 hours).

- **Cell Viability Measurement:** Add 10 μ L of CCK-8 reagent to each well and incubate for 1-4 hours in the CO₂ incubator.
- **Data Acquisition:** Measure the absorbance at 450 nm using a microplate reader.
- **Data Analysis:** Subtract the absorbance of blank wells (medium only) from all other wells. Calculate the percentage of cell viability relative to the vehicle control. Plot the percentage of cell viability against the logarithm of the inhibitor concentration and use non-linear regression to determine the IC₅₀ value.

Protocol 2: Western Blot Analysis of CDK7 Inhibition Markers

This protocol is for assessing the phosphorylation status of CDK7 downstream targets.

Materials:

- **CDK7-IN-20**
- 6-well plates
- RIPA lysis buffer with protease and phosphatase inhibitors
- BCA protein assay kit
- SDS-PAGE gels and running buffer
- PVDF membrane
- Blocking buffer (e.g., 5% non-fat milk or BSA in TBST)
- Primary antibodies (e.g., anti-p-RNA Pol II (Ser5/7), anti-total RNA Pol II, anti-p-CDK1 (Thr161), anti-total CDK1, anti-p-CDK2 (Thr160), anti-total CDK2, and a loading control like GAPDH or β -actin)

- HRP-conjugated secondary antibodies
- ECL detection reagent and imaging system

Procedure:

- Cell Treatment: Plate cells in 6-well plates and allow them to adhere. Treat with various concentrations of **CDK7-IN-20** for the desired time (e.g., 6-24 hours).
- Cell Lysis: Wash cells with ice-cold PBS and lyse with RIPA buffer.
- Protein Quantification: Determine the protein concentration of each lysate using a BCA assay.
- SDS-PAGE and Transfer: Load equal amounts of protein (e.g., 20-30 µg) onto an SDS-PAGE gel. Transfer the separated proteins to a PVDF membrane.
- Immunoblotting:
 - Block the membrane for 1 hour at room temperature.
 - Incubate with primary antibodies overnight at 4°C.
 - Wash the membrane and incubate with HRP-conjugated secondary antibody for 1 hour at room temperature.
- Detection and Analysis: Detect the signal using an ECL substrate. Quantify band intensities and normalize the phosphorylated protein levels to the total protein levels.

Protocol 3: Cell Cycle Analysis by Flow Cytometry

This protocol is for determining the effect of **CDK7-IN-20** on cell cycle distribution.

Materials:

- **CDK7-IN-20**
- 6-well plates

- PBS
- Ice-cold 70% ethanol
- Propidium Iodide (PI) staining solution with RNase A
- Flow cytometer

Procedure:

- Cell Treatment: Plate cells in 6-well plates and treat with **CDK7-IN-20** or DMSO for a duration equivalent to one cell cycle (e.g., 24 hours).
- Cell Harvesting and Fixation: Harvest cells by trypsinization and wash with PBS. While vortexing gently, add ice-cold 70% ethanol dropwise to fix the cells. Incubate at -20°C for at least 2 hours.
- Staining: Centrifuge the fixed cells, wash with PBS, and resuspend in PI staining solution. Incubate for 30 minutes at room temperature in the dark.
- Flow Cytometry Analysis: Analyze the samples on a flow cytometer, acquiring at least 10,000 events per sample.
- Data Analysis: Use cell cycle analysis software to quantify the percentage of cells in the G0/G1, S, and G2/M phases.

Troubleshooting Guide

Problem 1: No or reduced efficacy of **CDK7-IN-20** (e.g., high IC50 value).

Possible Cause	Recommended Action
Compound Degradation	Prepare a fresh stock solution of CDK7-IN-20. Ensure proper storage at -80°C in small aliquots.
Incorrect Concentration	Verify the final concentration of CDK7-IN-20 in your experiment. Perform a wider dose-response curve.
Cell Line Insensitivity	Test CDK7-IN-20 on a known sensitive cell line (e.g., HCT116, OVCAR-3) in parallel to confirm compound activity.
Insufficient Incubation Time	Increase the incubation time (e.g., 48, 72, or 96 hours) as the effects of CDK7 inhibition can be time-dependent.
Low Target Engagement	Perform a western blot to assess the phosphorylation of downstream targets like RNA Pol II CTD (Ser5/7) to confirm target engagement in your cells.

Problem 2: Inconsistent results between experiments.

Possible Cause	Recommended Action
Variability in Cell Seeding Density	Ensure accurate and consistent cell counting and seeding for each experiment.
High Cell Passage Number	Use cells within a consistent and low passage number range, as drug sensitivity can change with high passage numbers.
Inhibitor Stock Degradation	Avoid repeated freeze-thaw cycles of the stock solution by preparing and using small aliquots.

Problem 3: Significant cell death even at low concentrations.

Possible Cause	Recommended Action
High Sensitivity of the Cell Line	Your cell line may be particularly sensitive to CDK7 inhibition. Use a lower range of concentrations in your dose-response experiment.
Solvent Cytotoxicity	Ensure the final concentration of DMSO in the culture medium is low ($\leq 0.1\%$) and include a vehicle-only control to assess solvent toxicity.

Problem 4: Unexpected phenotype observed.

Possible Cause	Recommended Action
Off-Target Effects	At higher concentrations, CDK7-IN-20 may inhibit other kinases. Use the lowest effective concentration and validate findings with a second, structurally different CDK7 inhibitor or a genetic approach (e.g., siRNA/shRNA knockdown of CDK7).
Cellular Context	The effect of CDK7 inhibition can be cell-type specific. Characterize the downstream effects on CDK7 targets to confirm on-target activity in your specific cell line.

Visualizations

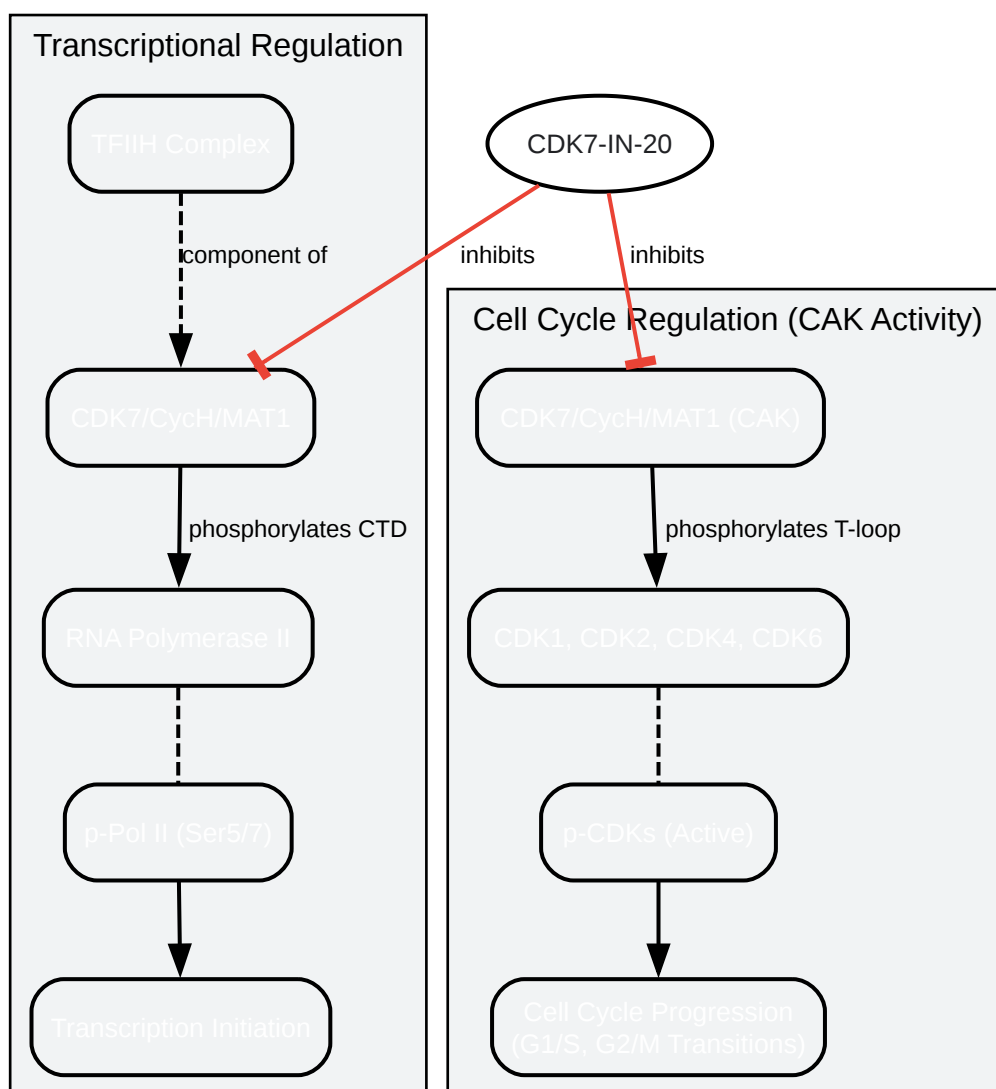

[Click to download full resolution via product page](#)

Caption: CDK7's dual role in transcription and cell cycle, and its inhibition by **CDK7-IN-20**.

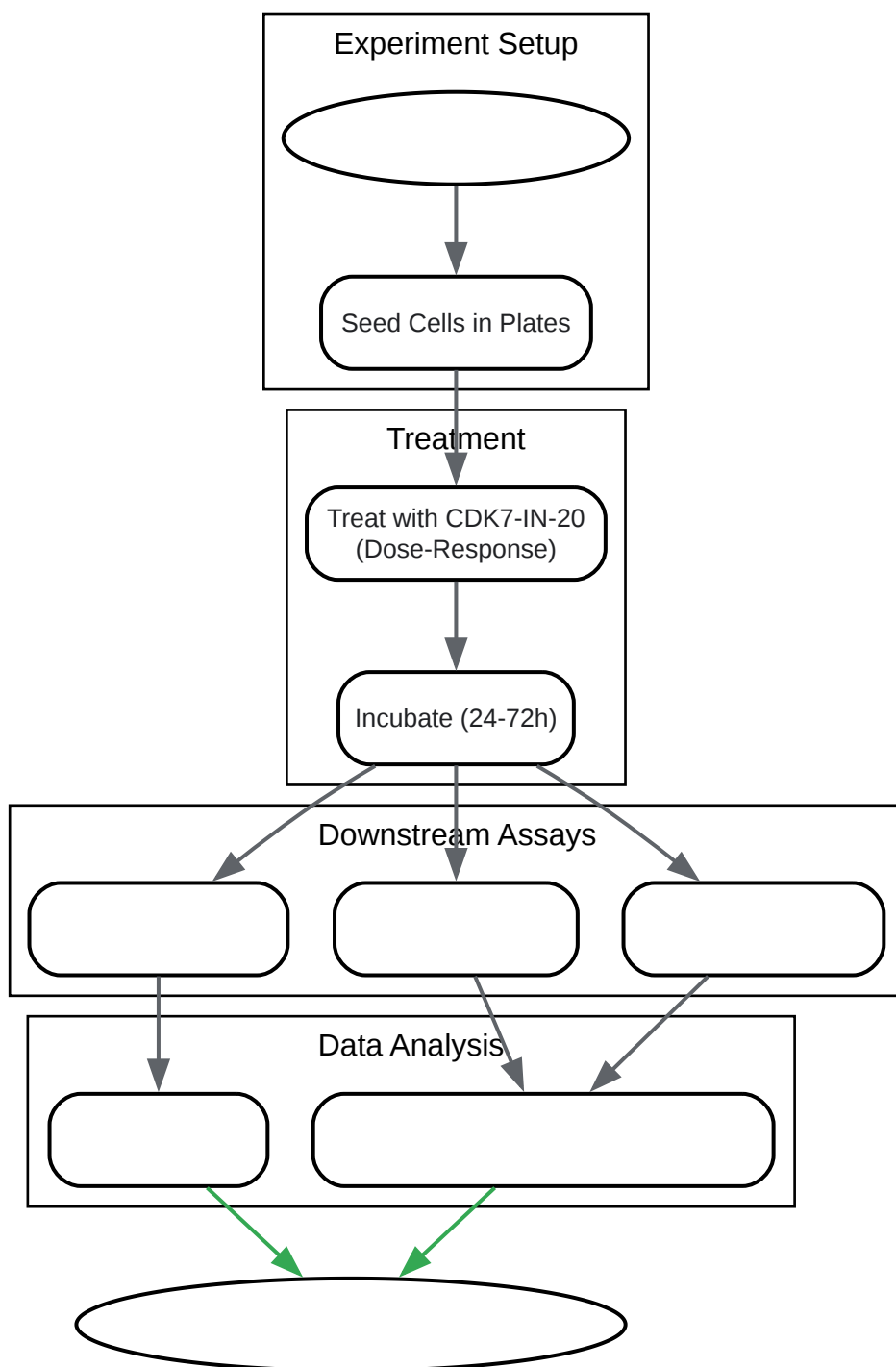

[Click to download full resolution via product page](#)

Caption: General experimental workflow for optimizing **CDK7-IN-20** concentration and assessing efficacy.

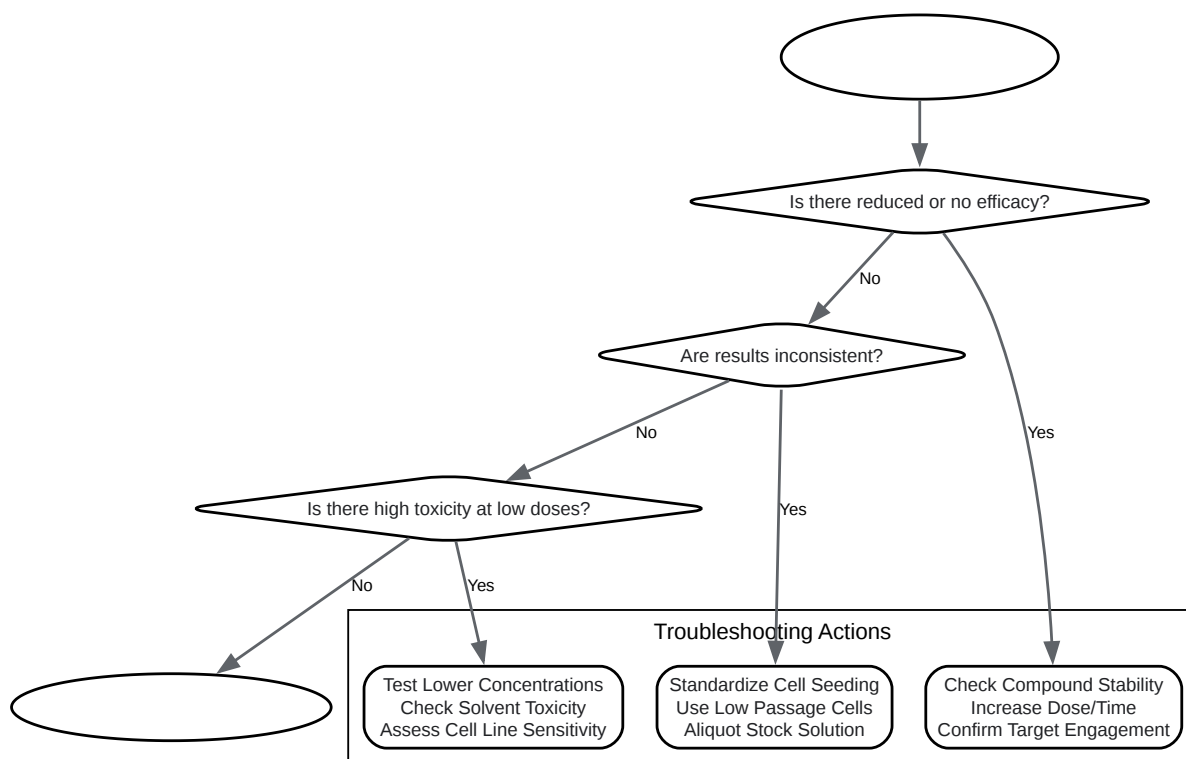

[Click to download full resolution via product page](#)

Caption: A logical workflow for troubleshooting common issues in **CDK7-IN-20** experiments.

Need Custom Synthesis?

BenchChem offers custom synthesis for rare earth carbides and specific isotopic labeling.

Email: info@benchchem.com or [Request Quote Online](#).

References

- 1. [benchchem.com](https://www.benchchem.com) [benchchem.com]

- [2. benchchem.com \[benchchem.com\]](#)
- [3. benchchem.com \[benchchem.com\]](#)
- To cite this document: BenchChem. [Technical Support Center: Optimizing CDK7-IN-20 Concentration for Efficacy]. BenchChem, [2026]. [Online PDF]. Available at: [<https://www.benchchem.com/product/b12403626/docs#technical-support-center-optimizing-cdk7-in-20-concentration-for-efficacy>]

Disclaimer & Data Validity:

The information provided in this document is for Research Use Only (RUO) and is strictly not intended for diagnostic or therapeutic procedures. While BenchChem strives to provide accurate protocols, we make no warranties, express or implied, regarding the fitness of this product for every specific experimental setup.

Technical Support: The protocols provided are for reference purposes. Unsure if this reagent suits your experiment?

Need Industrial/Bulk Grade? [Request Custom Synthesis Quote](#)

BenchChem

Our mission is to be the trusted global source of essential and advanced chemicals, empowering scientists and researchers to drive progress in science and industry.

Contact

Address: 3281 E Guasti Rd
Ontario, CA 91761, United States
Phone: (601) 213-4426
Email: info@benchchem.com

[Contact our Ph.D. Support Team for a compatibility check](#)