

# Technical Support Center: Investigating Off-Target Effects of CDK7 Inhibitors

**Author:** BenchChem Technical Support Team. **Date:** April 2026

## Compound of Interest

Compound Name: CDK7-IN-20

Cat. No.: B12403626

[Get Quote](#)

Disclaimer: Comprehensive, publicly available data on a compound specifically named "**CDK7-IN-20**" is limited. This guide utilizes data from well-characterized, selective CDK7 inhibitors such as SY-351 and YKL-5-124 as representative examples to illustrate the principles and methodologies for investigating off-target effects. The experimental approaches described are directly applicable to the study of novel CDK7 inhibitors.

## Frequently Asked Questions (FAQs)

Q1: What is CDK7 and why is it a therapeutic target?

Cyclin-dependent kinase 7 (CDK7) is a key protein that plays a dual role in two fundamental cellular processes: transcription and cell cycle progression.<sup>[1]</sup> As a component of the Transcription Factor IIH (TFIIH) complex, CDK7 phosphorylates the C-terminal domain (CTD) of RNA Polymerase II (RNAPII), a critical step for initiating and elongating transcription.<sup>[1][2]</sup> Additionally, as the catalytic subunit of the CDK-activating kinase (CAK) complex, CDK7 activates other CDKs, including CDK1, CDK2, CDK4, and CDK6, which control cell cycle checkpoints.<sup>[1][2]</sup> This dual function makes CDK7 an attractive therapeutic target in oncology.

Q2: What are the potential off-target effects of a CDK7 inhibitor?

While CDK7 inhibitors are designed for selectivity, they may interact with other kinases, especially at higher concentrations. The most likely off-targets are structurally related kinases. For instance, some CDK7 inhibitors have shown activity against CDK12 and CDK13 at higher concentrations. It is crucial to consider these potential off-target effects as CDK12 and CDK13 are also involved in transcriptional regulation.

Q3: What are the expected on-target phenotypic effects of CDK7 inhibition?

On-target inhibition of CDK7 is expected to lead to two primary cellular outcomes:

- **Transcriptional Inhibition:** Reduced phosphorylation of RNA Polymerase II leads to the suppression of transcription, particularly affecting genes with super-enhancers that are often highly expressed in cancer cells.
- **Cell Cycle Arrest:** By preventing the activation of other CDKs (like CDK1 and CDK2), CDK7 inhibition can cause the cells to arrest at different stages of the cell cycle.

## Troubleshooting Guide

Observed Issue	Potential Cause	Recommended Action
Unexpected cell death or toxicity at low concentrations.	Off-target effects on essential kinases.	<ol style="list-style-type: none"><li>1. Verify the IC50 of your CDK7 inhibitor in your specific cell line.</li><li>2. Perform a kinome-wide selectivity screen to identify potential off-targets.</li><li>3. Lower the inhibitor concentration and increase the treatment time.</li></ol>
Lack of expected phenotype (e.g., no cell cycle arrest).	<ol style="list-style-type: none"><li>1. The cell line may be resistant to CDK7 inhibition.</li><li>2. Suboptimal inhibitor concentration or treatment duration.</li></ol>	<ol style="list-style-type: none"><li>1. Confirm CDK7 expression and activity in your cell line.</li><li>2. Perform a dose-response and time-course experiment.</li><li>3. Use a positive control cell line known to be sensitive to CDK7 inhibition.</li></ol>
Inconsistent results between experiments.	<ol style="list-style-type: none"><li>1. Reagent variability.</li><li>2. Cell passage number and confluency.</li></ol>	<ol style="list-style-type: none"><li>1. Use freshly prepared inhibitor solutions.</li><li>2. Maintain consistent cell culture conditions.</li></ol>
Data suggests off-target activity.	The inhibitor may be binding to other kinases.	<ol style="list-style-type: none"><li>1. Use an inactive analog of the inhibitor as a negative control.</li><li>2. Perform rescue experiments by introducing a drug-resistant form of CDK7.</li></ol>

## Quantitative Data Summary

The following tables summarize the selectivity and target engagement data for the well-characterized CDK7 inhibitor SY-351, which can serve as a reference for evaluating novel CDK7 inhibitors.

Table 1: Kinase Selectivity of SY-351

Kinase	Inhibition at 0.2 $\mu$ M	Inhibition at 1 $\mu$ M
CDK7	>90%	>90%
CDK12	<50%	>50%
CDK13	<50%	>50%
Other (249 kinases)	<50%	Six other kinases >50%

Data from KiNativ profiling in a panel of 252 kinases.

Table 2: SY-351 Target Engagement in HL-60 Cells (1-hour treatment)

Target	EC50	EC90
CDK7	8.3 nM	39 nM
CDK12	36 nM	172 nM

This data highlights that a concentration of 50 nM SY-351 effectively engages CDK7 while minimizing the engagement of CDK12.

Table 3: IC50 Values of SY-351 Against Active Kinase Complexes

Kinase Complex	IC50
CDK7/CCNH/MAT1	23 nM
CDK2/CCNE1	321 nM
CDK9/CCNT1	226 nM
CDK12/CCNK	367 nM

This demonstrates the high selectivity of SY-351 for the CDK7 complex over other cyclin-dependent kinases.

## Key Experimental Protocols

## 1. Kinome-Wide Selectivity Profiling (e.g., KiNativ)

This method is used to assess the selectivity of an inhibitor across a broad panel of kinases.

- Principle: This assay measures the ability of a compound to compete with an ATP probe for binding to the active site of kinases in a cell lysate.
- Methodology:
  - Prepare cell lysates.
  - Incubate the lysate with a range of concentrations of the test inhibitor (e.g., **CDK7-IN-20**).
  - Add a biotinylated ATP probe that covalently binds to the active site of kinases.
  - Capture the labeled kinases on a streptavidin plate.
  - Detect the amount of captured kinase using specific antibodies.
  - The reduction in signal in the presence of the inhibitor indicates its binding affinity for that kinase.

## 2. Cellular Thermal Shift Assay (CETSA®)

CETSA® is a powerful technique to verify target engagement in intact cells and tissues.

- Principle: The binding of a ligand (inhibitor) to its target protein stabilizes the protein, leading to an increase in its melting temperature.
- Methodology:
  - Treat intact cells with the CDK7 inhibitor or a vehicle control.
  - Heat the cells at a range of temperatures.
  - Lyse the cells and separate the soluble and aggregated protein fractions by centrifugation.
  - Analyze the amount of soluble CDK7 in each sample by Western blotting or other protein detection methods.

- Plot the amount of soluble protein against temperature to generate a melting curve. A shift in the melting curve for the inhibitor-treated samples compared to the control indicates target engagement.

### 3. Western Blot Analysis for On-Target and Off-Target Pathway Modulation

This protocol assesses the functional consequences of CDK7 inhibition by measuring the phosphorylation status of its downstream substrates.

- Methodology:
  - Treat cells with the CDK7 inhibitor at various concentrations and for different durations.
  - Lyse the cells in a buffer containing protease and phosphatase inhibitors.
  - Quantify the total protein concentration.
  - Separate the proteins by SDS-PAGE and transfer them to a PVDF membrane.
  - Probe the membrane with primary antibodies against:
    - On-Target Effects: Phospho-RNAPII CTD (Ser5), Phospho-CDK1 (Thr161), Phospho-CDK2 (Thr160).
    - Potential Off-Target Effects (CDK12/13): Phospho-RNAPII CTD (Ser2).
    - Loading Control: GAPDH,  $\beta$ -actin, or Tubulin.
  - Incubate with the appropriate secondary antibodies and visualize the protein bands.

## Visualizations

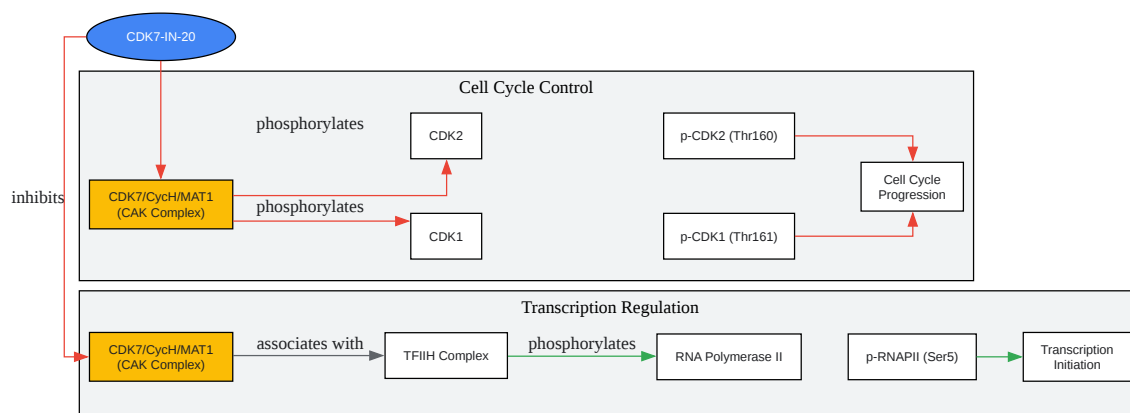

[Click to download full resolution via product page](#)

Caption: CDK7's dual role in transcription and cell cycle regulation.

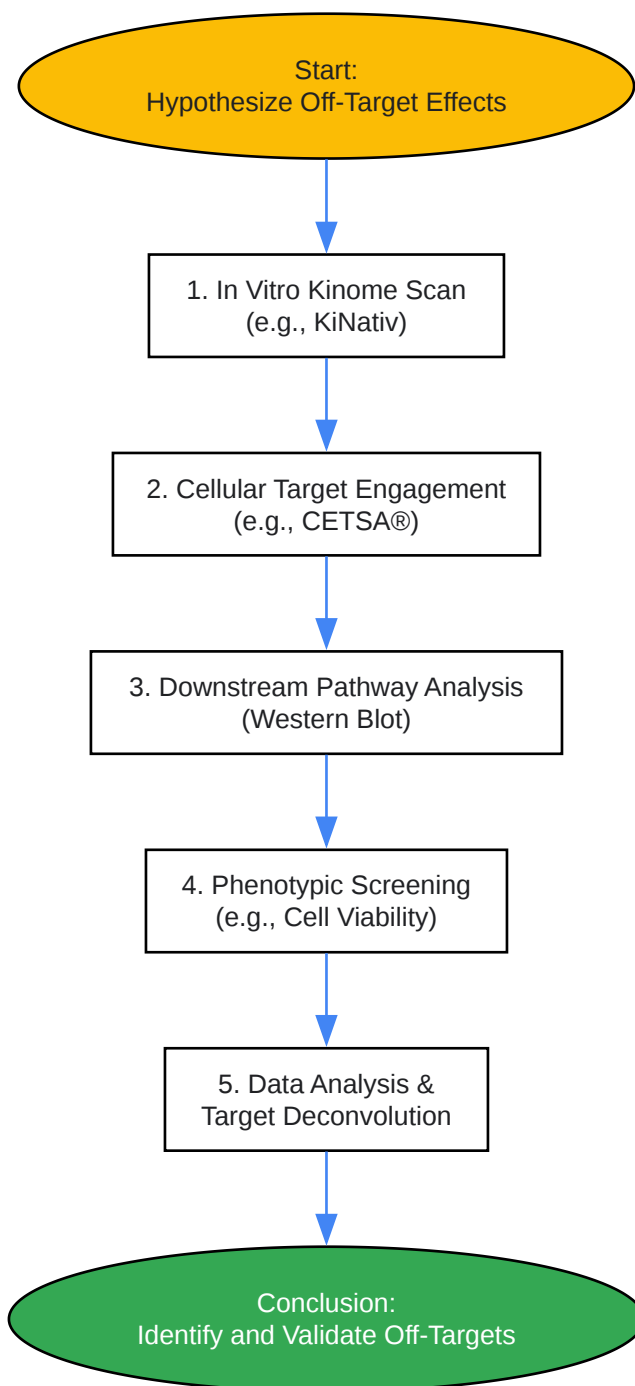

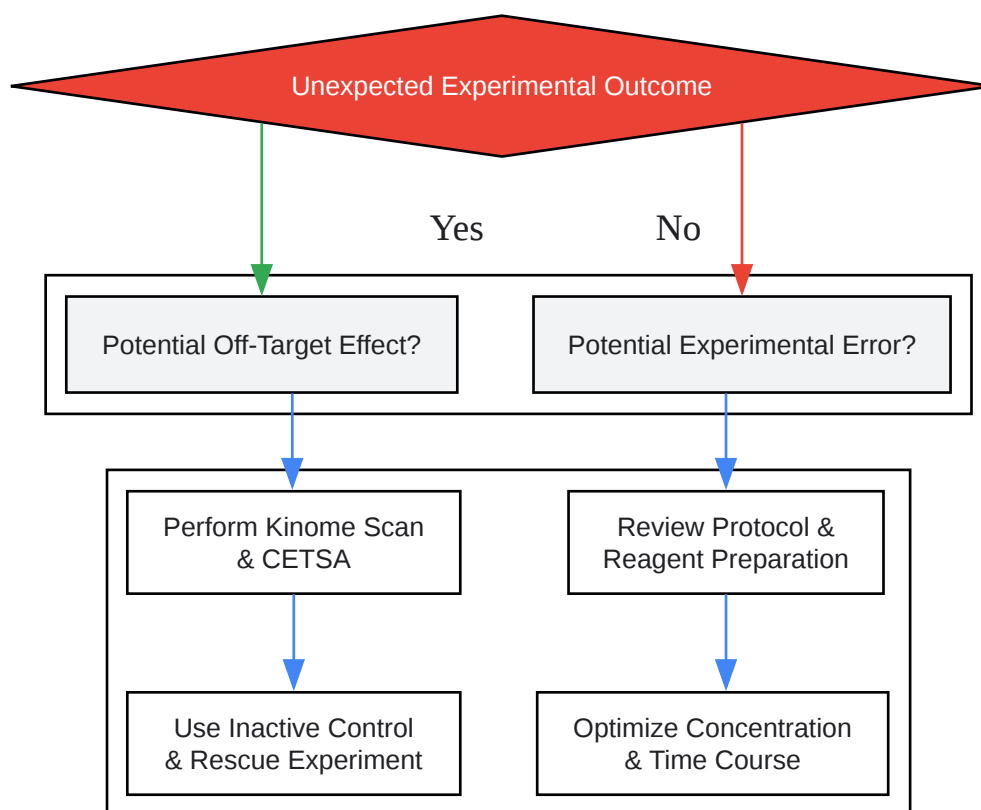

[Click to download full resolution via product page](#)

### Need Custom Synthesis?

BenchChem offers custom synthesis for rare earth carbides and specific isotopic labeling.

Email: [info@benchchem.com](mailto:info@benchchem.com) or [Request Quote Online](#).

## References

- 1. [benchchem.com](https://www.benchchem.com) [benchchem.com]
- 2. CDK7-targeted therapy effectively disrupts cell cycle progression and oncogenic signaling in head and neck cancer - PMC [pmc.ncbi.nlm.nih.gov]
- To cite this document: BenchChem. [Technical Support Center: Investigating Off-Target Effects of CDK7 Inhibitors]. BenchChem, [2026]. [Online PDF]. Available at: [https://www.benchchem.com/product/b12403626/docs#technical-support-center-investigating-off-target-effects-of-cdk7-inhibitors]

**Disclaimer & Data Validity:**

The information provided in this document is for Research Use Only (RUO) and is strictly not intended for diagnostic or therapeutic procedures. While BenchChem strives to provide accurate protocols, we make no warranties, express or implied, regarding the fitness of this product for every specific experimental setup.

**Technical Support:** The protocols provided are for reference purposes. Unsure if this reagent suits your experiment?

**Need Industrial/Bulk Grade?** [Request Custom Synthesis Quote](#)

## BenchChem

Our mission is to be the trusted global source of essential and advanced chemicals, empowering scientists and researchers to drive progress in science and industry.

### Contact

Address: 3281 E Guasti Rd  
Ontario, CA 91761, United States  
Phone: (601) 213-4426  
Email: [info@benchchem.com](mailto:info@benchchem.com)

[Contact our Ph.D. Support Team for a compatibility check](#)