

"P-gp modulator 3" solubility issues in aqueous buffer

Author: BenchChem Technical Support Team. **Date:** April 2026

Compound of Interest

Compound Name: P-gp modulator 3

Cat. No.: B12403519

[Get Quote](#)

Technical Support Center: P-gp Modulator 3

This technical support center provides troubleshooting guidance and frequently asked questions (FAQs) for researchers and scientists encountering solubility issues with **P-gp Modulator 3** in aqueous buffers.

Frequently Asked Questions (FAQs)

Q1: What is **P-gp Modulator 3** and why is its aqueous solubility a concern?

P-gp Modulator 3 is a potent, small molecule inhibitor of the P-glycoprotein (P-gp) efflux pump. P-gp is a transmembrane protein that actively transports a wide variety of substrates out of cells, contributing to multidrug resistance in cancer and limiting the oral bioavailability of many drugs.^{[1][2]} Like many potent P-gp modulators, **P-gp Modulator 3** is a lipophilic compound with inherently low aqueous solubility.^{[3][4]} This poor solubility can pose significant challenges during in vitro and in vivo experiments, as achieving and maintaining a sufficient concentration in aqueous media is critical for its biological activity.

Q2: What are the recommended initial solvents for preparing a stock solution of **P-gp Modulator 3**?

For preparing a high-concentration stock solution, it is recommended to use an organic solvent. The choice of solvent will depend on the specific experimental requirements and cell tolerance. Commonly used organic solvents for poorly soluble small molecules include:

- Dimethyl Sulfoxide (DMSO)
- Ethanol (EtOH)
- N,N-Dimethylformamide (DMF)

It is crucial to prepare a high-concentration stock solution (e.g., 10-50 mM) in the chosen organic solvent.[3] However, the final concentration of the organic solvent in the aqueous experimental medium should be kept to a minimum (typically <0.5%) to avoid solvent-induced cellular toxicity or off-target effects.

Q3: My **P-gp Modulator 3** precipitates out of solution when I dilute my DMSO stock into my aqueous assay buffer. What can I do?

Precipitation upon dilution of a concentrated organic stock solution into an aqueous buffer is a common problem for hydrophobic compounds. This occurs because the compound is no longer soluble as the concentration of the organic co-solvent decreases. Several strategies can be employed to overcome this issue, as detailed in the troubleshooting guide below.

Troubleshooting Guide: Solubility Issues with **P-gp Modulator 3**

This guide provides a systematic approach to troubleshooting common solubility problems encountered with **P-gp Modulator 3**.

Problem 1: Precipitate Formation Upon Dilution

Observation: A visible precipitate forms immediately or over a short period after diluting the **P-gp Modulator 3** stock solution into the aqueous experimental buffer.

Troubleshooting Steps:

- **Optimize Co-solvent Concentration:** While aiming for a low final concentration, a slightly higher but still non-toxic concentration of the organic solvent might be necessary. Test a range of final DMSO (or other solvent) concentrations to find the optimal balance between solubility and cell viability.
- **Utilize a Surfactant:** Low concentrations of non-ionic surfactants can aid in solubilizing hydrophobic compounds by forming micelles.
- **Employ Cyclodextrins:** Cyclodextrins are cyclic oligosaccharides that can encapsulate hydrophobic molecules, forming inclusion complexes that are more water-soluble.
- **Prepare a Lipid-Based Formulation:** For in vivo studies or specific in vitro models, formulating **P-gp Modulator 3** in a lipid-based system like a self-emulsifying drug delivery system (SEDDS) can significantly improve its solubility and bioavailability.

Table 1: Comparison of Solubility Enhancement Strategies

Strategy	Typical Concentration	Advantages	Disadvantages
Co-solvent (e.g., DMSO)	0.1% - 1% (v/v)	Simple to implement.	Potential for cellular toxicity at higher concentrations.
Surfactant (e.g., Tween® 80)	0.01% - 0.1% (v/v)	Effective at low concentrations.	Can interfere with some biological assays; potential for cell lysis at higher concentrations.
Cyclodextrin (e.g., HP-β-CD)	1% - 5% (w/v)	Low cellular toxicity.	Can sometimes extract cholesterol from cell membranes.
Lipid-Based Formulation	Varies	Can significantly enhance bioavailability.	More complex to prepare; may not be suitable for all in vitro assays.

Problem 2: Inconsistent Assay Results

Observation: High variability in experimental results, potentially due to inconsistent concentrations of the soluble fraction of **P-gp Modulator 3**.

Troubleshooting Steps:

- **Pre-warm the Buffer:** Gently warming the aqueous buffer before adding the **P-gp Modulator 3** stock solution can sometimes improve solubility. Ensure the final temperature is appropriate for your experimental setup.
- **Vortex During Dilution:** Vigorously vortex the aqueous buffer while slowly adding the stock solution to promote rapid and uniform mixing, which can prevent localized high concentrations that are prone to precipitation.
- **Sonication:** Brief sonication of the final solution in a water bath sonicator can help to break down small, insoluble aggregates and improve dissolution.
- **Filtration:** After attempting to dissolve the compound, filter the solution through a 0.22 μm filter to remove any undissolved precipitate. This ensures that you are working with a truly soluble fraction, although the final concentration will be lower than the nominal concentration and should be analytically determined if possible.

Experimental Protocols

Protocol 1: Preparation of P-gp Modulator 3 Working Solution using a Co-solvent

- Prepare a 10 mM stock solution of **P-gp Modulator 3** in 100% DMSO.
- Gently warm the aqueous assay buffer to 37°C.
- While vortexing the warm buffer, slowly add the required volume of the 10 mM stock solution to achieve the desired final concentration. Ensure the final DMSO concentration is below 0.5%.
- Visually inspect the solution for any signs of precipitation.

- If the solution remains clear, it is ready for use. If a precipitate forms, consider using one of the alternative methods below.

Protocol 2: Preparation of P-gp Modulator 3 Working Solution using a Surfactant

- Prepare a 10 mM stock solution of **P-gp Modulator 3** in 100% DMSO.
- Prepare the aqueous assay buffer containing a low concentration of a non-ionic surfactant (e.g., 0.05% Tween® 80).
- While vortexing the surfactant-containing buffer, slowly add the **P-gp Modulator 3** stock solution to achieve the desired final concentration.
- Continue to vortex for 1-2 minutes to ensure thorough mixing.
- Visually inspect for precipitation.

Visualizations

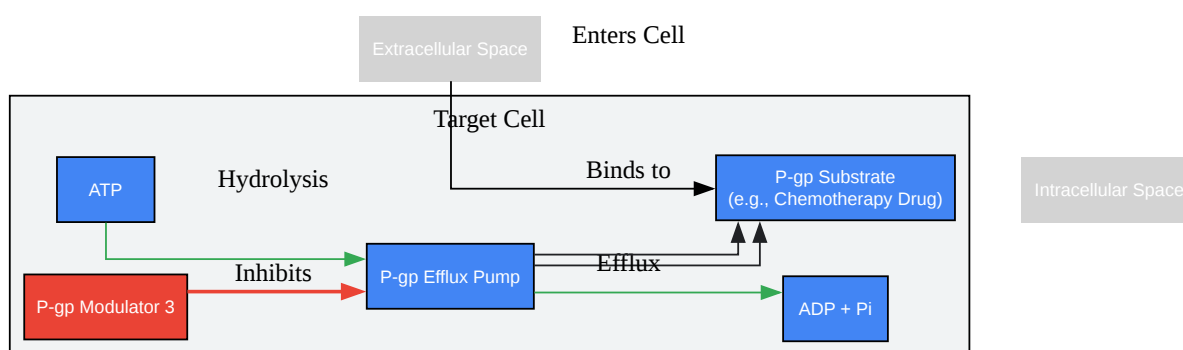

[Click to download full resolution via product page](#)

Caption: Mechanism of P-gp inhibition by **P-gp Modulator 3**.

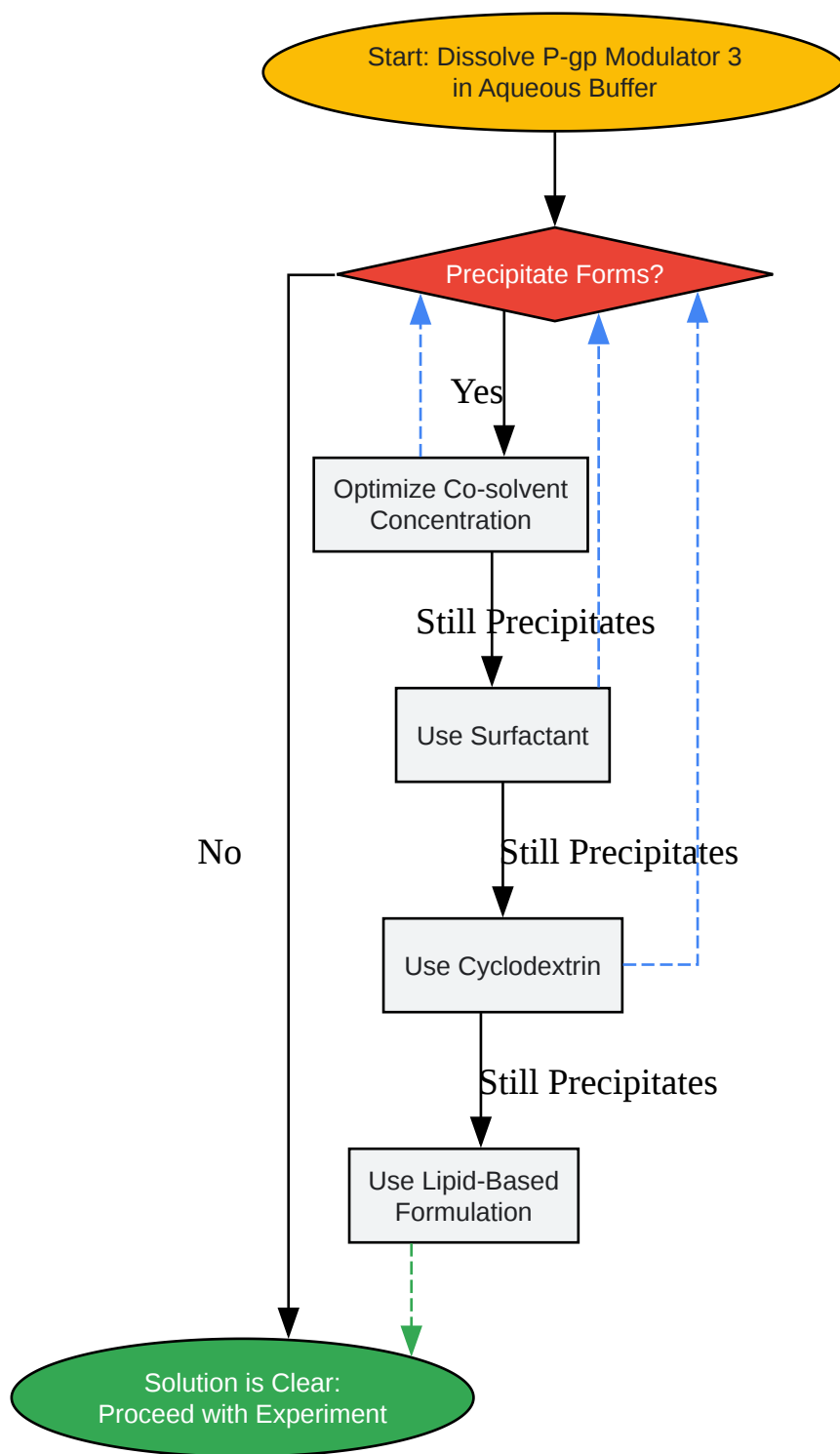

[Click to download full resolution via product page](#)

Caption: Troubleshooting workflow for **P-gp Modulator 3** solubility issues.

Need Custom Synthesis?

BenchChem offers custom synthesis for rare earth carbides and specific isotopic labeling.

Email: info@benchchem.com or [Request Quote Online](#).

References

- 1. P-glycoprotein Inhibition for Optimal Drug Delivery - PMC [[pmc.ncbi.nlm.nih.gov](https://pubmed.ncbi.nlm.nih.gov/)]
- 2. What are P-gp modulators and how do they work? [synapse.patsnap.com]
- 3. [benchchem.com](https://www.benchchem.com) [[benchchem.com](https://www.benchchem.com)]
- 4. Structural characteristics of compounds that modulate P-glycoprotein-associated multidrug resistance - PubMed [pubmed.ncbi.nlm.nih.gov]
- To cite this document: BenchChem. ["P-gp modulator 3" solubility issues in aqueous buffer]. BenchChem, [2026]. [Online PDF]. Available at: [<https://www.benchchem.com/product/b12403519/docs#p-gp-modulator-3-solubility-issues-in-aqueous-buffer>]

Disclaimer & Data Validity:

The information provided in this document is for Research Use Only (RUO) and is strictly not intended for diagnostic or therapeutic procedures. While BenchChem strives to provide accurate protocols, we make no warranties, express or implied, regarding the fitness of this product for every specific experimental setup.

Technical Support: The protocols provided are for reference purposes. Unsure if this reagent suits your experiment?

Need Industrial/Bulk Grade? [Request Custom Synthesis Quote](#)

BenchChem

Our mission is to be the trusted global source of essential and advanced chemicals, empowering scientists and researchers to drive progress in science and industry.

Contact

Address: 3281 E Guasti Rd

Ontario, CA 91761, United States

Phone: (601) 213-4426

Email: info@benchchem.com

[Contact our Ph.D. Support Team for a compatibility check](#)