

# Comparative Analysis of GluN2B-Selective Modulators: A Guide for Researchers

**Author:** BenchChem Technical Support Team. **Date:** April 2026

## Compound of Interest

Compound Name: *NMDA receptor modulator 5*

Cat. No.: *B12403777*

[Get Quote](#)

For researchers, scientists, and drug development professionals, the selective modulation of the GluN2B subunit of the N-methyl-D-aspartate (NMDA) receptor represents a significant area of therapeutic interest for a variety of neurological and psychiatric disorders. This guide provides an objective comparison of prominent GluN2B-selective modulators, including both negative allosteric modulators (NAMs) and positive allosteric modulators (PAMs), supported by experimental data and detailed methodologies.

The NMDA receptor, a crucial component of excitatory neurotransmission in the central nervous system, is a heterotetrameric ion channel. The subunit composition, particularly the type of GluN2 subunit (A-D), dictates the receptor's pharmacological and biophysical properties. The GluN2B subunit is of particular interest due to its role in synaptic plasticity, learning, and memory, and its dysregulation has been implicated in conditions such as depression, neuropathic pain, and neurodegenerative diseases. This guide will delve into a comparative analysis of compounds designed to selectively modulate GluN2B-containing NMDA receptors.

## Quantitative Comparison of GluN2B-Selective Modulators

The following table summarizes the quantitative data for a selection of well-characterized GluN2B-selective modulators. Potency is a key parameter in drug development, and for NAMs, it is typically expressed as the half-maximal inhibitory concentration (IC<sub>50</sub>), while for PAMs, it is expressed as the half-maximal effective concentration (EC<sub>50</sub>). Selectivity is determined by comparing the potency of a compound for the GluN2B subunit to its potency for other NMDA receptor subunits, particularly GluN2A.

Modulator Class	Compound	Potency (IC50/EC50) for GluN2B	Selectivity (Fold vs. GluN2A)	Pharmacokinetic Profile Highlights
Negative Allosteric Modulators (NAMs)	Ifenprodil	IC50: ~0.34 $\mu$ M[1]	~400-fold[1]	Subject to rapid biotransformation.[2]
Traxoprodil (CP-101,606)	IC50: ~10 nM	Highly selective for GluN2B.[3][4]	Oral bioavailability is nonlinear and dose-dependent in extensive metabolizers of CYP2D6.[5] Elimination is more rapid in extensive metabolizers.[6]	
Ro 25-6981	IC50: 9 nM[5][6][7]	>5000-fold[7]	Well-tolerated in animal models.[8][9]	
CERC-301 (MK-0657)	IC50: 3.6 nM, Ki: 8.1 nM[10][11][12]	>1000-fold selectivity for GluN2B.[13]	Orally bioavailable with a terminal half-life of 12-17 hours in humans.[10][12]	
Positive Allosteric Modulators (PAMs)	Pregnenolone Sulfate	EC50: ~33 $\mu$ M[14]	Potentiates both GluN2A and GluN2B-containing receptors.[13]	Endogenous neurosteroid.
Spermine	EC50: in the hundreds of $\mu$ M	Specific for diheteromeric	Endogenous polyamine with	

	range	GluN2B-containing NMDARs.	multiple biological targets.
Tobramycin	-	GluN2B-selective.[13]	Aminoglycoside antibiotic.

## Signaling Pathways and Experimental Workflows

To visualize the context in which these modulators act and the processes by which they are evaluated, the following diagrams are provided.

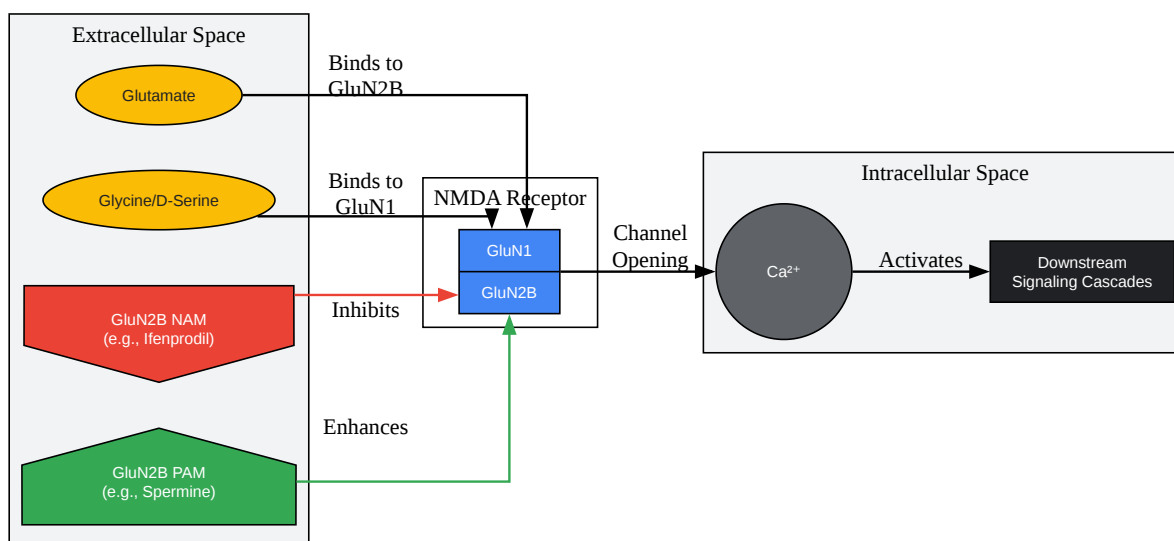

[Click to download full resolution via product page](#)

NMDA Receptor signaling and modulator binding sites.

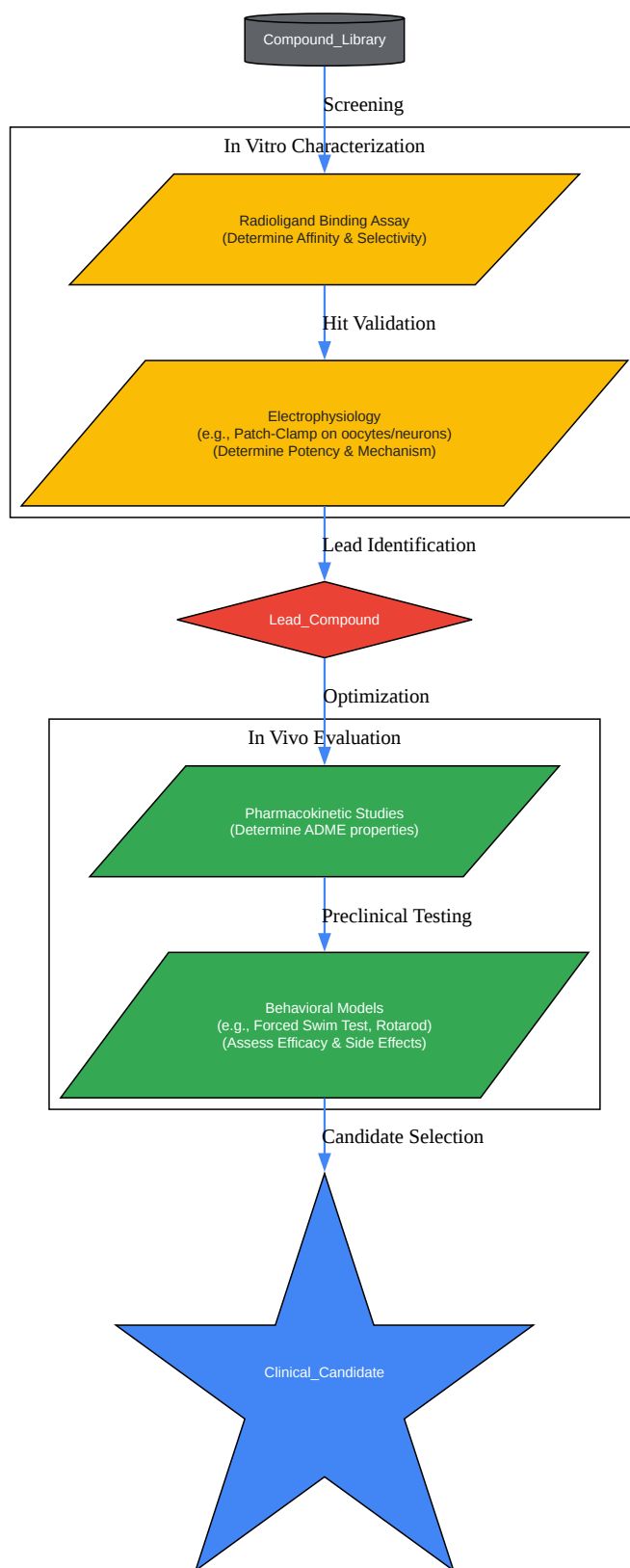

[Click to download full resolution via product page](#)

Typical workflow for screening GluN2B modulators.

## Detailed Experimental Protocols

Objective and reproducible experimental data are the cornerstone of drug discovery. Below are detailed methodologies for key experiments cited in the characterization of GluN2B-selective modulators.

### Radioligand Binding Assay

This assay is fundamental for determining the binding affinity ( $K_i$ ) of a test compound to the GluN2B receptor and its selectivity over other receptor subtypes.

- Objective: To measure the displacement of a specific radiolabeled ligand from the GluN2B receptor by an unlabeled test compound.
- Materials:
  - Cell membranes expressing recombinant human NMDA receptors (e.g., GluN1/GluN2B and GluN1/GluN2A).
  - Radioligand specific for the GluN2B subunit (e.g., [ $^3\text{H}$ ]Ro 25-6981 or [ $^3\text{H}$ ]ifenprodil).
  - Unlabeled test compound.
  - Binding buffer (e.g., 50 mM Tris-HCl, pH 7.4).
  - 96-well filter plates with GF/B filters.
  - Scintillation cocktail and liquid scintillation counter.
- Procedure:
  - Prepare serial dilutions of the unlabeled test compound.
  - In a 96-well plate, add the cell membranes, the radioligand at a fixed concentration (typically at or below its  $K_d$  value), and varying concentrations of the test compound.
  - To determine non-specific binding, a separate set of wells should contain a high concentration of an unlabeled reference compound.

- Incubate the plate at room temperature for a sufficient time to reach equilibrium (e.g., 60-120 minutes).
- Terminate the binding reaction by rapid filtration through the filter plates using a cell harvester.
- Wash the filters multiple times with ice-cold binding buffer to remove unbound radioligand.
- Dry the filters, add scintillation cocktail, and quantify the radioactivity using a liquid scintillation counter.
- Data Analysis:
  - Calculate specific binding by subtracting non-specific binding from total binding.
  - Plot the percentage of specific binding against the logarithm of the test compound concentration.
  - Determine the IC50 value using non-linear regression analysis.
  - Calculate the Ki value using the Cheng-Prusoff equation:  $K_i = IC_{50} / (1 + [L]/K_d)$ , where [L] is the concentration of the radioligand and Kd is its dissociation constant.

## Whole-Cell Patch-Clamp Electrophysiology

This technique allows for the functional characterization of how a modulator affects the ion channel activity of the NMDA receptor.

- Objective: To measure the effect of a test compound on NMDA receptor-mediated currents in a cellular system.
- Materials:
  - Xenopus oocytes or mammalian cell lines (e.g., HEK293) expressing specific NMDA receptor subunit combinations.
  - Patch-clamp rig including an amplifier, micromanipulator, and data acquisition system.

- Borosilicate glass pipettes.
- Extracellular solution containing NMDA receptor agonists (glutamate and glycine/D-serine) and the test compound.
- Intracellular solution for the patch pipette.
- Procedure:
  - Prepare cells expressing the desired NMDA receptor subunits.
  - Pull glass pipettes to a resistance of 3-7 M $\Omega$  when filled with intracellular solution.
  - Establish a gigaohm seal between the pipette tip and the cell membrane.
  - Rupture the cell membrane to achieve the whole-cell configuration.
  - Clamp the cell membrane potential at a holding potential (e.g., -70 mV).
  - Perfuse the cell with an extracellular solution containing agonists to evoke NMDA receptor currents.
  - Apply the test compound at various concentrations and measure the change in the amplitude of the agonist-evoked current.
- Data Analysis:
  - Measure the peak amplitude of the current in the absence and presence of the test compound.
  - Normalize the current in the presence of the compound to the control current.
  - Plot the normalized current as a function of the compound concentration.
  - Fit the data with a concentration-response curve to determine the IC<sub>50</sub> (for NAMs) or EC<sub>50</sub> (for PAMs).

## In Vivo Behavioral Models

Animal models are crucial for assessing the therapeutic potential and potential side effects of GluN2B modulators.

- Objective: To evaluate the antidepressant-like properties of a test compound in rodents.
- Procedure:
  - Administer the test compound or vehicle to the animals (e.g., mice or rats) at a predetermined time before the test.
  - Place each animal individually in a transparent cylinder filled with water (23-25°C) from which it cannot escape.
  - Record the animal's behavior for a set period (e.g., 6 minutes).
  - Score the duration of immobility during the last 4 minutes of the test. A decrease in immobility time is indicative of an antidepressant-like effect.
- Objective: To assess the effect of a test compound on motor coordination and balance, which can be an indicator of potential side effects.
- Procedure:
  - Train the animals to stay on a rotating rod (rotarod) at a constant or accelerating speed.
  - Administer the test compound or vehicle.
  - At a specific time point after administration, place the animal back on the rotarod.
  - Record the latency to fall from the rod. A decrease in the time spent on the rod suggests impaired motor coordination.

This guide provides a foundational comparison of GluN2B-selective modulators. The selection of a particular compound for further research and development will depend on a careful consideration of its potency, selectivity, pharmacokinetic properties, and in vivo efficacy and safety profile. The provided experimental protocols offer a starting point for the robust and reproducible characterization of novel GluN2B modulators.

### Need Custom Synthesis?

BenchChem offers custom synthesis for rare earth carbides and specific isotopic labeling.

Email: [info@benchchem.com](mailto:info@benchchem.com) or [Request Quote Online](#).

## References

- 1. Metabolism studies of ifenprodil, a potent GluN2B receptor antagonist - PubMed [[pubmed.ncbi.nlm.nih.gov](https://pubmed.ncbi.nlm.nih.gov)]
- 2. [youtube.com](https://youtube.com) [[youtube.com](https://youtube.com)]
- 3. Traxoprodil - Wikipedia [[en.wikipedia.org](https://en.wikipedia.org)]
- 4. Absolute oral bioavailability of traxoprodil in cytochrome P450 2D6 extensive and poor metabolisers - PubMed [[pubmed.ncbi.nlm.nih.gov](https://pubmed.ncbi.nlm.nih.gov)]
- 5. [researchgate.net](https://researchgate.net) [[researchgate.net](https://researchgate.net)]
- 6. [pure.johnshopkins.edu](https://pure.johnshopkins.edu) [[pure.johnshopkins.edu](https://pure.johnshopkins.edu)]
- 7. [researchgate.net](https://researchgate.net) [[researchgate.net](https://researchgate.net)]
- 8. Effects of the GluN2B-NMDA receptor antagonist Ro 25-6981 on two types of behavioral flexibility in rats - PubMed [[pubmed.ncbi.nlm.nih.gov](https://pubmed.ncbi.nlm.nih.gov)]
- 9. Positive allosteric modulators that target NMDA receptors rectify loss-of-function GRIN variants associated with neurological and neuropsychiatric disorders - PMC [[pmc.ncbi.nlm.nih.gov](https://pmc.ncbi.nlm.nih.gov)]
- 10. Receptor Binding Assays for HTS and Drug Discovery - Assay Guidance Manual - NCBI Bookshelf [[ncbi.nlm.nih.gov](https://ncbi.nlm.nih.gov)]
- 11. [chem.uwec.edu](https://chem.uwec.edu) [[chem.uwec.edu](https://chem.uwec.edu)]
- 12. [biophysics-reports.org](https://biophysics-reports.org) [[biophysics-reports.org](https://biophysics-reports.org)]
- 13. [docs.axolbio.com](https://docs.axolbio.com) [[docs.axolbio.com](https://docs.axolbio.com)]
- 14. Rotarod Protocol - IMPReSS [[web.mousephenotype.org](https://web.mousephenotype.org)]
- To cite this document: BenchChem. [Comparative Analysis of GluN2B-Selective Modulators: A Guide for Researchers]. BenchChem, [2026]. [Online PDF]. Available at: [<https://www.benchchem.com/product/b12403777/docs#comparative-analysis-of-gluN2b-selective-modulators-a-guide-for-researchers>]

**Disclaimer & Data Validity:**

The information provided in this document is for Research Use Only (RUO) and is strictly not intended for diagnostic or therapeutic procedures. While BenchChem strives to provide accurate protocols, we make no warranties, express or implied, regarding the fitness of this product for every specific experimental setup.

**Technical Support:** The protocols provided are for reference purposes. Unsure if this reagent suits your experiment?

**Need Industrial/Bulk Grade?** [Request Custom Synthesis Quote](#)

## BenchChem

Our mission is to be the trusted global source of essential and advanced chemicals, empowering scientists and researchers to drive progress in science and industry.

### Contact

Address: 3281 E Guasti Rd  
Ontario, CA 91761, United States  
Phone: (601) 213-4426  
Email: [info@benchchem.com](mailto:info@benchchem.com)

[Contact our Ph.D. Support Team for a compatibility check](#)