

Experimental Guide for Using SphK2-IN-2 in Neuroscience Research

Author: BenchChem Technical Support Team. **Date:** April 2026

Compound of Interest

Compound Name: SphK2-IN-2

Cat. No.: B12401688

[Get Quote](#)

For Researchers, Scientists, and Drug Development Professionals

Application Notes and Protocols

This document provides a detailed guide for the experimental use of **SphK2-IN-2**, a selective inhibitor of Sphingosine Kinase 2 (SphK2), in the field of neuroscience. SphK2 is a critical enzyme in the sphingolipid metabolic pathway, catalyzing the formation of the signaling lipid sphingosine-1-phosphate (S1P).[1][2] Dysregulation of the SphK2/S1P signaling axis has been implicated in the pathogenesis of various neurodegenerative diseases, including Alzheimer's, Parkinson's, and Huntington's disease, as well as in the response to ischemic stroke.[2][3][4] **SphK2-IN-2** and its analogs, such as ABC294640, offer a powerful tool to investigate the therapeutic potential of targeting this pathway.

These notes provide protocols for in vitro studies using neuronal cell lines and primary neurons, covering essential techniques such as cell culture, viability assays, and protein analysis.

Quantitative Data Summary

The following tables summarize key quantitative data for SphK2 inhibitors, primarily focusing on ABC294640, a well-characterized **SphK2-IN-2** compound.

Table 1: In Vitro Inhibitory Activity of SphK2 Inhibitors

Compound	Target	Cell Line/System	IC50 / Ki	Reference(s)
ABC294640	SphK2	Recombinant Human	Ki = 9.8 μ M	[5]
ABC294640	SphK2	Recombinant Human	IC50 \approx 60 μ M	[6]
ABC294640	Endogenous Na ⁺ currents	Hippocampal Neurons	IC50 = 29.32 \pm 5.12 μ M	[7]
ABC294640	Endogenous Na ⁺ currents	SH-SY5Y Cells	IC50 = 34.12 \pm 3.8 μ M	[7]
ABC294640	Endogenous K ⁺ currents	SH-SY5Y Cells	IC50 = 1.57 \pm 0.50 μ M	[7]
K145	SphK2	Biochemical Assay	IC50 = 4.3 μ M, Ki = 6.4 μ M	[8]

Table 2: Effects of SphK2 Inhibition on Neuronal Cell Proliferation and Viability

Cell Line	Treatment	Concentration	Duration	Effect	Reference(s)
SH-SY5Y	ABC294640	10 μ M	Not Specified	Suppression of action potential firing	[7]
PC12	Sphingosine (PKC inhibitor)	2.5-5 μ M	Not Specified	Reversible inhibition of NGF-induced neurite outgrowth	[9]
Non-small cell lung cancer cell lines	ABC294640	7.0–8.0 μ M	Not Specified	Dose-dependent reduction in proliferation	[10]
Cholangiocarcinoma cell lines	ABC294640	36.3 - 48.6 μ M	72 hours	Dose-dependent growth inhibition	[11]

Signaling Pathway

The SphK2/S1P signaling pathway plays a multifaceted role in neuronal cells. SphK2 is predominantly localized in the nucleus, mitochondria, and endoplasmic reticulum.[2] Nuclear SphK2-generated S1P can inhibit histone deacetylases (HDACs), thereby influencing gene expression. In mitochondria, SphK2 is involved in regulating apoptosis. The overall pathway can impact cell survival, apoptosis, and neuroinflammation, making it a critical target in neurodegenerative disease research.

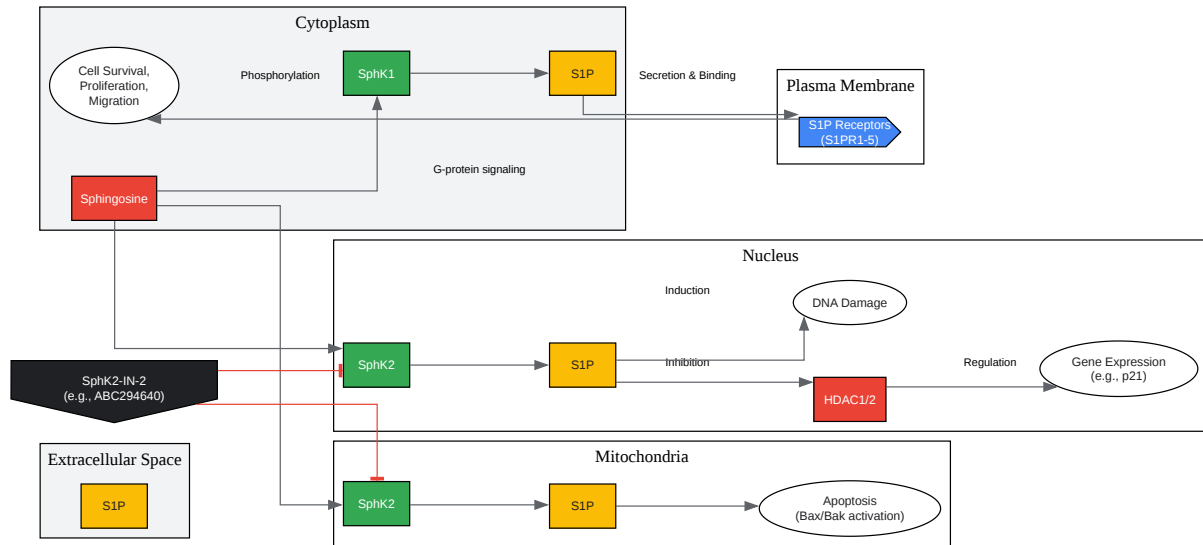

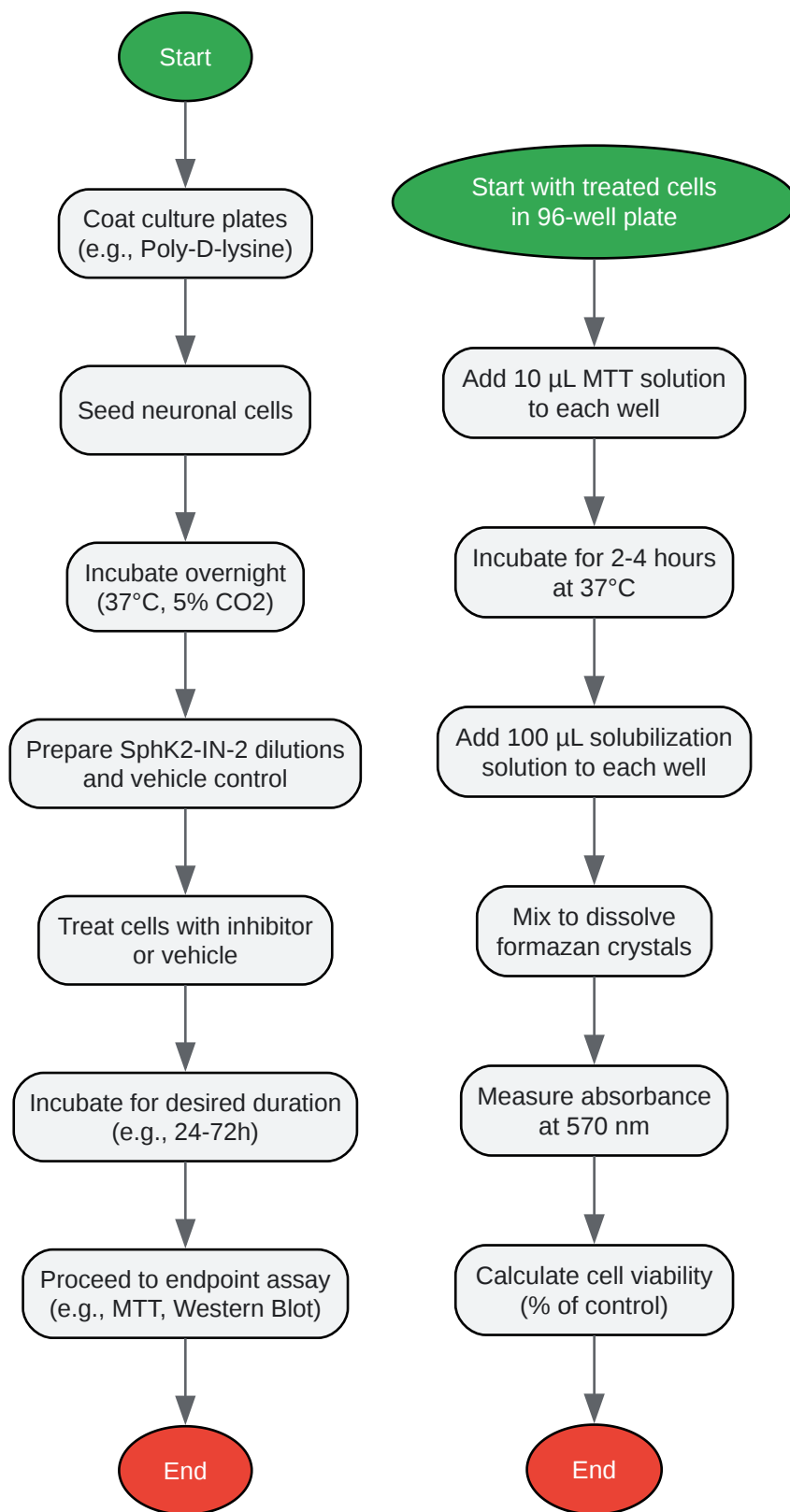

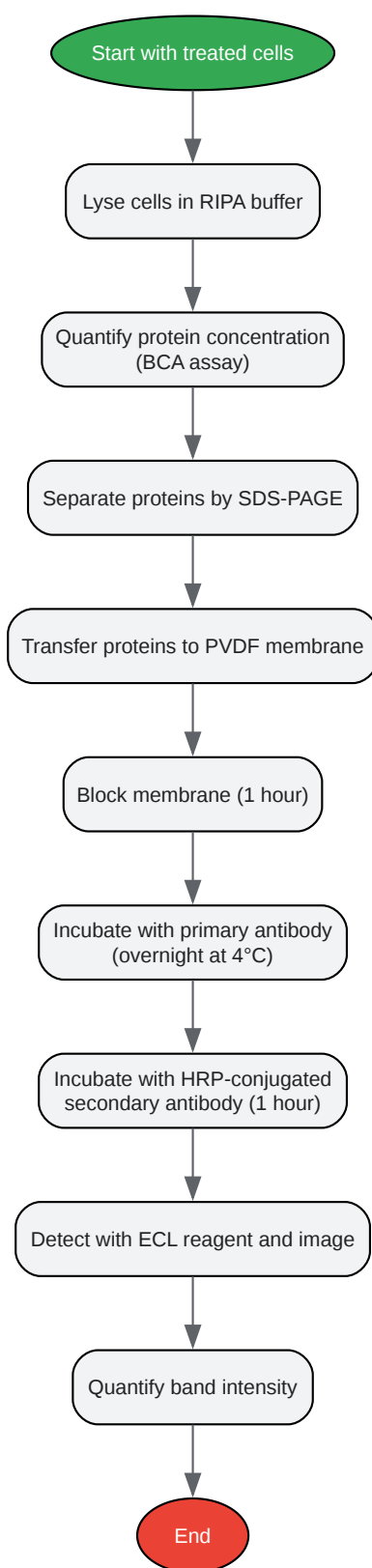

[Click to download full resolution via product page](#)

Need Custom Synthesis?

BenchChem offers custom synthesis for rare earth carbides and specific isotopic labeling.

Email: info@benchchem.com or [Request Quote Online](#).

References

- [1. What are SPHK2 inhibitors and how do they work? \[synapse.patsnap.com\]](#)
- [2. The Functional Role of Sphingosine Kinase 2 - PMC \[pmc.ncbi.nlm.nih.gov\]](#)
- [3. researchgate.net \[researchgate.net\]](#)
- [4. Frontiers | The Functional Role of Sphingosine Kinase 2 \[frontiersin.org\]](#)
- [5. The Sphingosine Kinase 2 Inhibitor ABC294640 Reduces the Growth of Prostate Cancer Cells and Results in Accumulation of Dihydroceramides In Vitro and In Vivo - PubMed \[pubmed.ncbi.nlm.nih.gov\]](#)
- [6. Pharmacology and Antitumor Activity of ABC294640, a Selective Inhibitor of Sphingosine Kinase-2 - PMC \[pmc.ncbi.nlm.nih.gov\]](#)
- [7. Sphingosine kinase 2 inhibitor ABC294640 suppresses neuronal excitability and inhibits multiple endogenously and exogenously expressed voltage-gated ion channels in cultured cells - PMC \[pmc.ncbi.nlm.nih.gov\]](#)
- [8. selleckchem.com \[selleckchem.com\]](#)
- [9. Suppression of nerve growth factor-directed neurite outgrowth in PC12 cells by sphingosine, an inhibitor of protein kinase C - PubMed \[pubmed.ncbi.nlm.nih.gov\]](#)
- [10. The sphingosine kinase 2 inhibitor ABC294640 displays anti-non-small cell lung cancer activities in vitro and in vivo - PMC \[pmc.ncbi.nlm.nih.gov\]](#)
- [11. Antitumor effect of the novel sphingosine kinase 2 inhibitor ABC294640 is enhanced by inhibition of autophagy and by sorafenib in human cholangiocarcinoma cells - PMC \[pmc.ncbi.nlm.nih.gov\]](#)
- [To cite this document: BenchChem. \[Experimental Guide for Using SphK2-IN-2 in Neuroscience Research\]. BenchChem, \[2026\]. \[Online PDF\]. Available at: \[https://www.benchchem.com/product/b12401688/docs#experimental-guide-for-using-sphk2-in-2-in-neuroscience-research\]](#)

Disclaimer & Data Validity:

The information provided in this document is for Research Use Only (RUO) and is strictly not intended for diagnostic or therapeutic procedures. While BenchChem strives to provide accurate protocols, we make no warranties, express or implied, regarding the fitness of this product for every specific experimental setup.

Technical Support: The protocols provided are for reference purposes. Unsure if this reagent suits your experiment?

Need Industrial/Bulk Grade? [Request Custom Synthesis Quote](#)

BenchChem

Our mission is to be the trusted global source of essential and advanced chemicals, empowering scientists and researchers to drive progress in science and industry.

Contact

Address: 3281 E Guasti Rd
Ontario, CA 91761, United States
Phone: (601) 213-4426
Email: info@benchchem.com

[Contact our Ph.D. Support Team for a compatibility check](#)