

Application Notes: Biochemical Assay Protocol for pUL89 Endonuclease-IN-2

Author: BenchChem Technical Support Team. **Date:** April 2026

Compound of Interest

Compound Name: pUL89 Endonuclease-IN-2

Cat. No.: B12400387

[Get Quote](#)

For Researchers, Scientists, and Drug Development Professionals

Introduction

Human cytomegalovirus (HCMV) is a widespread pathogen that can cause severe disease in immunocompromised individuals. The HCMV terminase complex is essential for viral replication, specifically for packaging the viral genome into capsids. A key component of this complex is the pUL89 protein, which possesses endonuclease activity in its C-terminal domain (pUL89-C). This endonuclease activity is crucial for cleaving the concatemeric viral DNA into unit-length genomes, making pUL89-C a promising target for novel antiviral therapies. **pUL89 Endonuclease-IN-2** is a potent inhibitor of this enzyme and serves as a valuable tool for studying HCMV replication and for the development of new anti-HCMV drugs.

The pUL89-C endonuclease is a metal-dependent enzyme, typically requiring divalent cations like manganese (Mn^{2+}) for its catalytic activity.[1] Its mechanism involves the cleavage of a double-stranded DNA substrate. The development of inhibitors, such as **pUL89 Endonuclease-IN-2**, has been facilitated by biochemical assays that can accurately measure the enzyme's activity. These assays are fundamental for screening compound libraries and for characterizing the potency of potential inhibitors.

Signaling Pathway and Experimental Workflow

The following diagrams illustrate the role of pUL89 in the HCMV DNA packaging process and the general workflow of a biochemical assay designed to identify and characterize its inhibitors.

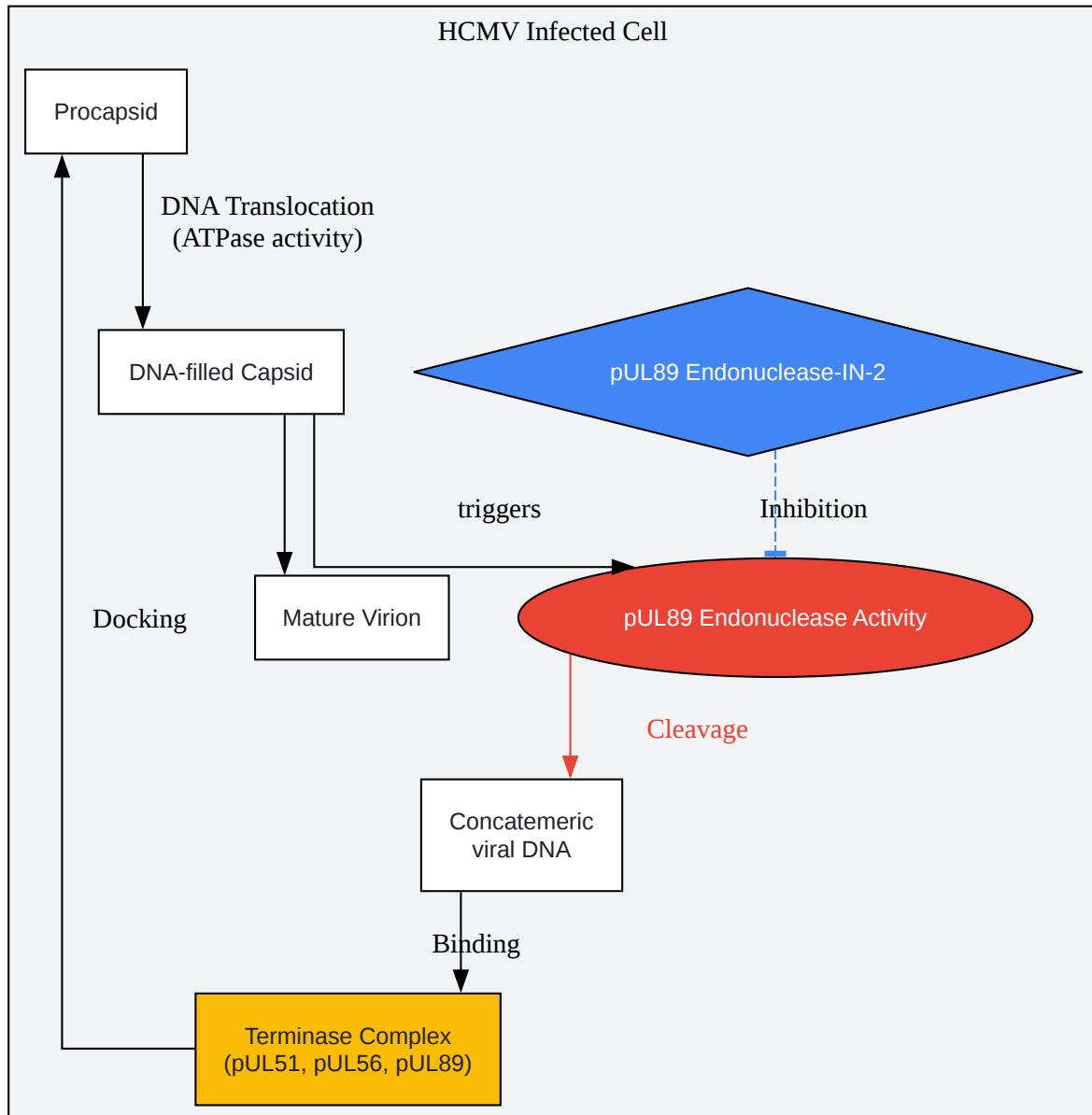

[Click to download full resolution via product page](#)

Caption: Role of pUL89 Endonuclease in HCMV Replication and Inhibition by **pUL89 Endonuclease-IN-2**.

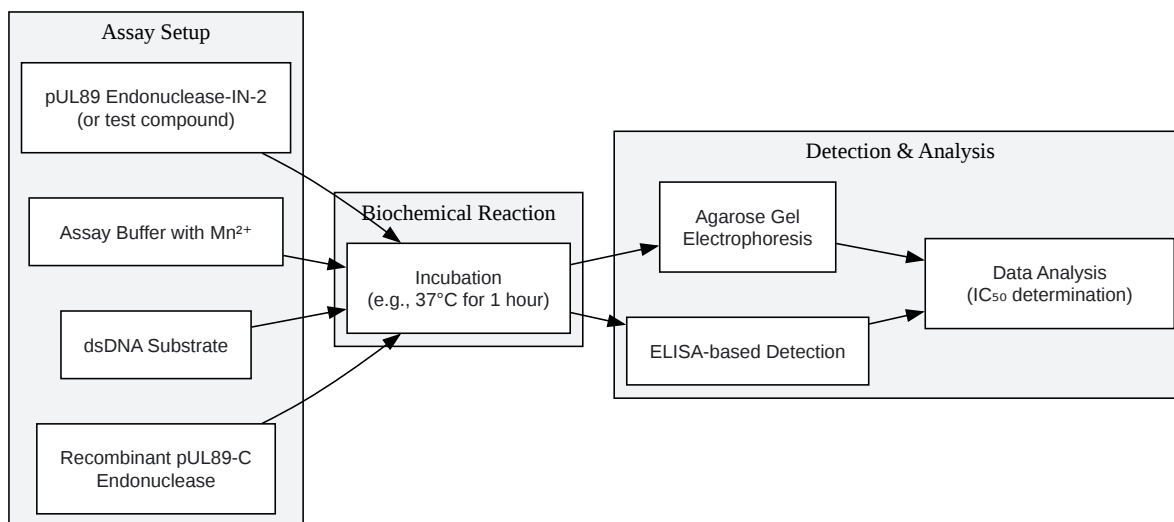

[Click to download full resolution via product page](#)

Caption: General Workflow for a pUL89 Endonuclease Biochemical Assay.

Quantitative Data Summary

The following table summarizes the inhibitory potency of **pUL89 Endonuclease-IN-2** and other related compounds against pUL89-C endonuclease. The IC₅₀ value represents the concentration of the inhibitor required to reduce the enzyme's activity by 50%.

Compound Name/Reference	Chemotype	Assay Type	IC ₅₀ (μM)
pUL89 Endonuclease-IN-2 (Compound 15k)	Not Specified	Not Specified	3.0
pUL89 Endonuclease-IN-1 (Compound 13d)	Not Specified	Not Specified	0.88[2]
Hydroxypyridonecarboxylic Acid (HPCA) - 10k	Hydroxypyridonecarboxylic Acid	ELISA	1.0[1]
Hydroxypyridonecarboxylic Acid (HPCA) - 10k	Hydroxypyridonecarboxylic Acid	Gel-based	6.0[1]
Compound 14	Hydroxypyridonecarboxylic Acid	DNA Cleavage Assay	6.0[3]
Analogs 11g, 11m, 12a	6-arylthio-3-hydroxypyrimidine-2,4-dione	ELISA	8.1, 6.2, 5.8[4]

Experimental Protocols

Two primary methods for assessing pUL89 endonuclease activity are an ELISA-based assay and a direct DNA cleavage assay analyzed by gel electrophoresis.

ELISA-Based Endonuclease Assay

This assay format is suitable for high-throughput screening of potential inhibitors.

Materials:

- Recombinant purified pUL89-C endonuclease
- Biotinylated double-stranded DNA (dsDNA) substrate
- Streptavidin-coated 96-well plates

- Assay Buffer: 50 mM Tris-HCl (pH 7.5), 100 mM NaCl, 5 mM MnCl₂, 1 mM DTT, and 0.01% (v/v) Tween-20
- Wash Buffer: PBS with 0.05% (v/v) Tween-20
- Anti-dsDNA antibody conjugated to Horseradish Peroxidase (HRP)
- TMB (3,3',5,5'-Tetramethylbenzidine) substrate
- Stop Solution (e.g., 2 N H₂SO₄)
- **pUL89 Endonuclease-IN-2** or other test compounds
- Plate reader

Protocol:

- Plate Preparation: Wash the streptavidin-coated 96-well plates three times with Wash Buffer.
- Substrate Immobilization: Add 100 µL of biotinylated dsDNA substrate (e.g., 100 ng/mL in Assay Buffer) to each well. Incubate for 1 hour at room temperature to allow the substrate to bind to the streptavidin.
- Washing: Wash the wells three times with Wash Buffer to remove any unbound substrate.
- Inhibitor Addition: Prepare serial dilutions of **pUL89 Endonuclease-IN-2** or other test compounds in Assay Buffer. Add 10 µL of each dilution to the appropriate wells. Include wells with buffer only (negative control) and wells with a known inhibitor or no inhibitor (positive control).
- Enzyme Addition and Reaction: Add 90 µL of a pre-diluted solution of pUL89-C endonuclease in Assay Buffer to each well.
- Incubation: Incubate the plate at 37°C for 1 to 2 hours.
- Washing: Wash the wells three times with Wash Buffer to remove the enzyme and cleaved DNA fragments.

- Antibody Binding: Add 100 μL of HRP-conjugated anti-dsDNA antibody diluted in a suitable blocking buffer to each well. Incubate for 1 hour at room temperature.
- Washing: Wash the wells five times with Wash Buffer.
- Detection: Add 100 μL of TMB substrate to each well and incubate in the dark for 15-30 minutes, or until sufficient color development.
- Stopping the Reaction: Add 50 μL of Stop Solution to each well.
- Data Acquisition: Measure the absorbance at 450 nm using a plate reader. The signal will be inversely proportional to the endonuclease activity.
- Data Analysis: Calculate the percent inhibition for each compound concentration and determine the IC_{50} value by fitting the data to a dose-response curve.

DNA Cleavage Assay (Agarose Gel-Based)

This method provides a direct visualization of DNA cleavage.

Materials:

- Recombinant purified pUL89-C endonuclease
- Plasmid DNA (e.g., pUC18) or a specific linear dsDNA substrate
- Assay Buffer: 50 mM Tris-HCl (pH 7.5), 100 mM NaCl, 5 mM MnCl_2 , 1 mM DTT
- **pUL89 Endonuclease-IN-2** or other test compounds
- DNA Loading Dye
- Agarose gel (1%) containing a DNA stain (e.g., ethidium bromide or SYBR Safe)
- TAE or TBE buffer for electrophoresis
- Gel imaging system

Protocol:

- Reaction Setup: In microcentrifuge tubes, prepare the reaction mixtures. For a 20 μ L reaction, combine:
 - 2 μ L of 10x Assay Buffer
 - 1 μ L of **pUL89 Endonuclease-IN-2** or test compound at various concentrations (or DMSO as a vehicle control)
 - x μ L of purified pUL89-C endonuclease
 - y μ L of DNA substrate (e.g., 500 ng of plasmid DNA)
 - Nuclease-free water to a final volume of 20 μ L
- Pre-incubation (optional): Pre-incubate the enzyme with the inhibitor for 15 minutes at room temperature before adding the DNA substrate.
- Reaction Incubation: Incubate the reaction mixtures at 37°C for 1 hour.
- Stopping the Reaction: Stop the reaction by adding 4 μ L of DNA Loading Dye containing a chelating agent like EDTA.
- Agarose Gel Electrophoresis: Load the entire reaction mixture into the wells of a 1% agarose gel. Run the gel at a constant voltage (e.g., 100 V) until the dye front has migrated an adequate distance.
- Visualization and Analysis: Visualize the DNA bands using a gel imaging system. The cleavage of a supercoiled plasmid will result in the appearance of nicked (open circular) and linear DNA forms. Quantify the intensity of the bands corresponding to the uncleaved and cleaved DNA.
- Data Analysis: Calculate the percentage of DNA cleavage for each reaction. The IC₅₀ can be determined by plotting the percentage of cleavage against the inhibitor concentration.

Need Custom Synthesis?

BenchChem offers custom synthesis for rare earth carbides and specific isotopic labeling.

Email: info@benchchem.com or [Request Quote Online](#).

References

- [1. journals.asm.org \[journals.asm.org\]](https://journals.asm.org)
- [2. medchemexpress.com \[medchemexpress.com\]](https://medchemexpress.com)
- [3. Inhibiting HCMV pUL89-C endonuclease with metal-binding compounds - PMC \[pmc.ncbi.nlm.nih.gov\]](https://pubmed.ncbi.nlm.nih.gov/31111111/)
- [4. Metal binding 6-arylthio-3-hydroxypyrimidine-2,4-diones inhibited human cytomegalovirus by targeting the pUL89 endonuclease of the terminase complex - PMC \[pmc.ncbi.nlm.nih.gov\]](https://pubmed.ncbi.nlm.nih.gov/31111112/)
- To cite this document: BenchChem. [Application Notes: Biochemical Assay Protocol for pUL89 Endonuclease-IN-2]. BenchChem, [2026]. [Online PDF]. Available at: [\[https://www.benchchem.com/product/b12400387/docs#application-notes-biochemical-assay-protocol-for-pul89-endonuclease-in-2\]](https://www.benchchem.com/product/b12400387/docs#application-notes-biochemical-assay-protocol-for-pul89-endonuclease-in-2)

Disclaimer & Data Validity:

The information provided in this document is for Research Use Only (RUO) and is strictly not intended for diagnostic or therapeutic procedures. While BenchChem strives to provide accurate protocols, we make no warranties, express or implied, regarding the fitness of this product for every specific experimental setup.

Technical Support: The protocols provided are for reference purposes. Unsure if this reagent suits your experiment?

Need Industrial/Bulk Grade? [Request Custom Synthesis Quote](#)

BenchChem

Our mission is to be the trusted global source of essential and advanced chemicals, empowering scientists and researchers to drive progress in science and industry.

Contact

Address: 3281 E Guasti Rd
Ontario, CA 91761, United States
Phone: (601) 213-4426
Email: info@benchchem.com

Contact our Ph.D. Support Team for a compatibility check