

Technical Support Center: Strategies for Efficient Civetone Synthesis

Author: BenchChem Technical Support Team. **Date:** May 2026

Compound of Interest

Compound Name:	Civetone
CAS No.:	542-46-1
Cat. No.:	B1240492

[Get Quote](#)

Welcome to the Technical Support Center for **Civetone** Synthesis. This guide is designed for researchers, scientists, and professionals in drug development and fragrance chemistry. Here, we provide in-depth troubleshooting guides, frequently asked questions (FAQs), and detailed protocols to address the common challenges encountered during the synthesis of **civetone**, a valuable macrocyclic musk. Our approach is rooted in scientific principles and practical, field-tested experience to enhance the efficiency and success of your synthetic endeavors.

Introduction to Civetone Synthesis

(Z)-**Civetone**, or (9Z)-cycloheptadec-9-en-1-one, is a 17-membered macrocyclic ketone prized for its characteristic musky odor, making it a crucial component in the fragrance industry.^[1] Historically sourced from the African civet, ethical and sustainability concerns have driven the development of numerous synthetic routes.^[1] Modern strategies often leverage powerful cyclization reactions to construct the challenging macrocyclic core. However, each approach presents a unique set of potential difficulties. This guide will navigate you through the intricacies of the most common synthetic pathways, offering solutions to overcome experimental hurdles.

Troubleshooting Guide: Key Synthetic Strategies

This section is structured in a question-and-answer format to directly address specific issues you may encounter during your experiments.

Strategy 1: Dieckmann Condensation and its Variants

The Dieckmann condensation is a classical intramolecular Claisen condensation used to form cyclic β -keto esters, which can then be decarboxylated to yield the desired macrocyclic ketone.

[1][2][3][4][5][6]

Q1: My Dieckmann condensation is resulting in very low yields or failing completely when targeting the 17-membered **civetone** ring. What are the likely causes and solutions?

A1: The classical Dieckmann condensation is generally most efficient for forming 5- and 6-membered rings.[2][4][6] Synthesizing a large ring like **civetone** (17-membered) is challenging due to several factors:

- **High Dilution Principle:** To favor intramolecular cyclization over intermolecular polymerization, reactions must be run at very high dilution. This can be impractical for larger-scale synthesis and can lead to very slow reaction rates.
- **Unfavorable Entropics:** The likelihood of the two ends of a long, flexible diester chain finding each other to react is low, leading to poor reaction kinetics.
- **Side Reactions:** At the high temperatures and long reaction times often required, side reactions such as hydrolysis of the ester or decomposition of the product can become significant. Dimerization is also a common side reaction for medium and large rings.[3]

Troubleshooting Steps:

- **Optimize Reaction Concentration:** While high dilution is necessary, it's a parameter that requires careful optimization. Start with the concentration reported in a reliable literature procedure and then systematically vary it to find the optimal balance for your specific substrate.

- **Choice of Base and Solvent:** The use of a strong, non-nucleophilic base is crucial. Sodium ethoxide in ethanol is traditional, but sterically hindered bases like potassium tert-butoxide (t-BuOK) or sodium hydride (NaH) in aprotic solvents like THF or toluene can minimize side reactions.[3] Ensure the base is fully dissolved and active.
- **Consider the Ti-Dieckmann Condensation:** A significant improvement for macrocyclization is the use of a titanium-mediated Dieckmann condensation (often referred to as a Ti-Claisen condensation). This method offers several advantages:
 - **Higher Concentrations:** Reactions can be run at significantly higher concentrations (e.g., 100–300 mM) compared to the classical approach, making it more practical for larger scales.
 - **Milder Conditions:** The reaction proceeds at lower temperatures (0–5 °C) and shorter reaction times (1–3 hours).
 - **Improved Yields:** It often provides higher yields of the desired macrocycle.
 - **Reagents:** Typically involves the use of TiCl₄ and a tertiary amine base like triethylamine (Et₃N) or tributylamine (Bu₃N).[7]

Q2: I'm observing significant amounts of a dimeric byproduct in my Dieckmann condensation. How can I minimize this?

A2: The formation of a 34-membered macrocyclic diketone is a common issue arising from the intermolecular reaction of two diester molecules.[7] This is a direct consequence of the concentration being too high.

Troubleshooting Steps:

- **Syringe Pump Addition:** A highly effective technique to maintain a pseudo-high dilution is to add the diester substrate very slowly via a syringe pump to a solution of the base. This keeps the instantaneous concentration of the unreacted diester low, favoring the intramolecular pathway.
- **Reduce Overall Concentration:** If syringe pump addition is not feasible, significantly lower the overall concentration of your reaction.

Strategy 2: Ring-Closing Metathesis (RCM)

Ring-closing metathesis, utilizing ruthenium-based catalysts like the Grubbs or Hoveyda-Grubbs catalysts, is a powerful and widely used method for synthesizing macrocycles, including **civetone**.^[8]

Q1: My RCM reaction is sluggish or stalls before completion, resulting in low yields of **civetone**. What could be the problem?

A1: Low yields in RCM reactions can often be attributed to catalyst deactivation or suboptimal reaction conditions.

Troubleshooting Steps:

- Ensure Purity of Reagents and Solvents: Ruthenium metathesis catalysts are sensitive to impurities.
 - Peroxides: Ethers like THF can form peroxides upon storage. Use freshly distilled or inhibitor-free, peroxide-tested solvents. Peroxides will oxidize and deactivate the catalyst.^[9]
 - Water and Oxygen: While many modern catalysts are air-stable as solids, they are susceptible to decomposition in solution in the presence of oxygen and water.^[9] Degas your solvent thoroughly (e.g., by sparging with argon for 30-60 minutes) and run the reaction under an inert atmosphere (argon or nitrogen).
 - Amines and Other Coordinating Groups: Impurities with strongly coordinating functional groups can bind to the ruthenium center and inhibit catalysis.^[9]
- Optimize Temperature: Higher temperatures can increase the reaction rate but also accelerate catalyst decomposition.^[10] If you suspect catalyst degradation, try running the reaction at a lower temperature for a longer period. For example, reactions at 40 °C often show less byproduct formation from catalyst decomposition than those at 60 °C.^[10]
- Catalyst Choice and Loading:

- Catalyst Generation: Second-generation Grubbs (GII) and Hoveyda-Grubbs (HGII) catalysts are generally more robust and reactive than the first-generation catalyst. For sterically hindered substrates, specialized catalysts may be required.[9]
- Catalyst Loading: Increasing the catalyst loading can sometimes push a sluggish reaction to completion. However, this can also lead to more byproducts from catalyst decomposition. Typical loadings range from 1-10 mol%.
- Removal of Ethylene: The RCM of terminal dienes produces ethylene as a byproduct.[11] To drive the equilibrium towards the product, it is beneficial to remove the ethylene from the reaction mixture. This can be achieved by gently bubbling a stream of an inert gas (e.g., argon) through the reaction solution or by performing the reaction under a slight vacuum.

Q2: My RCM reaction is producing a mixture of (E) and (Z) isomers of **civetone**. How can I improve the selectivity for the desired (Z)-isomer?

A2: Achieving high (Z)-selectivity in macrocyclic RCM can be challenging as the (E)-isomer is often thermodynamically more stable.

Troubleshooting Steps:

- Use a Z-Selective Catalyst: The most direct approach is to use a ruthenium catalyst specifically designed for Z-selective metathesis. These catalysts often feature bulky chelating ligands that favor the formation of the cis-alkene.
- Lower the Reaction Temperature: Running the reaction at lower temperatures can sometimes favor the kinetic (Z)-product over the thermodynamic (E)-product.
- Add Isomerization Suppressants: Isomerization of the initially formed (Z)-double bond to the more stable (E)-isomer can be a significant side reaction. This is often caused by ruthenium-hydride species formed from catalyst decomposition. Adding a mild acid, such as acetic acid, or a hydride scavenger like 1,4-benzoquinone can suppress this isomerization.[9] Phenol has also been used as an additive to improve RCM yields and suppress side reactions, particularly with the GII catalyst.[10]

Q3: I am observing the formation of oligomers or polymers instead of the desired macrocycle. What is causing this?

A3: The formation of linear oligomers or polymers indicates that intermolecular metathesis is outcompeting the intramolecular ring-closing reaction.

Troubleshooting Steps:

- **High Dilution:** This is the most critical factor. For macrocyclization, the reaction must be run at a very low concentration (typically 0.1-10 mM) to favor the intramolecular pathway.
- **Slow Addition:** As with the Dieckmann condensation, using a syringe pump to slowly add the diene substrate to the catalyst solution can maintain a state of pseudo-high dilution and significantly improve the yield of the macrocycle.

Strategy 3: Alkyne Metathesis Followed by Semihydrogenation

An alternative metathesis approach involves the ring-closing alkyne metathesis (RCAM) of a diyne, followed by stereoselective semihydrogenation of the resulting cycloalkyne to the (Z)-alkene of **civetone**.[\[12\]](#)

Q1: My alkyne metathesis reaction is not proceeding efficiently. What are the common issues?

A1: Alkyne metathesis often requires more forcing conditions than alkene metathesis and the catalysts can be sensitive.

Troubleshooting Steps:

- **Catalyst Choice:** Schrock's tungsten alkylidyne complexes or in situ generated molybdenum catalysts (e.g., from $\text{Mo}(\text{CO})_6$ and a phenol) are commonly used.[\[12\]](#) These catalysts can be sensitive to air and moisture, so rigorous inert atmosphere techniques are essential.
- **Temperature and Reaction Time:** These reactions often require elevated temperatures. Optimization of both temperature and reaction time is crucial to drive the reaction to completion without decomposing the product.
- **Removal of Volatile Alkyne Byproduct:** The reaction is an equilibrium process. Removing the volatile alkyne byproduct (e.g., 2-butyne if using a catalyst derived from it) by vacuum or by purging with an inert gas can drive the reaction towards the desired macrocycle.[\[13\]](#)

Q2: My Lindlar hydrogenation of the cycloalkyne is over-reducing to the alkane or is very slow. How can I improve this step?

A2: The Lindlar catalyst (palladium on calcium carbonate poisoned with lead) is designed for the stereoselective semihydrogenation of alkynes to cis-alkenes.^[14] Its activity can be variable.

Troubleshooting Steps:

- **Catalyst Quality and Activity:** The activity of Lindlar's catalyst can vary between batches. It is advisable to test a new batch on a small scale first. If the catalyst is too active, it can lead to over-reduction. If it is not active enough, the reaction will be slow or stall.
- **Catalyst Poisoning:** The selectivity of the Lindlar catalyst relies on it being "poisoned". Quinoline is often added as an additional poison to further temper the catalyst's activity and prevent over-reduction.^[14] The amount of quinoline may need to be optimized.
- **Hydrogen Pressure:** Use a balloon of hydrogen or a low, constant pressure of H₂. High pressures will favor over-reduction to the alkane.
- **Monitor the Reaction Carefully:** Follow the progress of the reaction closely by TLC or GC-MS to stop it as soon as the starting material is consumed to prevent over-reduction of the desired alkene.

Frequently Asked Questions (FAQs)

Q: What are the main advantages of synthesizing **civetone** from oleic acid?

A: Oleic acid is an inexpensive and readily available renewable feedstock.^[8] Syntheses from oleic acid often begin with a self-metathesis reaction to produce a C18-dioic acid derivative, which is a direct precursor for the 17-membered **civetone** ring.^[8] This makes it a very cost-effective and sustainable starting point for large-scale production.

Q: I am performing a self-metathesis of oleic acid methyl ester. What are the expected products and how can I purify the desired precursor for **civetone**?

A: The self-metathesis of methyl oleate will produce a mixture of three main products: the desired dimethyl 9-octadecene-1,18-dioate, 9-octadecene, and unreacted methyl oleate. The

desired di-ester can be separated from the more volatile olefin and the starting material by distillation or chromatography. In some procedures using oleic acid, the resulting dicarboxylic acid precipitates from the reaction mixture, simplifying its isolation.[8]

Q: How can I effectively purify the final **civetone** product?

A: Purification of **civetone** can be achieved by several methods depending on the scale and the nature of the impurities.

- Column Chromatography: Silica gel chromatography is a reliable method for purifying **civetone** on a laboratory scale.[7]
- Distillation: Given its relatively high boiling point, vacuum distillation can be an effective method for purification, especially on a larger scale.
- Crystallization: **Civetone** is a low-melting solid, and crystallization from a suitable solvent can be an excellent final purification step.

Q: What are the safety precautions I should take when working with the reagents for **civetone** synthesis?

A: Standard laboratory safety practices should always be followed. Specific hazards include:

- Organometallic Catalysts: Many metathesis catalysts are air and moisture sensitive and can be pyrophoric. They should be handled under an inert atmosphere.
- Strong Bases: Reagents like sodium hydride and potassium tert-butoxide are highly reactive and corrosive. They react violently with water.
- Solvents: Many organic solvents are flammable and have associated health risks. Always work in a well-ventilated fume hood.
- Titanium Tetrachloride (TiCl₄): This is a corrosive liquid that reacts vigorously with water, releasing HCl gas. It should be handled with extreme care in a fume hood.

Experimental Protocols and Data

Comparative Data for Civetone Synthesis Strategies

Strategy	Key Reaction	Typical Catalyst/Reagent	Catalyst Loading	Temperature (°C)	Reaction Time (h)	Typical Yield (%)	Key Advantages	Key Disadvantages
Classic Dieckmann	Intramolecular Condensation	NaH or t-BuOK	Stoichiometric	Reflux	12-48	< 30%	Inexpensive reagents	Low yield for large rings, high dilution
Ti-Dieckmann	Intramolecular Condensation	TiCl ₄ / Et ₃ N	> 1 equivalent	0-5	1-3	60-80%	Higher concentration, milder conditions, better yield	Stoichiometric use of TiCl ₄
Alkene RCM	Ring-Closing Metathesis	Grubbs II or Hoveyda-Grubbs II	1-10 mol%	25-60	4-24	50-85%	High functional group tolerance, reliable	Catalyst cost, high dilution, E/Z control
Alkyne RCM + Hydrogenation	Ring-Closing Metathesis & Hydrogenation	Schrock or Mo-based catalyst ; Lindlar's catalyst	5-10 mol%	80-120	6-18	60-75% (over 2 steps)	Excellent (Z)-selectivity	Harsh conditions for metathesis, catalyst sensitivity

Detailed Experimental Workflow: Ti-Dieckmann Condensation for Civetone Synthesis

This protocol is a generalized procedure based on literature reports for the synthesis of the β -keto ester precursor to **civetone**.

- **Preparation:** Under an inert atmosphere of argon, add anhydrous dichloromethane (DCM) to a flame-dried, three-neck round-bottom flask equipped with a magnetic stirrer, a thermometer, and a dropping funnel.
- **Reagent Addition:** Cool the DCM to 0 °C in an ice bath. Slowly add titanium tetrachloride (TiCl₄, e.g., 2.2 equivalents) to the stirred solvent. Then, add a tertiary amine base such as triethylamine (Et₃N, e.g., 2.5 equivalents).
- **Substrate Addition:** In a separate flask, dissolve the precursor diester (e.g., dimethyl (Z)-9-octadecenedioate, 1.0 equivalent) in anhydrous DCM. Transfer this solution to the dropping funnel and add it dropwise to the reaction mixture over 1-2 hours, maintaining the internal temperature below 5 °C.
- **Reaction Monitoring:** Stir the reaction mixture at 0-5 °C. Monitor the progress of the reaction by Thin Layer Chromatography (TLC) or Gas Chromatography-Mass Spectrometry (GC-MS). The reaction is typically complete within 1-3 hours.
- **Workup:** Upon completion, carefully quench the reaction by slowly adding a saturated aqueous solution of ammonium chloride (NH₄Cl). Separate the organic layer. Extract the aqueous layer with DCM (2-3 times). Combine the organic layers, wash with brine, dry over anhydrous sodium sulfate (Na₂SO₄), filter, and concentrate under reduced pressure.
- **Purification:** The crude β -keto ester can be purified by silica gel column chromatography.
- **Decarboxylation:** The purified β -keto ester is then subjected to decarboxylation (e.g., by heating in the presence of an acid or base) to yield (Z)-**civetone**.

Visualizing the Workflows

Decision Tree for Troubleshooting Low RCM Yields

This diagram illustrates a logical approach to diagnosing and solving common issues leading to low yields in ring-closing metathesis reactions.



[Click to download full resolution via product page](#)

Caption: Troubleshooting flowchart for low-yield RCM reactions.

General Workflow for Civetone Synthesis from Oleic Acid

This diagram outlines the key transformations in a common synthetic route to **civetone** starting from oleic acid.

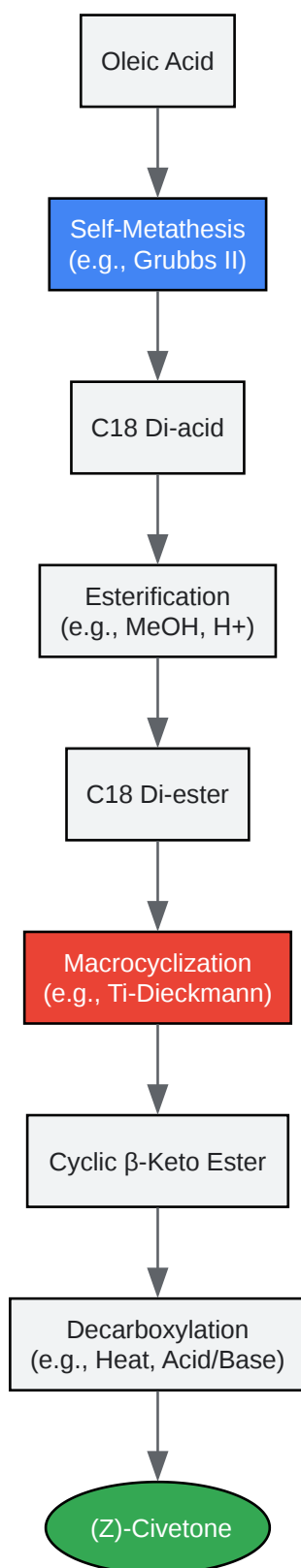

[Click to download full resolution via product page](#)

Caption: Synthetic pathway from oleic acid to **civetone**.

References

- Hagiwara, H., Adachi, T., Nakamura, T., Hoshi, T., & Suzuki, T. (2012). Revisit to (Z)-**Civetone** Synthesis. *Natural Product Communications*, 7(7), 1934578X1200700. [[Link](#)]
- Fürstner, A., & Seidel, G. (2000). Ring closing alkyne metathesis: stereoselective synthesis of **civetone**. *Journal of Organometallic Chemistry*, 606(1), 75-78. [[Link](#)]
- Schmalz, J. (2020). Claisen Condensation and Dieckmann Condensation. *Master Organic Chemistry*. [[Link](#)]
- Tanabe, Y., Makita, A., Funakoshi, S., Hamasaki, R., & Kawakusu, T. (2002). Practical Synthesis of (Z)**Civetone** Utilizing Ti-Dieckmann Condensation. *Advanced Synthesis & Catalysis*, 344(5), 507-510. [[Link](#)]
- Lathrop, S. P., & Haskell-Luevano, C. (2020). Optimized Ring Closing Metathesis Reaction Conditions to Suppress Desallyl Side Products in the Solid Phase Synthesis of Cyclic Peptides involving Tyrosine(O-allyl). *National Institutes of Health*. [[Link](#)]
- Wikipedia. (2023). **Civetone**. In Wikipedia. [[Link](#)]
- The Organic Chemistry Tutor. (2018). Dieckmann Condensation Reaction Mechanism [Video]. YouTube. [[Link](#)]
- Chemistry LibreTexts. (2023). Dieckmann Condensation. [[Link](#)]
- Professor Dave Explains. (2018). Claisen Condensation and Dieckmann Condensation [Video]. YouTube. [[Link](#)]
- Organic Chemistry Portal. (n.d.). Dieckmann Condensation. Retrieved January 22, 2026, from [[Link](#)]
- Chemistry Steps. (n.d.). Dieckmann condensation – An Intramolecular Claisen Reaction. Retrieved January 22, 2026, from [[Link](#)]
- Google Patents. (n.d.). WO2014018578A1 - Methods of converting mixtures of palmitoleic and oleic acid esters to high value products.

- Wikipedia. (2023). Ring-closing metathesis. In Wikipedia. [\[Link\]](#)
- University of Windsor. (n.d.). Alkyne metathesis. Scholar. [\[Link\]](#)
- Organic Reactions. (2020). Alkyne Metathesis. Wiley. [\[Link\]](#)
- UCL Discovery. (2020). Continuous Flow Z-stereoselective Olefin Metathesis: Development and Applications in the Synthesis of Pheromones and Macrocycl. [\[Link\]](#)
- Organic Syntheses. (n.d.). Palladium Catalyst for Partial Reduction of Acetylenes (Lindlar's Catalyst). Organic Syntheses. [\[Link\]](#)
- Schmalz, J. (2011). Partial Reduction of Alkynes With Lindlar's Catalyst. Master Organic Chemistry. [\[Link\]](#)
- L.S.College, Muzaffarpur. (2020). Lindlar catalyst. [\[Link\]](#)
- Reddit. (2023). Grubbs G2 metathesis catalyst synthesis troubleshooting. r/Chempros. [\[Link\]](#)
- Reddit. (2023). RCM Troubleshooting. r/Chempros. [\[Link\]](#)
- Google Patents. (n.d.). US3235601A - Process for the production of **civetone** and homologues.
- YouTube. (2021). Oleic Acid Purification. [\[Link\]](#)
- Hilaris Publisher. (2020). Isolation, Characterization and Quantification of **Civetone** from Civet Musk. [\[Link\]](#)
- Macmillan Group. (n.d.). Deactivation Pathways in Transition Metal Catalysis. Princeton University. [\[Link\]](#)
- Journal of the American Chemical Society. (2017). Loss and Reformation of Ruthenium Alkylidene: Connecting Olefin Metathesis, Catalyst Deactivation, Regeneration, and Isomerization. [\[Link\]](#)
- ScienceDaily. (2017). Chemists report E-selective macrocyclic ring-closing metathesis. [\[Link\]](#)

- PubMed Central (PMC). (2013). Kinetically E-Selective Macrocyclic Ring-Closing Metathesis. [\[Link\]](#)

Need Custom Synthesis?

BenchChem offers custom synthesis for rare earth carbides and specific isotopic labeling.

Email: info@benchchem.com or [Request Quote Online](#).

Sources

- [1. Dieckmann Condensation - Chemistry Steps \[chemistrysteps.com\]](#)
- [2. masterorganicchemistry.com \[masterorganicchemistry.com\]](#)
- [3. alfa-chemistry.com \[alfa-chemistry.com\]](#)
- [4. chem.libretexts.org \[chem.libretexts.org\]](#)
- [5. youtube.com \[youtube.com\]](#)
- [6. Dieckmann Condensation \[organic-chemistry.org\]](#)
- [7. WO2014018578A1 - Methods of converting mixtures of palmitoleic and oleic acid esters to high value products - Google Patents \[patents.google.com\]](#)
- [8. researchgate.net \[researchgate.net\]](#)
- [9. React App \[pmc.unicore.com\]](#)
- [10. Optimized Ring Closing Metathesis Reaction Conditions to Suppress Desallyl Side Products in the Solid Phase Synthesis of Cyclic Peptides involving Tyrosine\(O-allyl\) - PMC \[pmc.ncbi.nlm.nih.gov\]](#)
- [11. Ring-closing metathesis - Wikipedia \[en.wikipedia.org\]](#)
- [12. researchgate.net \[researchgate.net\]](#)
- [13. uwindsor.ca \[uwindsor.ca\]](#)
- [14. Iscollege.ac.in \[Iscollege.ac.in\]](#)
- To cite this document: BenchChem. [Technical Support Center: Strategies for Efficient Civetone Synthesis]. BenchChem, [2026]. [Online PDF]. Available at: [\[https://www.benchchem.com/product/b1240492/docs#technical-support-center-strategies-for-efficient-civetone-synthesis\]](https://www.benchchem.com/product/b1240492/docs#technical-support-center-strategies-for-efficient-civetone-synthesis)

Disclaimer & Data Validity:

The information provided in this document is for Research Use Only (RUO) and is strictly not intended for diagnostic or therapeutic procedures. While BenchChem strives to provide accurate protocols, we make no warranties, express or implied, regarding the fitness of this product for every specific experimental setup.

Technical Support: The protocols provided are for reference purposes. Unsure if this reagent suits your experiment?

Need Industrial/Bulk Grade? [Request Custom Synthesis Quote](#)

BenchChem

Our mission is to be the trusted global source of essential and advanced chemicals, empowering scientists and researchers to drive progress in science and industry.

Contact

Address: 3281 E Guasti Rd
Ontario, CA 91761, United States
Phone: (601) 213-4426
Email: info@benchchem.com

[Contact our Ph.D. Support Team for a compatibility check](#)