

Technical Support Center: 5-trans U-44069 Stability & Impact Guide

Author: BenchChem Technical Support Team. **Date:** May 2026

Compound of Interest

Compound Name: 5-trans U-44069

Cat. No.: B1240460

[Get Quote](#)

Topic: **5-trans U-44069** Degradation Products and Their Impact Document ID: TS-U44069-05T
Last Updated: 2026-02-02 Audience: Senior Researchers, Assay Developers, DMPK Scientists

Executive Summary: The Molecule & The Problem

5-trans U-44069 is a geometric isomer of the standard Thromboxane A2 (TxA2) receptor agonist, U-44069. While often used as a specific pharmacological tool to probe receptor stereoselectivity or inhibit Prostaglandin E2 (PGE2) synthase, it is also a common degradation impurity found in aged or improperly stored U-44069 stocks.

Understanding the stability profile of this lipid mediator is critical because:

- **Potency Shift:** It exhibits distinct binding kinetics compared to the cis (5Z) parent isomer.
- **Off-Target Effects:** Unlike U-44069, the 5-trans isomer is a documented inhibitor of PGE2 Synthase, potentially confounding inflammatory pathway studies.
- **Solubility Issues:** Lipid mediators are hydrophobic and prone to precipitation ("crashing out") in aqueous buffers, often mistaken for degradation.

This guide provides the technical framework to troubleshoot stability issues, identify degradation products, and mitigate experimental variability.

Stability & Degradation Dynamics

Q: What are the primary degradation pathways for 5-trans U-44069?

A: Like most prostaglandin analogs, **5-trans U-44069** is chemically fragile. The primary degradation routes are:

- **C-15 Epimerization:** The hydroxyl group at carbon 15 is susceptible to epimerization (inversion of stereochemistry) under acidic conditions or prolonged storage, leading to the formation of 15-epi-**5-trans U-44069**. This epimer typically has significantly reduced biological activity.
- **Oxidative Degradation:** The alkene double bonds (at C5 and C13) are targets for reactive oxygen species (ROS), leading to chain cleavage or the formation of polar epoxide byproducts.
- **Isomerization (Reverse):** While 5-trans is thermodynamically more stable than the 5-cis form in some contexts, exposure to UV light or radical initiators can cause geometric isomerization between the cis (Z) and trans (E) forms.

Degradation Pathway Visualization

The following diagram illustrates the structural relationship and degradation logic.

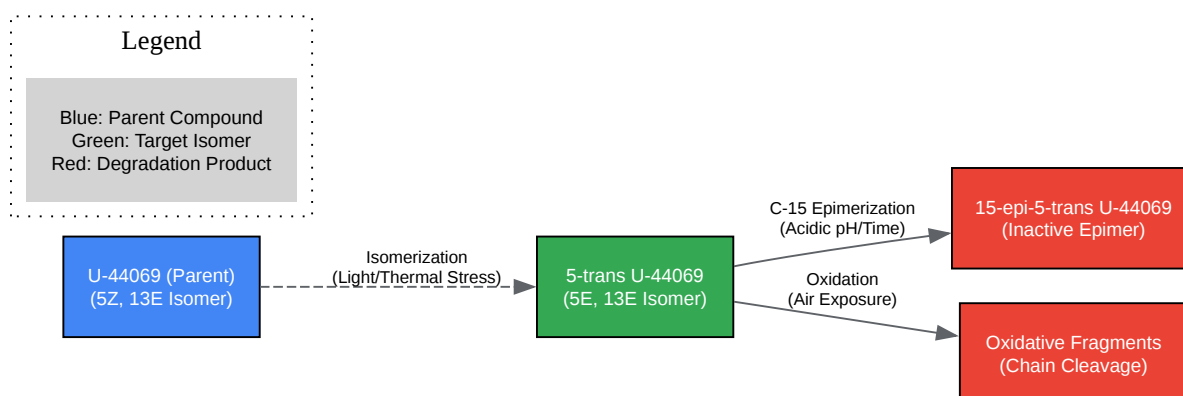

[Click to download full resolution via product page](#)

Figure 1: Chemical stability and degradation pathways of U-44069 analogs. Isomerization and epimerization are the dominant non-enzymatic breakdown mechanisms.

Biological Impact of Degradation

Q: How does the presence of degradation products affect my data?

A: Using degraded **5-trans U-44069** introduces two types of error: False Negatives (loss of potency) and False Positives (off-target inhibition).

Degradation Product / State	Biological Impact	Experimental Consequence
5-trans U-44069 (Intact)	TP Receptor Agonist; PGE2 Synthase Inhibitor	Expected pharmacological activity.
15-epi-5-trans U-44069	drastically reduced affinity for TP receptor.	Right-shift in EC50 curves. Higher concentrations required for same effect.
Oxidative Byproducts	Non-specific cytotoxicity or inactivity.	Increased background noise; potential cell viability issues in long-term assays.
Precipitated Compound	Loss of effective concentration.	High variability between replicates; "spiky" data in plate-based assays.

Critical Insight: If you are studying TP receptor kinetics and your U-44069 standard has isomerized to **5-trans U-44069**, you may observe inhibition of PGE2 biosynthesis in your system, which is not a property of the parent U-44069. This can lead to erroneous conclusions about the role of TP receptors in inflammatory feedback loops.

Troubleshooting & Handling Protocols

Workflow: Diagnosing Assay Variability

Use this decision tree if you suspect compound degradation is affecting your results.

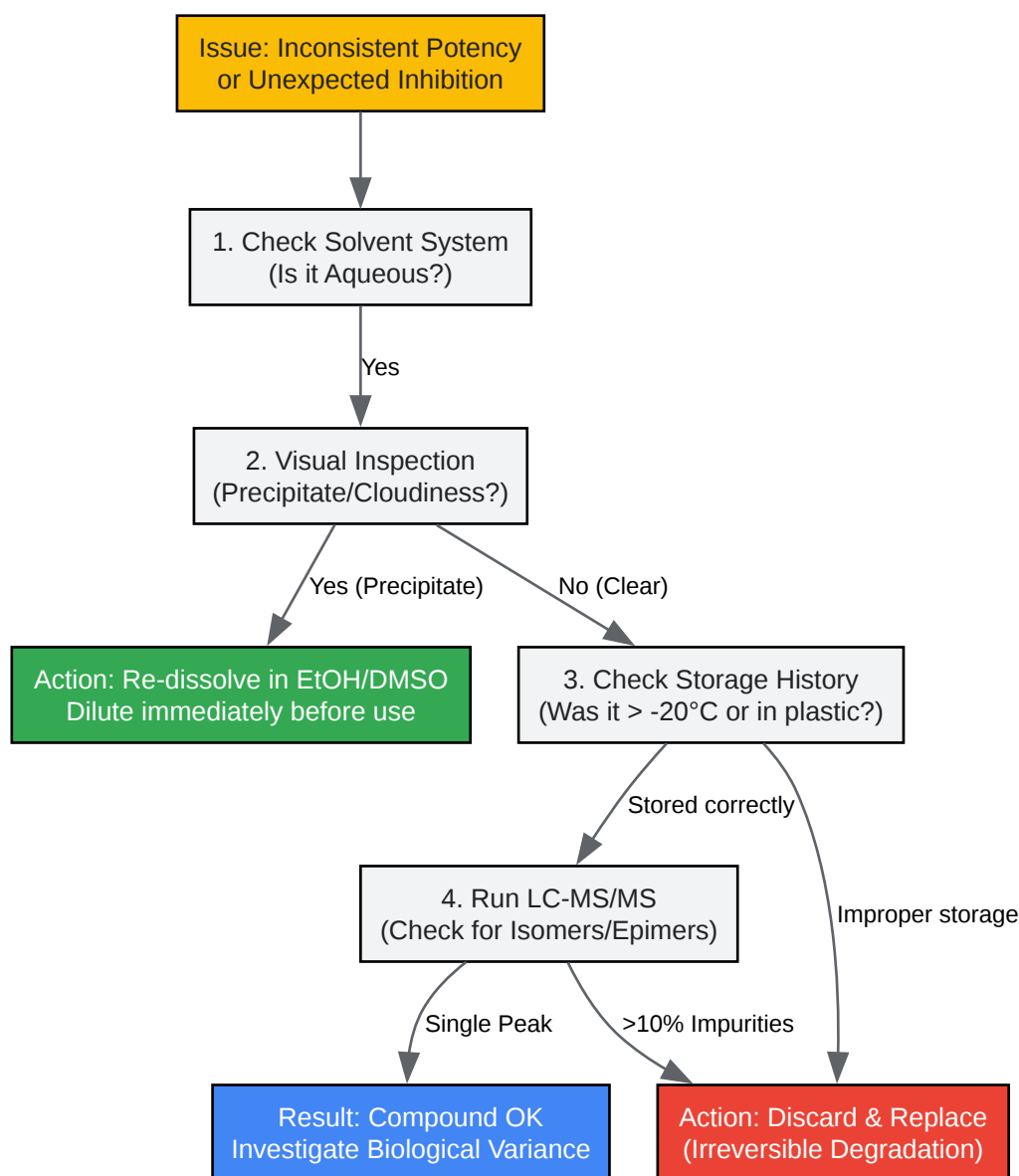

[Click to download full resolution via product page](#)

Figure 2: Troubleshooting logic for U-44069 experimental variability. Prioritize solubility checks before assuming chemical degradation.

Standard Operating Procedures (SOPs)

Protocol A: Proper Storage & Reconstitution

- The "Golden Rule": Never store **5-trans U-44069** in aqueous solution.
- Stock Solution: Dissolve in Methyl Acetate or Ethanol (purged with Argon) at concentrations >1 mg/mL. Store at -20°C or lower.

- Usage:
 - Evaporate the organic solvent using a gentle stream of Nitrogen gas (avoid oxygen).
 - Immediately reconstitute in the assay buffer (PBS, Tyrode's).
 - Use within 4 hours. Prostaglandin analogs degrade rapidly in aqueous buffers at pH > 7.4.

Protocol B: LC-MS Identification of Impurities

To confirm the purity of your **5-trans U-44069**, use the following parameters. Note that standard C18 columns may struggle to separate the cis and trans isomers; a chiral column or specialized gradient is often required.

- System: UHPLC coupled to Triple Quadrupole MS.
- Column: Waters BEH C18 (1.7 μm) or Chiralpak AD-H (for strict isomer separation).
- Mobile Phase:
 - A: Water + 0.1% Formic Acid
 - B: Acetonitrile + 0.1% Formic Acid
- Transition (MRM):
 - Precursor: m/z 351 [M+H]⁺ (or 349 [M-H]⁻ depending on ionization mode).
 - Look for "shoulder" peaks or split peaks indicating isomerization.

Frequently Asked Questions (FAQ)

Q1: Can I use DMSO instead of Ethanol for stock solutions? A: Yes, DMSO is an acceptable solvent and often preferred for cell-based assays due to lower volatility. However, ensure the DMSO is anhydrous. Water accumulation in DMSO stocks will accelerate hydrolysis and epimerization.

Q2: I see a "double peak" in my HPLC trace. Is my compound ruined? A: Likely, yes. A double peak usually indicates isomerization (cis/trans mixture) or epimerization (C-15). If the peaks are

of similar size, the reagent is significantly compromised and should be discarded, as the biological activity will be an average of the two species.

Q3: Why does **5-trans U-44069** inhibit PGE2 synthase? A: The 5-trans geometry alters the molecule's fit within the enzymatic pocket of PGE2 synthase. While U-44069 (cis) mimics the transition state of PGH2 for the TP receptor, the trans isomer appears to bind the synthase enzyme in a way that blocks substrate access, a feature distinct from the parent molecule [1].

References

- Maxey, K. M., & Bundy, G. L. (1975). The synthesis of 5-trans-prostaglandins. Tetrahedron Letters. (Foundational chemistry on trans-isomer synthesis and stability).
- Jones, R. L., et al. (1982). Characterization of a thromboxane receptor in human platelets. British Journal of Pharmacology. (Establishes U-44069 as a stable mimetic, though noting limits of stability).
- To cite this document: BenchChem. [Technical Support Center: 5-trans U-44069 Stability & Impact Guide]. BenchChem, [2026]. [Online PDF]. Available at: [\[https://www.benchchem.com/product/b1240460/docs#technical-support-center-5-trans-u-44069-stability-impact-guide\]](https://www.benchchem.com/product/b1240460/docs#technical-support-center-5-trans-u-44069-stability-impact-guide)

Disclaimer & Data Validity:

The information provided in this document is for Research Use Only (RUO) and is strictly not intended for diagnostic or therapeutic procedures. While BenchChem strives to provide accurate protocols, we make no warranties, express or implied, regarding the fitness of this product for every specific experimental setup.

Technical Support: The protocols provided are for reference purposes. Unsure if this reagent suits your experiment?

Need Industrial/Bulk Grade? [Request Custom Synthesis Quote](#)

BenchChem

Our mission is to be the trusted global source of essential and advanced chemicals, empowering scientists and researchers to drive progress in science and industry.

Contact

Address: 3281 E Guasti Rd

Ontario, CA 91761, United States

Phone: (601) 213-4426

Email: info@benchchem.com

[Contact our Ph.D. Support Team for a compatibility check](#)