

Application Notes and Protocols for Antifungal Susceptibility Testing of Ambigol A

Author: BenchChem Technical Support Team. **Date:** April 2026

Compound of Interest

Compound Name:	Ambigol A
CAS No.:	151487-20-6
Cat. No.:	B124824

[Get Quote](#)

For Researchers, Scientists, and Drug Development Professionals

Introduction

Ambigol A is a polychlorinated aromatic natural product isolated from the cyanobacterium *Fischerella ambigua*.^{[1][2]} Preliminary studies have indicated that **Ambigol A** and its derivatives possess a range of biological activities, including antibacterial and potential antifungal properties.^[1] As with many natural products, its lipophilic nature presents unique challenges in designing and executing in vitro antifungal susceptibility testing (AFST). These application notes provide detailed protocols for determining the antifungal activity of **Ambigol A**, primarily focusing on the broth microdilution and disk diffusion methods, which are standard approaches for evaluating antifungal agents.^{[1][3]}

Due to the limited publicly available data on the specific antifungal spectrum of **Ambigol A**, the provided tables are templates for researchers to populate with their experimental data. Furthermore, the precise mechanism of antifungal action for **Ambigol A** has not been fully elucidated. Based on the known effects of other cyanobacterial secondary metabolites and

polychlorinated compounds on fungal cells, a putative mechanism of action is proposed and illustrated.

Data Presentation

Table 1: Minimum Inhibitory Concentration (MIC) of Ambigol A against Various Fungal Species

The following table should be used to record the Minimum Inhibitory Concentration (MIC) values of **Ambigol A**, which is defined as the lowest concentration of the compound that completely inhibits visible growth of a microorganism.[4] It is recommended to test **Ambigol A** against a panel of clinically relevant fungal species.

Fungal Species	Strain ID	Ambigol A MIC (µg/mL)	Positive Control MIC (µg/mL) [e.g., Fluconazole, Amphotericin B]
Candida albicans	ATCC 90028	User-defined	User-defined
Candida glabrata	ATCC 90030	User-defined	User-defined
Candida parapsilosis	ATCC 22019	User-defined	User-defined
Cryptococcus neoformans	ATCC 90112	User-defined	User-defined
Aspergillus fumigatus	ATCC 204305	User-defined	User-defined
Aspergillus flavus	ATCC 204304	User-defined	User-defined
Trichophyton rubrum	ATCC 28188	User-defined	User-defined
Other (Specify)	User-defined	User-defined	

Note: Values are to be determined experimentally.

Table 2: Zone of Inhibition Diameters for Ambigol A

This table is designed to document the diameter of the zone of inhibition produced by **Ambigol A** in a disk diffusion assay. The zone of inhibition is a clear area around the antibiotic disk

where microbial growth is inhibited.

Fungal Species	Strain ID	Ambigol A Disk Content (µg)	Zone of Inhibition (mm)	Positive Control Zone of Inhibition (mm) [e.g., Fluconazole, Voriconazole]
Candida albicans	ATCC 90028	User-defined	User-defined	User-defined
Candida glabrata	ATCC 90030	User-defined	User-defined	User-defined
Candida parapsilosis	ATCC 22019	User-defined	User-defined	User-defined
Cryptococcus neoformans	ATCC 90112	User-defined	User-defined	User-defined
Aspergillus fumigatus	ATCC 204305	User-defined	User-defined	User-defined
Aspergillus flavus	ATCC 204304	User-defined	User-defined	User-defined
Trichophyton rubrum	ATCC 28188	User-defined	User-defined	User-defined
Other (Specify)	User-defined	User-defined	User-defined	

Note: Values are to be determined experimentally.

Experimental Protocols

Protocol 1: Broth Microdilution Susceptibility Testing for Ambigol A

This protocol is adapted from the Clinical and Laboratory Standards Institute (CLSI) M27-A3 guidelines for yeasts and M38-A2 for filamentous fungi, with modifications to accommodate the lipophilic nature of **Ambigol A**.^{[5][6]}

1. Preparation of **Ambigol A** Stock Solution:

- Due to its low aqueous solubility, dissolve **Ambigol A** in 100% dimethyl sulfoxide (DMSO) to create a high-concentration stock solution (e.g., 10 mg/mL).
- Further dilutions should be made in a manner that the final concentration of DMSO in the assay does not exceed 1% (v/v), as higher concentrations can inhibit fungal growth.

2. Fungal Inoculum Preparation:

- Yeasts (*Candida* spp., *Cryptococcus* spp.):
 - Culture the yeast on Sabouraud Dextrose Agar (SDA) at 35°C for 24-48 hours.
 - Suspend several colonies in sterile saline (0.85% NaCl).
 - Adjust the turbidity of the suspension to a 0.5 McFarland standard (approximately $1-5 \times 10^6$ CFU/mL).
 - Dilute this suspension in RPMI-1640 medium (with L-glutamine, without bicarbonate, buffered with MOPS) to achieve a final inoculum concentration of $0.5-2.5 \times 10^3$ CFU/mL in the microplate wells.
- Filamentous Fungi (*Aspergillus* spp., *Trichophyton* spp.):
 - Grow the mold on Potato Dextrose Agar (PDA) at 28-35°C for 5-7 days until sporulation is evident.
 - Harvest conidia by flooding the plate with sterile saline containing 0.05% Tween 80 and gently scraping the surface.
 - Transfer the suspension to a sterile tube and allow heavy particles to settle.
 - Adjust the conidial suspension to a concentration of $0.4-5 \times 10^4$ CFU/mL in RPMI-1640 medium.

3. Assay Procedure:

- In a 96-well microtiter plate, perform serial two-fold dilutions of the **Ambigol A** stock solution in RPMI-1640 medium to achieve the desired final concentration range (e.g., 0.125 - 64 µg/mL).
- Add the prepared fungal inoculum to each well.
- Include a positive control (a known antifungal agent like fluconazole or amphotericin B), a negative control (medium only), and a solvent control (medium with the highest concentration of DMSO used).
- Incubate the plates at 35°C for 24-48 hours for yeasts and 48-72 hours for filamentous fungi.

4. Determination of MIC:

- The MIC is the lowest concentration of **Ambigol A** at which there is a significant inhibition of fungal growth (typically ≥50% reduction in turbidity) compared to the growth control. This can be determined visually or by using a microplate reader at 530 nm.

Protocol 2: Disk Diffusion Susceptibility Testing for Ambigol A

The disk diffusion method provides a qualitative or semi-quantitative measure of antifungal activity.

1. Preparation of **Ambigol A** Disks:

- Prepare a stock solution of **Ambigol A** in a volatile solvent like acetone or methanol.
- Apply a known amount of the **Ambigol A** solution onto sterile paper disks (6 mm diameter) and allow the solvent to evaporate completely. A range of disk concentrations should be prepared.

2. Fungal Inoculum and Plate Preparation:

- Prepare a fungal inoculum as described in the broth microdilution protocol (adjusted to a 0.5 McFarland standard for yeasts or a specific conidial concentration for molds).

- Uniformly streak the fungal suspension onto the surface of a Mueller-Hinton Agar (MHA) plate supplemented with 2% glucose and 0.5 µg/mL methylene blue for yeasts, or on a standard MHA plate for molds.

3. Assay Procedure:

- Aseptically place the prepared **Ambigol A** disks onto the inoculated agar surface.
- Place a positive control disk (e.g., fluconazole, voriconazole) and a blank disk (with solvent only) on the plate.
- Invert the plates and incubate at 35°C for 24-48 hours for yeasts and 48-96 hours for molds, or until sufficient growth is observed.

4. Measurement of Zone of Inhibition:

- Measure the diameter of the zone of complete growth inhibition around each disk in millimeters.

Visualizations

Putative Mechanism of Action of Ambigol A

The proposed mechanism of action for **Ambigol A** against fungal cells is based on the known activities of other cyanobacterial metabolites and polychlorinated aromatic compounds. It is hypothesized that **Ambigol A** primarily targets the fungal cell membrane and cell wall, leading to a loss of integrity and subsequent cell death. This is a putative pathway and requires experimental validation.

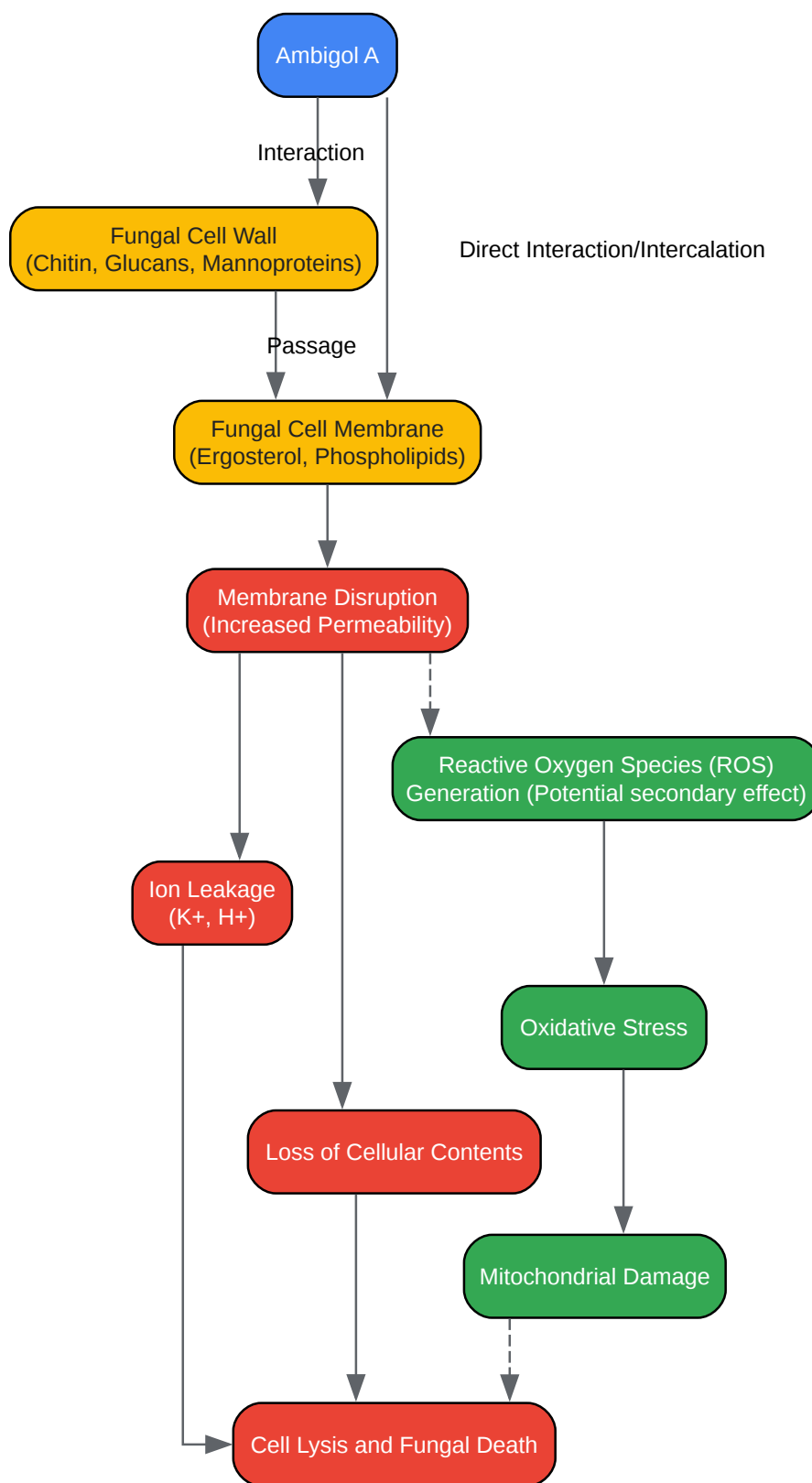

[Click to download full resolution via product page](#)

Caption: Putative mechanism of **Ambigol A**'s antifungal action.

Experimental Workflow for Antifungal Susceptibility Testing

The following diagram illustrates the general workflow for determining the antifungal susceptibility of **Ambigol A** using the broth microdilution method.

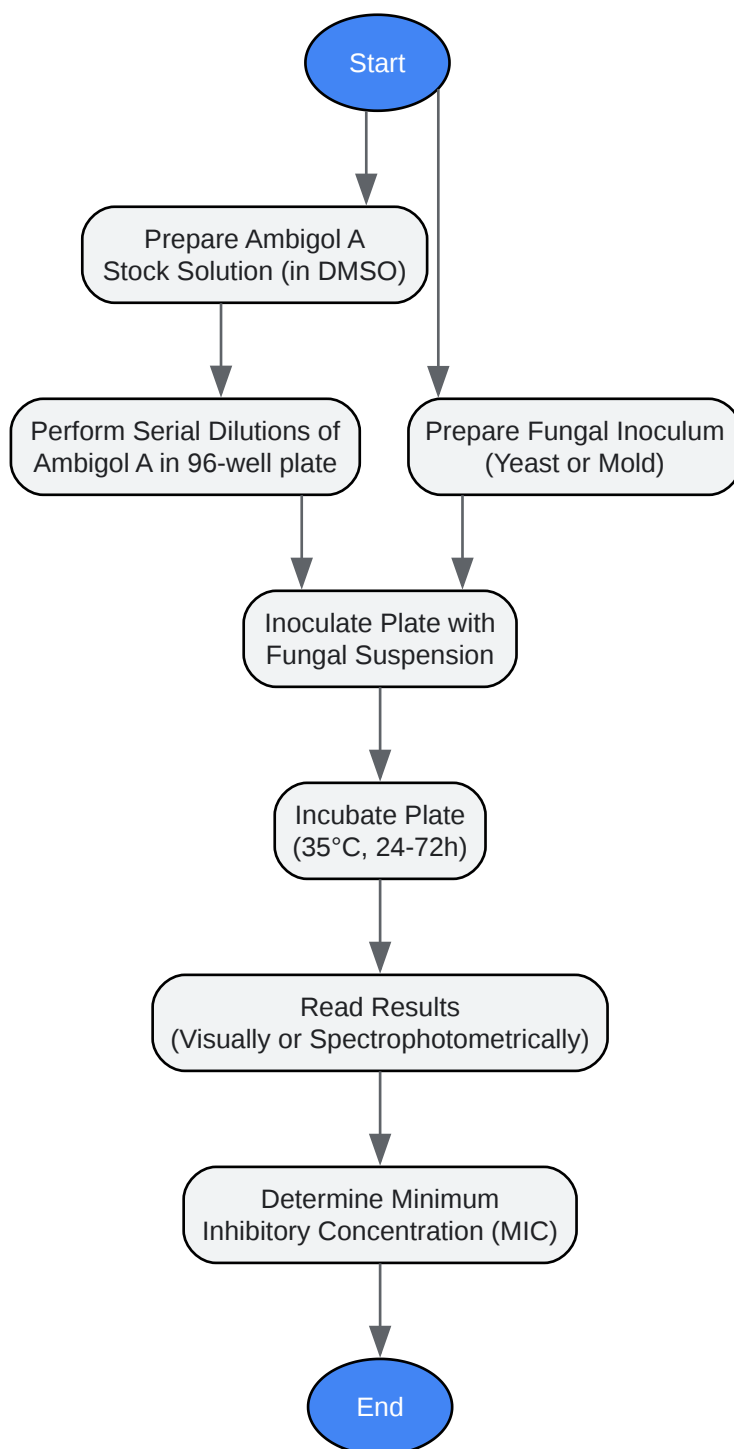

[Click to download full resolution via product page](#)

Caption: Broth microdilution workflow for **Ambigol A**.

Logical Relationship of Key Experimental Components

This diagram outlines the logical connections between the key components involved in the antifungal susceptibility testing of **Ambigol A**.

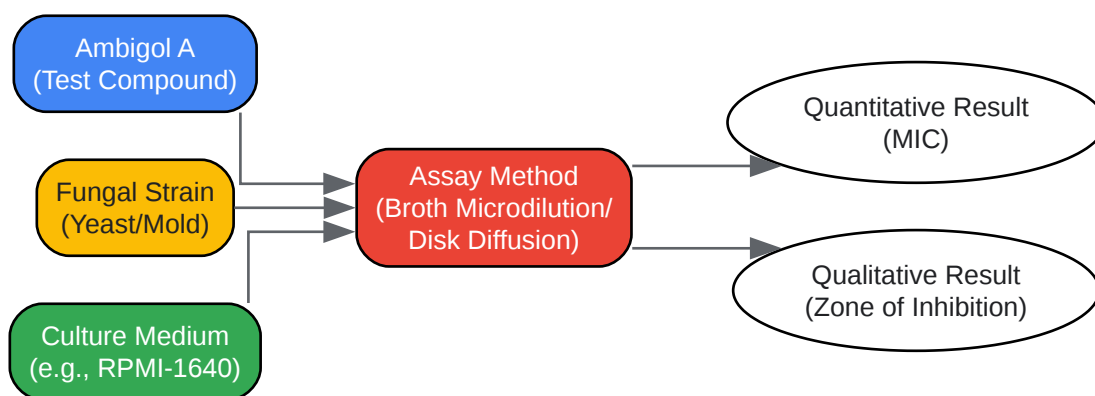

[Click to download full resolution via product page](#)

Caption: Key components of **Ambigol A** antifungal testing.

Need Custom Synthesis?

BenchChem offers custom synthesis for rare earth carbides and specific isotopic labeling.

Email: info@benchchem.com or [Request Quote Online](#).

References

- [1. Antifungal susceptibility testing - PMC \[pmc.ncbi.nlm.nih.gov\]](#)
- [2. researchgate.net \[researchgate.net\]](#)
- [3. A Practical Guide to Antifungal Susceptibility Testing - PMC \[pmc.ncbi.nlm.nih.gov\]](#)
- [4. researchgate.net \[researchgate.net\]](#)
- [5. Broth Microdilution In Vitro Screening: An Easy and Fast Method to Detect New Antifungal Compounds - PMC \[pmc.ncbi.nlm.nih.gov\]](#)

- [6. researchgate.net \[researchgate.net\]](https://www.researchgate.net)
- To cite this document: BenchChem. [Application Notes and Protocols for Antifungal Susceptibility Testing of Ambigol A]. BenchChem, [2026]. [Online PDF]. Available at: [<https://www.benchchem.com/product/b124824/docs#application-notes-and-protocols-for-antifungal-susceptibility-testing-of-ambigol-a>]

Disclaimer & Data Validity:

The information provided in this document is for Research Use Only (RUO) and is strictly not intended for diagnostic or therapeutic procedures. While BenchChem strives to provide accurate protocols, we make no warranties, express or implied, regarding the fitness of this product for every specific experimental setup.

Technical Support: The protocols provided are for reference purposes. Unsure if this reagent suits your experiment?

Need Industrial/Bulk Grade? [Request Custom Synthesis Quote](#)

BenchChem

Our mission is to be the trusted global source of essential and advanced chemicals, empowering scientists and researchers to drive progress in science and industry.

Contact

Address: 3281 E Guasti Rd

Ontario, CA 91761, United States

Phone: (601) 213-4426

Email: info@benchchem.com

[Contact our Ph.D. Support Team for a compatibility check](#)