

Application Notes and Protocols: 3,5-Diacetylpyrazole in the Development of Functional Polymers

Author: BenchChem Technical Support Team. **Date:** May 2026

Compound of Interest

Compound Name: 3,5-Diacetylpyrazole

CAS No.: 98276-70-1

Cat. No.: B124836

[Get Quote](#)

Abstract

The pyrazole nucleus, a five-membered aromatic heterocycle with two adjacent nitrogen atoms, is a privileged scaffold in medicinal chemistry and materials science.[1][2] Its derivatives are integral to the development of functional polymers, imparting desirable thermal, optical, and chelating properties.[3][4] This document provides a detailed guide for researchers on the synthesis and potential applications of 3,5-diacetyl-1H-pyrazole as a versatile monomer for creating novel functional polymers. While direct literature on the polymerization of **3,5-diacetylpyrazole** is nascent, this guide extrapolates from the well-established chemistry of pyrazoles and dicarbonyl compounds to provide robust, scientifically-grounded protocols and application insights. We will detail a proposed synthesis of the monomer, its prospective polymerization into poly(pyrazole-imine)s, and the anticipated properties and applications of the resulting materials, particularly in the realm of metal chelation and thermally stable plastics.

Introduction: The Rationale for 3,5-Diacetylpyrazole in Polymer Science

Functional polymers, materials with tailored chemical and physical properties for specific applications, are at the forefront of materials innovation.[5] The incorporation of heterocyclic moieties, such as pyrazole, into polymer backbones is a strategic approach to imbue these materials with unique functionalities.[6] The pyrazole ring system is characterized by its thermal stability, coordination capabilities with metal ions, and diverse reactivity.[7]

3,5-Diacetyl-1H-pyrazole presents itself as a compelling, yet underexplored, monomer for functional polymer synthesis. Its key features include:

- **Bifunctionality:** The two acetyl groups at the 3 and 5 positions serve as reactive handles for polymerization, particularly through condensation reactions.
- **Rigid Aromatic Core:** The pyrazole ring provides a rigid, thermally stable segment within the polymer backbone.
- **Inherent Chelating Sites:** The two nitrogen atoms of the pyrazole ring can act as coordination sites for metal ions.

This guide will provide the foundational knowledge and experimental protocols to explore the potential of **3,5-diacetylpyrazole** in creating a new class of functional polymers.

Synthesis of the 3,5-Diacetyl-1H-pyrazole Monomer

The synthesis of 3,5-disubstituted pyrazoles is typically achieved through the condensation of a 1,3-dicarbonyl compound with hydrazine.[8] For 3,5-diacetyl-1H-pyrazole, the logical precursor is 2,4,6-heptanetrione.

Proposed Synthetic Pathway

The synthesis can be conceptualized as a two-step process: first, the preparation of the 2,4,6-heptanetrione precursor, followed by its cyclization with hydrazine.

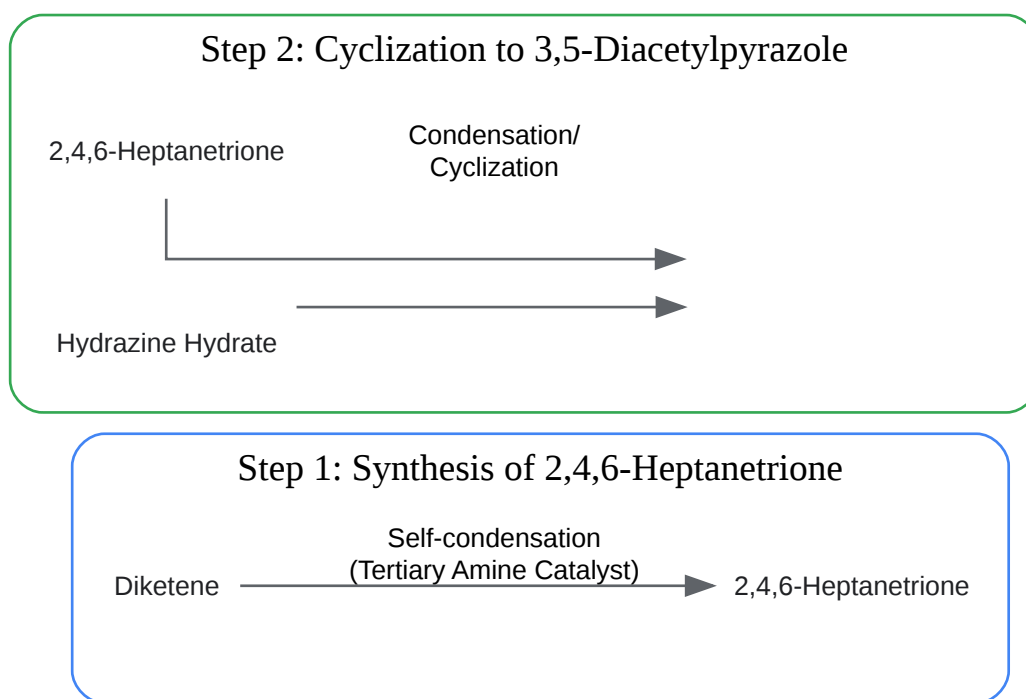

[Click to download full resolution via product page](#)

Caption: Proposed synthesis of 3,5-diacetyl-1H-pyrazole.

Experimental Protocols

Protocol 2.2.1: Synthesis of 2,4,6-Heptanetrione

Causality: This protocol is adapted from a known method for preparing 2,4,6-heptanetrione, which is useful as a chemical intermediate and chelating agent.[9] The self-condensation of diketene is catalyzed by a tertiary amine.

- Reactor Setup: Charge a reactor with deionized water and a tertiary amine catalyst (e.g., 1,4-diazabicyclo[2.2.2]octane or triethylamine).
- Reagent Addition: While maintaining the temperature between 28-30°C, slowly add diketene to the reactor.
- Reaction: After the addition is complete, continue stirring at 30°C for approximately 24 hours.

- Workup: Remove low-boiling byproducts under reduced pressure. The resulting mixture contains 2,4,6-heptanetrione and 2,6-dimethyl-4-pyranone.
- Purification: Separate the 2,4,6-heptanetrione by fractional recrystallization from a suitable solvent such as cyclohexane.

Protocol 2.2.2: Synthesis of 3,5-Diacetyl-1H-pyrazole

Causality: This protocol is based on the general and highly efficient method of pyrazole synthesis from 1,3-dicarbonyl compounds and hydrazine.[8] The reaction proceeds via a condensation-cyclization cascade.

- Dissolution: Dissolve 2,4,6-heptanetrione (1.0 eq) in a suitable solvent such as ethanol or glacial acetic acid in a round-bottom flask equipped with a reflux condenser.
- Hydrazine Addition: Add hydrazine hydrate (1.0-1.2 eq) dropwise to the solution at room temperature with stirring. An exothermic reaction may be observed.
- Reflux: Heat the reaction mixture to reflux for 2-4 hours. Monitor the reaction progress by Thin Layer Chromatography (TLC).
- Isolation: After completion, cool the reaction mixture to room temperature. If a precipitate forms, collect it by filtration. If no precipitate forms, concentrate the solution under reduced pressure.
- Purification: Recrystallize the crude product from a suitable solvent (e.g., ethanol/water mixture) to yield pure 3,5-diacetyl-1H-pyrazole.
- Characterization: Confirm the structure using ^1H NMR, ^{13}C NMR, FT-IR, and mass spectrometry.

Expected ¹ H NMR (CDCl ₃ , 400 MHz)	Chemical Shift (δ, ppm)	Multiplicity	Integration	Assignment
~10.0-12.0	br s	1H	NH (pyrazole)	
~6.8	s	1H	CH (pyrazole)	
~2.6	s	6H	2 x COCH ₃	

Table 1: Predicted ¹H NMR spectral data for 3,5-diacetyl-1H-pyrazole.

Polymerization of 3,5-Diacetylpyrazole: Poly(pyrazole-imine)s

The dual acetyl groups of **3,5-diacetylpyrazole** make it an ideal candidate for condensation polymerization with diamines to form poly(pyrazole-imine)s, also known as poly-Schiff bases. These polymers are known for their thermal stability, chemical resistance, and coordinating properties.[10]

Proposed Polymerization Reaction

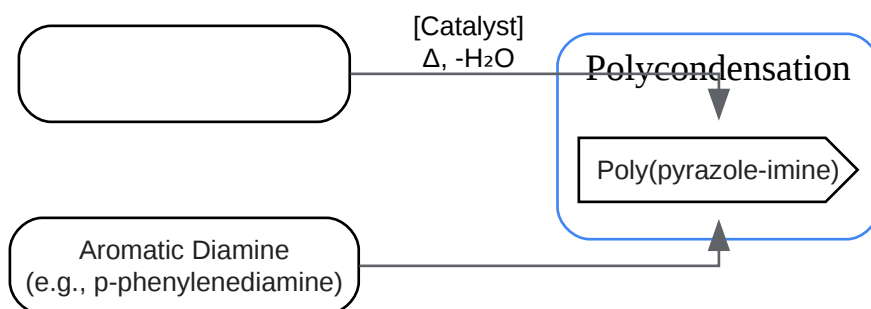

[Click to download full resolution via product page](#)

Caption: Proposed polycondensation of **3,5-diacetylpyrazole** with a diamine.

Experimental Protocol for Poly(pyrazole-imine) Synthesis

Causality: This protocol is a general procedure for the synthesis of poly-Schiff bases from diketones and diamines. The reaction is typically carried out in a high-boiling polar aprotic solvent to facilitate the removal of water and drive the reaction to completion.

- **Monomer Preparation:** In a three-necked flask equipped with a mechanical stirrer, a nitrogen inlet, and a Dean-Stark trap with a condenser, dissolve equimolar amounts of 3,5-diacetyl-1H-pyrazole and an aromatic diamine (e.g., p-phenylenediamine, 4,4'-oxydianiline) in a solvent such as N-methyl-2-pyrrolidone (NMP) or dimethylacetamide (DMAc).
- **Catalyst Addition:** Add a catalytic amount of an acid catalyst, such as p-toluenesulfonic acid (p-TSA), to the reaction mixture.
- **Polymerization:** Heat the mixture to 160-180°C with continuous stirring under a nitrogen atmosphere. The water formed during the reaction is removed azeotropically.
- **Monitoring:** Monitor the viscosity of the reaction mixture. A significant increase in viscosity indicates polymer formation. The reaction is typically continued for 12-24 hours.
- **Precipitation and Isolation:** After cooling to room temperature, pour the viscous polymer solution into a non-solvent such as methanol or water with vigorous stirring. The polymer will precipitate.
- **Purification:** Collect the polymer by filtration, wash it thoroughly with the non-solvent to remove unreacted monomers and catalyst, and then dry it in a vacuum oven at 80-100°C to a constant weight.

Anticipated Properties and Applications

The resulting poly(pyrazole-imine)s are expected to be functional materials with a range of valuable properties.

Metal Chelation

Causality: The polymer backbone contains multiple nitrogen atoms from the pyrazole rings and the imine linkages, creating excellent chelating sites for metal ions.[\[11\]](#)

- **Applications:**

- Environmental Remediation: Removal of heavy metal ions (e.g., Cu^{2+} , Ni^{2+} , Co^{2+} , Pb^{2+}) from wastewater.[12]
- Catalysis: Immobilization of metal catalysts for heterogeneous catalysis, allowing for easy recovery and reuse of the catalyst.
- Sensors: Development of colorimetric or fluorescent sensors for specific metal ions.

Protocol 4.1.1: Evaluation of Metal Ion Uptake

- Stock Solutions: Prepare standard solutions of various metal salts (e.g., CuSO_4 , NiCl_2 , $\text{Co}(\text{NO}_3)_2$) in deionized water.
- Batch Adsorption: Suspend a known mass of the polymer in a known volume of the metal ion solution of a specific concentration.
- Equilibration: Shake the mixture for a predetermined time at a constant temperature to reach equilibrium.
- Analysis: Separate the polymer by filtration or centrifugation. Analyze the concentration of the metal ion remaining in the supernatant using techniques such as Atomic Absorption Spectroscopy (AAS) or Inductively Coupled Plasma-Optical Emission Spectrometry (ICP-OES).
- Calculation: Calculate the amount of metal ion adsorbed per unit mass of the polymer.

Thermal Stability

Causality: The polymer backbone is composed of rigid aromatic pyrazole rings and aromatic diamine units, which are known to impart high thermal stability.

- Applications:
 - High-Performance Plastics: Use as a component in blends or composites for applications requiring high-temperature resistance.
 - Coatings and Adhesives: Formulation of thermally stable coatings and adhesives for aerospace and electronics industries.

Characterization of Thermal Properties

Technique	Information Obtained
Thermogravimetric Analysis (TGA)	Determines the decomposition temperature and thermal stability of the polymer.
Differential Scanning Calorimetry (DSC)	Identifies the glass transition temperature (T _g), indicating the polymer's operational temperature range.

Table 2: Standard techniques for thermal characterization of polymers.

Characterization of 3,5-Diacetylpyrazole-Based Polymers

A thorough characterization is essential to confirm the structure and properties of the synthesized polymers.

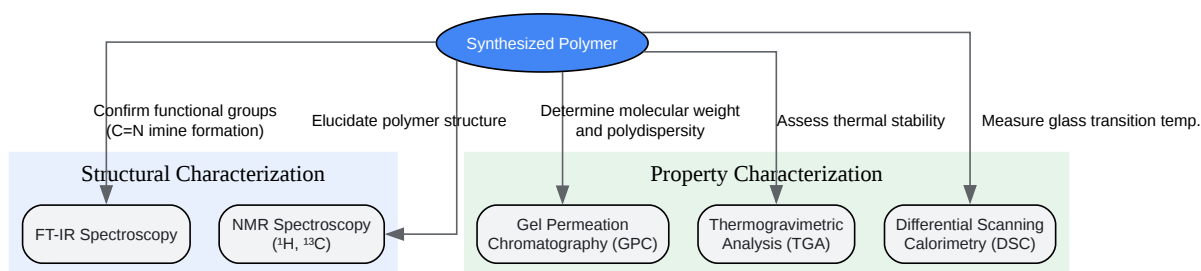

[Click to download full resolution via product page](#)

Caption: Workflow for the characterization of poly(pyrazole-imine)s.

- FT-IR Spectroscopy: Confirmation of polymerization will be evident by the appearance of a characteristic C=N stretching vibration for the imine bond (typically around 1620-1650 cm⁻¹)

and the disappearance of the C=O stretching of the acetyl groups and the N-H stretching of the primary amine.

- NMR Spectroscopy: Due to the often limited solubility of these rigid polymers, solid-state NMR might be necessary. Solution NMR of soluble fractions or oligomers can provide detailed structural information.
- Gel Permeation Chromatography (GPC): To determine the average molecular weight and molecular weight distribution of the polymer, if a suitable solvent can be found.
- Thermogravimetric Analysis (TGA): To evaluate the thermal stability by measuring the weight loss as a function of temperature.
- Differential Scanning Calorimetry (DSC): To determine the glass transition temperature (T_g), which is a critical parameter for understanding the mechanical properties of the polymer at different temperatures.

Conclusion

3,5-Diacetyl-1H-pyrazole holds significant promise as a building block for the next generation of functional polymers. The protocols and insights provided in this guide offer a solid foundation for researchers to synthesize this monomer and explore its polymerization into novel materials with tailored properties. The anticipated high thermal stability and excellent metal-chelating capabilities of poly(pyrazole-imine)s derived from this monomer make them attractive candidates for a wide range of applications in environmental science, catalysis, and advanced materials. Further research in this area is highly encouraged to fully unlock the potential of this versatile pyrazole-based monomer.

References

- Faria, J. V., et al. (2017). Pyrazole-based compounds as platforms for the development of new drugs. *Mini-Reviews in Medicinal Chemistry*, 17(11), 947-960.
- Trofimov, B. A., & Schmidt, A. F. (2018). The chemistry of pyrazole: recent advances. *Molecules*, 23(4), 745.
- Zhang, Y., et al. (2019). Pyrazole-containing polymers: synthesis, properties, and applications. *Polymer Chemistry*, 10(42), 5709-5731.
- Gao, C., & Yan, D. (2011). Hyperbranched polymers: from synthesis to applications. *Progress in Polymer Science*, 36(6), 719-761.

- Roy, N., et al. (2015). Functional polymers: a new avenue for material science. RSC Advances, 5(104), 85679-85701.
- Theato, P. (2008). Synthesis of functional polymers. Journal of Polymer Science Part A: Polymer Chemistry, 46(20), 6677-6687.
- Elguero, J. (1996). Pyrazoles.
- Kumar, V., & Aggarwal, R. (2013). An overview on pyrazole and its biological importance. International Journal of Pharmaceutical Sciences and Research, 4(12), 4544.
- Harris, T. M., & Harris, C. M. (1982). The 1,3,5-triketones. Organic Reactions, 17, 155-211.
- Kim, S., et al. (2017). Poly(Schiff base)s: synthesis, properties, and applications. Progress in Polymer Science, 74, 1-38.
- Kandil, S. A., & El-Sayed, A. M. (2007). Synthesis and characterization of new Schiff base polymers and their metal complexes. European Polymer Journal, 43(5), 1879-1887.
- Ge, H., et al. (2012). A novel Schiff base-functionalized magnetic composite adsorbent for the removal of heavy metal ions from aqueous solution.

Need Custom Synthesis?

BenchChem offers custom synthesis for rare earth carbides and specific isotopic labeling.

Email: info@benchchem.com or [Request Quote Online](#).

Sources

- 1. Pyrazolone-based metal complexes: synthesis, characterization and theoretical study of Zn(II), Cu(II) and Mo(IV) derivatives [[tesisdottorato.depositolegale.it](https://www.tesisdottorato.depositolegale.it)]
- 2. [researchgate.net](https://www.researchgate.net) [[researchgate.net](https://www.researchgate.net)]
- 3. [yavuzlab.com](https://www.yavuzlab.com) [[yavuzlab.com](https://www.yavuzlab.com)]
- 4. [scispace.com](https://www.scispace.com) [[scispace.com](https://www.scispace.com)]
- 5. [jocpr.com](https://www.jocpr.com) [[jocpr.com](https://www.jocpr.com)]
- 6. Synthesis, characterization and biological studies of pyrazole-linked Schiff bases and their copper(ii) complexes as potential therapeutics - PMC [[pmc.ncbi.nlm.nih.gov](https://pubmed.ncbi.nlm.nih.gov)]
- 7. Chelation properties of poly(β -diketone) polymer and its oxime toward heavy metal ions | Semantic Scholar [[semanticscholar.org](https://www.semanticscholar.org)]
- 8. US3374246A - Preparation of 2, 4, 6-heptanetrione and 2, 6-dimethyl-4-pyranone - Google Patents [patents.google.com]

- [9. Discovery of New Schiff Bases Tethered Pyrazole Moiety: Design, Synthesis, Biological Evaluation, and Molecular Docking Study as Dual Targeting DHFR/DNA Gyrase Inhibitors with Immunomodulatory Activity - PMC \[pmc.ncbi.nlm.nih.gov\]](#)
- [10. researchgate.net \[researchgate.net\]](#)
- [11. Recent Developments in Reactions and Catalysis of Protic Pyrazole Complexes - PMC \[pmc.ncbi.nlm.nih.gov\]](#)
- [12. Synthesis of 3- and 5-formyl-4-phenyl-1H-pyrazoles: promising head units for the generation of asymmetric imine ligands and mixed metal polynuclear complexes - New Journal of Chemistry \(RSC Publishing\) \[pubs.rsc.org\]](#)
- To cite this document: BenchChem. [Application Notes and Protocols: 3,5-Diacetylpyrazole in the Development of Functional Polymers]. BenchChem, [2026]. [Online PDF]. Available at: [\[https://www.benchchem.com/product/b124836/docs#application-notes-and-protocols-3-5-diacetylpyrazole-in-the-development-of-functional-polymers\]](https://www.benchchem.com/product/b124836/docs#application-notes-and-protocols-3-5-diacetylpyrazole-in-the-development-of-functional-polymers)

Disclaimer & Data Validity:

The information provided in this document is for Research Use Only (RUO) and is strictly not intended for diagnostic or therapeutic procedures. While BenchChem strives to provide accurate protocols, we make no warranties, express or implied, regarding the fitness of this product for every specific experimental setup.

Technical Support: The protocols provided are for reference purposes. Unsure if this reagent suits your experiment?

Need Industrial/Bulk Grade? [Request Custom Synthesis Quote](#)

BenchChem

Our mission is to be the trusted global source of essential and advanced chemicals, empowering scientists and researchers to drive progress in science and industry.

Contact

Address: 3281 E Guasti Rd
Ontario, CA 91761, United States
Phone: (601) 213-4426
Email: info@benchchem.com

Contact our Ph.D. Support Team for a compatibility check