

Technical Support Center: NAMPT Inhibitors

Author: BenchChem Technical Support Team. **Date:** April 2026

Compound of Interest

Compound Name: *Nampt-IN-9*

Cat. No.: *B12399594*

[Get Quote](#)

Disclaimer: Information regarding the specific off-target effects and toxicity of **Nampt-IN-9** is not available in the public domain based on a comprehensive search. The following troubleshooting guides and FAQs address the known off-target effects and toxicities associated with the broader class of Nicotinamide Phosphoribosyltransferase (NAMPT) inhibitors. Researchers working with **Nampt-IN-9** should consider these as potential class-wide effects and are advised to conduct thorough in-house safety and selectivity profiling.

Frequently Asked Questions (FAQs)

Q1: What are the most common dose-limiting toxicities observed with NAMPT inhibitors in preclinical and clinical studies?

A1: The most significant and consistently reported dose-limiting toxicity for NAMPT inhibitors is thrombocytopenia (a low platelet count).[1] This is considered an on-target effect due to the reliance of hematopoietic progenitor cells on the NAD⁺ salvage pathway. Other hematological toxicities such as anemia and neutropenia have also been observed, particularly at higher doses.[1]

Q2: Are there any other major organ-related toxicities associated with NAMPT inhibitors?

A2: Yes, preclinical studies in rodent models have identified potential for retinal and cardiac toxicities.[1][2] Retinal toxicity, characterized by degeneration of the photoreceptor and outer nuclear layers, has been a concern with some NAMPT inhibitors.[2] While not consistently reported in clinical trials, these findings warrant careful monitoring in preclinical development. Some inhibitors, like OT-82, have been reported to lack these specific toxicities in preclinical studies.[1]

Q3: What is the underlying mechanism of these on-target toxicities?

A3: NAMPT is the rate-limiting enzyme in the NAD⁺ salvage pathway, which is crucial for maintaining cellular NAD⁺ levels.[1] NAD⁺ is an essential cofactor for numerous cellular processes, including energy metabolism and DNA repair.[3] Inhibition of NAMPT leads to NAD⁺ depletion, which can induce apoptosis (programmed cell death), particularly in highly metabolic and proliferating cells such as cancer cells and hematopoietic precursors.[4]

Q4: Can the toxicities of NAMPT inhibitors be mitigated?

A4: Co-administration of nicotinic acid (NA) has been explored as a strategy to mitigate on-target toxicities.[5] NA can be utilized by the Preiss-Handler pathway to generate NAD⁺, thus bypassing the NAMPT-dependent salvage pathway in healthy tissues.[6] While this approach has shown promise in reducing thrombocytopenia in some preclinical models, it has been reported to fail in rescuing retinal toxicity and can also compromise the anti-tumor efficacy of the NAMPT inhibitor, particularly in tumors that are deficient in the Preiss-Handler pathway enzyme, NAPRT1.[5]

Q5: Are there known off-target effects of NAMPT inhibitors?

A5: While many NAMPT inhibitors are highly selective, the potential for off-target effects exists and can be compound-specific. Some observed cytotoxicities in NAPRT-positive cell lines that are resistant to NAMPT inhibition might be attributable to off-target effects of certain inhibitors.[3] Comprehensive kinase profiling and other selectivity screens are essential to characterize the off-target profile of a new chemical entity like **Nampt-IN-9**.

Troubleshooting Guides

Problem 1: Unexpectedly high cytotoxicity in normal or non-cancerous cell lines.

- Possible Cause: This could be due to on-target toxicity in cell types highly dependent on the NAD⁺ salvage pathway, or it could be an indication of off-target effects.
- Troubleshooting Steps:
 - Perform a nicotinic acid (NA) rescue experiment: Supplement the cell culture medium with NA. If the cytotoxicity is on-target (due to NAMPT inhibition), NA should rescue the cells by providing an alternative route for NAD⁺ synthesis.
 - Measure intracellular NAD⁺ levels: Confirm that the inhibitor is depleting NAD⁺ in the sensitive cell lines.
 - Conduct selectivity profiling: Screen the inhibitor against a panel of kinases and other relevant enzymes to identify potential off-target interactions.

Problem 2: In vivo studies show significant weight loss and signs of distress in animal models at doses required for anti-tumor efficacy.

- Possible Cause: This is likely due to on-target toxicities, such as hematological or gastrointestinal effects, stemming from NAD⁺ depletion in healthy tissues.
- Troubleshooting Steps:
 - Monitor complete blood counts (CBCs): Regularly check for thrombocytopenia, anemia, and neutropenia.
 - Evaluate co-administration with nicotinic acid: Test if NA can ameliorate the toxicity without compromising efficacy in your specific tumor model. This is highly dependent on the NAPRT1 status of the tumor.
 - Histopathological analysis: At the end of the study, perform a thorough histological examination of major organs, with a particular focus on the retina, heart, and bone marrow, to identify any compound-related pathologies.

Quantitative Data Summary

Table 1: Overview of Toxicities Associated with NAMPT Inhibitors (Class-wide Effects)

Toxicity Type	Observation	Species	Notes
Hematological			
Thrombocytopenia	Dose-limiting toxicity	Human, Rodent	On-target effect[1]
Anemia	Observed at high doses	Rodent	On-target effect[1]
Neutropenia	Observed at high doses	Rodent	On-target effect[1]
Ocular			
Retinopathy	Degeneration of photoreceptor and outer nuclear layers	Rodent	On-target effect, not consistently rescued by NA[2][5]
Cardiovascular			
Cardiac Toxicity	Suggested as a potential dose-limiting side effect in preclinical studies	Rodent	[1]

Experimental Protocols

Protocol 1: In Vitro Nicotinic Acid (NA) Rescue Assay

- Cell Plating: Seed cells of interest (both tumor and normal cell lines) in a 96-well plate at a predetermined optimal density.
- Compound Treatment: Treat the cells with a serial dilution of the NAMPT inhibitor (e.g., **Nampt-IN-9**) in the presence or absence of a fixed concentration of nicotinic acid (typically 1-10 μ M).
- Incubation: Incubate the plates for a period that is sufficient to observe cytotoxicity (e.g., 72-96 hours).

- **Viability Assessment:** Measure cell viability using a standard method such as a resazurin-based assay or CellTiter-Glo®.
- **Data Analysis:** Compare the dose-response curves of the NAMPT inhibitor with and without NA. A rightward shift in the curve in the presence of NA indicates on-target rescue.

Protocol 2: Assessment of Hematological Toxicity in Rodents

- **Animal Dosing:** Administer the NAMPT inhibitor to mice or rats at various dose levels for a specified duration (e.g., 7-14 days). Include a vehicle control group.
- **Blood Collection:** Collect blood samples (e.g., via retro-orbital or tail vein sampling) at baseline and at multiple time points during the study.
- **Complete Blood Count (CBC) Analysis:** Analyze the blood samples using an automated hematology analyzer to determine platelet counts, red blood cell counts, hemoglobin levels, and neutrophil counts.
- **Data Analysis:** Compare the hematological parameters of the treated groups to the vehicle control group to identify any significant changes.

Visualizations

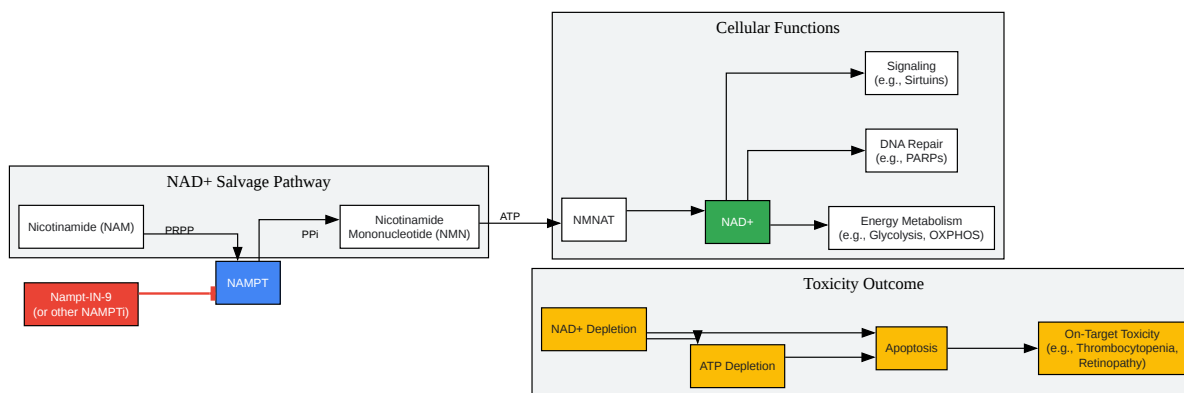

[Click to download full resolution via product page](#)

Caption: Mechanism of on-target toxicity of NAMPT inhibitors.

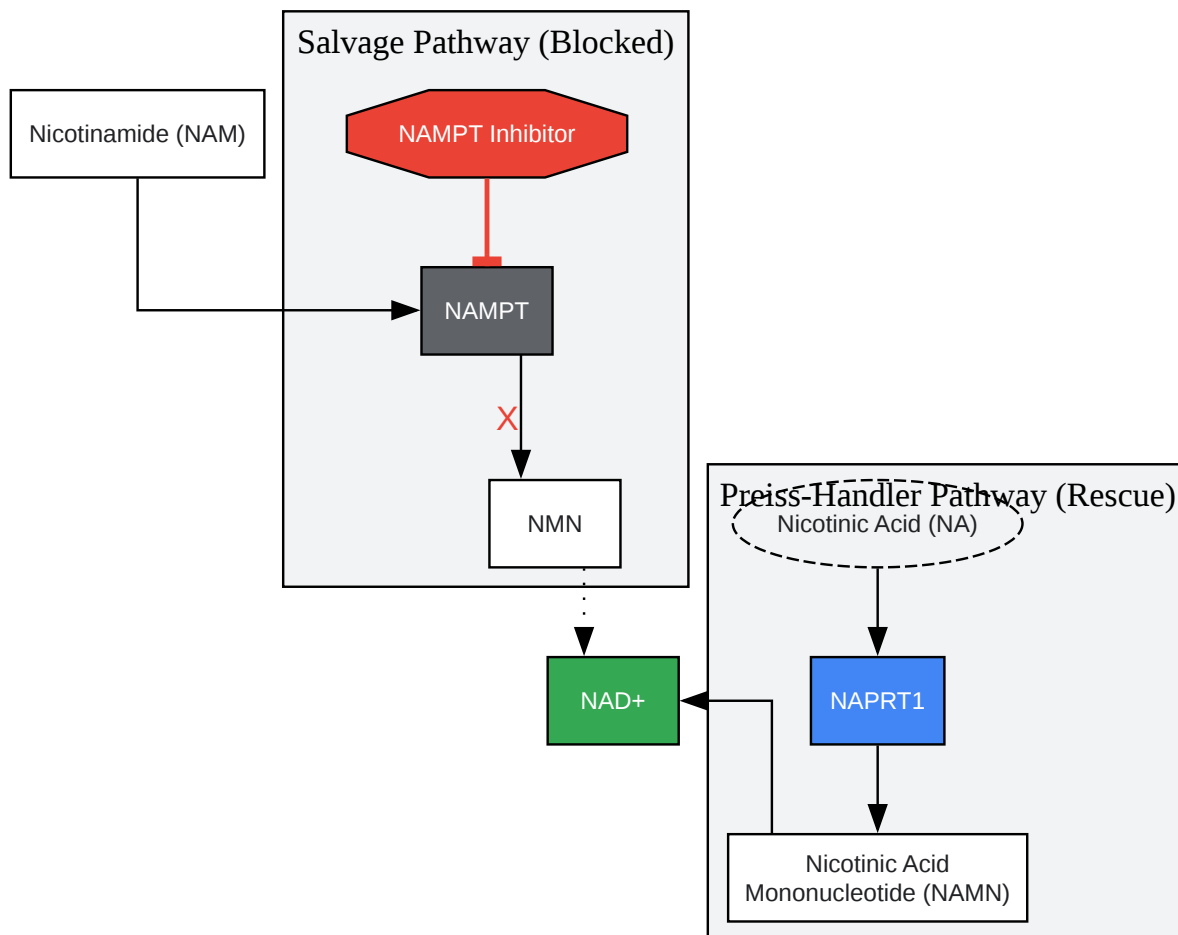

Logical workflow of the nicotinic acid rescue pathway.

[Click to download full resolution via product page](#)

Caption: Nicotinic acid rescue pathway logic.

Need Custom Synthesis?

BenchChem offers custom synthesis for rare earth carbides and specific isotopic labeling.

Email: info@benchchem.com or [Request Quote Online](#).

References

- [1. Recent Advances in NAMPT Inhibitors: A Novel Immunotherapeutic Strategy - PMC \[pmc.ncbi.nlm.nih.gov\]](#)
- [2. academic.oup.com \[academic.oup.com\]](#)
- [3. Discovery of a novel NAMPT inhibitor that selectively targets NAPRT-deficient EMT-subtype cancer cells and alleviates chemotherapy-induced peripheral neuropathy - PMC \[pmc.ncbi.nlm.nih.gov\]](#)
- [4. Frontiers | NAMPT Inhibition Induces Neuroblastoma Cell Death and Blocks Tumor Growth \[frontiersin.org\]](#)
- [5. aacrjournals.org \[aacrjournals.org\]](#)
- [6. pubs.acs.org \[pubs.acs.org\]](#)
- [To cite this document: BenchChem. \[Technical Support Center: NAMPT Inhibitors\]. BenchChem, \[2026\]. \[Online PDF\]. Available at: \[https://www.benchchem.com/product/b12399594/docs#technical-support-center-nampt-inhibitors\]](#)

Disclaimer & Data Validity:

The information provided in this document is for Research Use Only (RUO) and is strictly not intended for diagnostic or therapeutic procedures. While BenchChem strives to provide accurate protocols, we make no warranties, express or implied, regarding the fitness of this product for every specific experimental setup.

Technical Support: The protocols provided are for reference purposes. Unsure if this reagent suits your experiment?

Need Industrial/Bulk Grade? [Request Custom Synthesis Quote](#)

BenchChem

Our mission is to be the trusted global source of essential and advanced chemicals, empowering scientists and researchers to drive progress in science and industry.

Contact

Address: 3281 E Guasti Rd

Ontario, CA 91761, United States

Phone: (601) 213-4426

Email: info@benchchem.com

Contact our Ph.D. Support Team for a compatibility check