

Technical Guide: Mechanism of Action of GABAA Receptor Agent 5

Author: BenchChem Technical Support Team. **Date:** April 2026

Compound of Interest

Compound Name: GABAA receptor agent 5

Cat. No.: B12399267

[Get Quote](#)

Audience: Researchers, Scientists, and Drug Development Professionals

Abstract: The γ -aminobutyric acid type A (GABAA) receptor is the primary mediator of fast inhibitory neurotransmission in the central nervous system (CNS) and a validated target for a wide range of therapeutic agents.[1][2] Dysfunction of the GABAergic system is implicated in numerous neurological and psychiatric disorders.[1][3] This document provides a detailed technical overview of the mechanism of action of a novel investigational compound, referred to herein as Agent 5, a positive allosteric modulator (PAM) of the GABAA receptor. We will delineate its interaction with the receptor, present its pharmacological profile through quantitative data, describe the experimental methodologies used for its characterization, and illustrate key pathways and workflows.

Introduction to GABAA Receptors

GABAA receptors are ligand-gated ion channels belonging to the Cys-loop superfamily.[4] These receptors are pentameric structures assembled from a selection of 19 different subunits (e.g., α , β , γ), forming a central chloride (Cl^-) ion-permeable pore.[1][3][5] The most common isoform in the CNS consists of two α , two β , and one γ subunit.[1][3][6] The binding of the endogenous neurotransmitter GABA to its orthosteric sites, located at the interface between α

and β subunits, triggers a conformational change that opens the channel.[4][7] The subsequent influx of Cl^- ions leads to hyperpolarization of the neuronal membrane, reducing the likelihood of an action potential and thus exerting an inhibitory effect on neurotransmission.[7][8]

Core Mechanism of Action of Agent 5

Agent 5 functions as a positive allosteric modulator (PAM) of the GABAA receptor. Unlike orthosteric agonists that bind directly to the GABA binding site, PAMs bind to a distinct, topographically separate (allosteric) site on the receptor complex.[7][9] This allosteric binding event induces a conformational change in the receptor that enhances the effect of GABA without directly activating the channel in the absence of the endogenous ligand.[7][9]

The primary mechanisms by which Agent 5 potentiates GABAergic currents are:

- **Increased GABA Affinity:** Binding of Agent 5 increases the affinity of the GABA binding sites, meaning that a lower concentration of GABA is required to elicit a response.
- **Enhanced Channel Gating:** Agent 5 increases the probability and/or duration of channel opening when GABA is bound, leading to a greater influx of Cl^- ions for a given level of GABA stimulation.[7]

This modulatory action allows for a fine-tuning of inhibitory neurotransmission rather than a simple on/off activation, preserving the natural temporal and spatial patterns of GABA release.

Signaling Pathway Diagram

The following diagram illustrates the core signaling pathway of the GABAA receptor and the modulatory role of Agent 5.

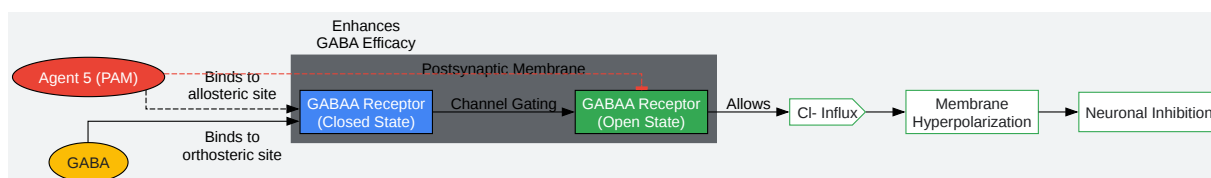

[Click to download full resolution via product page](#)

Caption: GABAA receptor signaling pathway modulated by Agent 5.

Pharmacological Profile of Agent 5

The pharmacological effects of Agent 5 have been quantified through a series of binding and functional assays to determine its affinity, potency, efficacy, and subtype selectivity.

Binding Affinity

The binding affinity of Agent 5 for various GABAA receptor subtypes was determined using radioligand binding assays. The data, presented as inhibitor constant (K_i) values, indicate the concentration of Agent 5 required to displace 50% of a specific radioligand from the receptor. Lower K_i values signify higher binding affinity.

Table 1: Binding Affinity (K_i) of Agent 5 at Human Recombinant GABAA Receptor Subtypes

Receptor Subtype	Radioligand	K_i (nM)
$\alpha 1\beta 2\gamma 2$	[³ H]Flumazenil	25.4
$\alpha 2\beta 3\gamma 2$	[³ H]Flumazenil	3.1
$\alpha 3\beta 3\gamma 2$	[³ H]Flumazenil	4.5

| $\alpha 5\beta 3\gamma 2$ | [³H]Ro15-4513 | 150.8 |

Data are representative and hypothetical.

The data indicate that Agent 5 exhibits significant selectivity, with the highest affinity for receptors containing $\alpha 2$ and $\alpha 3$ subunits. This profile suggests a potential for anxiolytic effects with a reduced sedative and amnestic side-effect profile often associated with $\alpha 1$ and $\alpha 5$ subunit activity, respectively.^{[10][11]}

Functional Potency and Efficacy

The functional activity of Agent 5 was assessed via two-electrode voltage-clamp (TEVC) electrophysiology on *Xenopus laevis* oocytes expressing specific human GABAA receptor subtypes. The potentiation of a submaximal GABA concentration (EC_{20}) was measured.

Table 2: Functional Potentiation of GABA-Evoked Currents by Agent 5

Receptor Subtype	GABA EC_{20} (μM)	Agent 5 EC_{50} (nM)	Max Potentiation (%)
$\alpha 1\beta 2\gamma 2$	1.5	45.2	350
$\alpha 2\beta 3\gamma 2$	5.0	8.9	1250
$\alpha 3\beta 3\gamma 2$	8.2	11.3	1180

| $\alpha 5\beta 3\gamma 2$ | 0.5 | 210.5 | 150 |

Data are representative and hypothetical.

The functional data corroborate the binding profile, demonstrating that Agent 5 is most potent and efficacious at $\alpha 2$ - and $\alpha 3$ -containing receptors. It acts as a strong positive modulator at these subtypes while having significantly weaker effects at $\alpha 1$ - and $\alpha 5$ -containing receptors.

Experimental Protocols

Radioligand Binding Assay Protocol

- Membrane Preparation: Cell membranes from HEK293 cells stably expressing the desired recombinant human GABAA receptor subtype are prepared via homogenization and centrifugation.
- Assay Buffer: The assay is conducted in a buffer solution (e.g., 50 mM Tris-HCl, pH 7.4).

- Incubation: Membranes are incubated with a fixed concentration of a suitable radioligand (e.g., [³H]Flumazenil for the benzodiazepine site) and a range of concentrations of the unlabeled test compound (Agent 5).
- Equilibrium: The mixture is incubated to equilibrium (e.g., 60 minutes at 4°C).
- Separation: Bound and free radioligand are separated by rapid filtration through glass fiber filters.
- Quantification: The radioactivity trapped on the filters is quantified using liquid scintillation counting.
- Data Analysis: Non-specific binding is determined in the presence of a high concentration of a non-radiolabeled ligand (e.g., 10 μM Diazepam). Specific binding is calculated, and IC₅₀ values are determined by non-linear regression. K_i values are then calculated using the Cheng-Prusoff equation.

Two-Electrode Voltage-Clamp (TEVC) Electrophysiology Protocol

- Oocyte Preparation: Oocytes are harvested from *Xenopus laevis* and injected with cRNAs encoding the specific α, β, and γ subunits of the human GABA_A receptor. Oocytes are incubated for 2-5 days to allow for receptor expression.
- Recording: An oocyte is placed in a recording chamber and continuously perfused with recording solution. The oocyte is impaled with two microelectrodes (one for voltage clamping, one for current recording), and the membrane potential is clamped at -70 mV.
- GABA Application: GABA at a predetermined EC₂₀ concentration is applied to establish a baseline current response.
- Compound Application: Following a washout period, Agent 5 is co-applied with the same EC₂₀ concentration of GABA. A range of Agent 5 concentrations are tested to determine a dose-response curve.
- Data Analysis: The potentiation of the GABA-evoked current is calculated as a percentage increase over the baseline GABA response. EC₅₀ values (the concentration of Agent 5 that

produces 50% of its maximal effect) and maximal potentiation are determined by fitting the dose-response data to a sigmoidal function.

Experimental Workflow Diagram

The following diagram outlines the workflow for the characterization of Agent 5's functional activity.

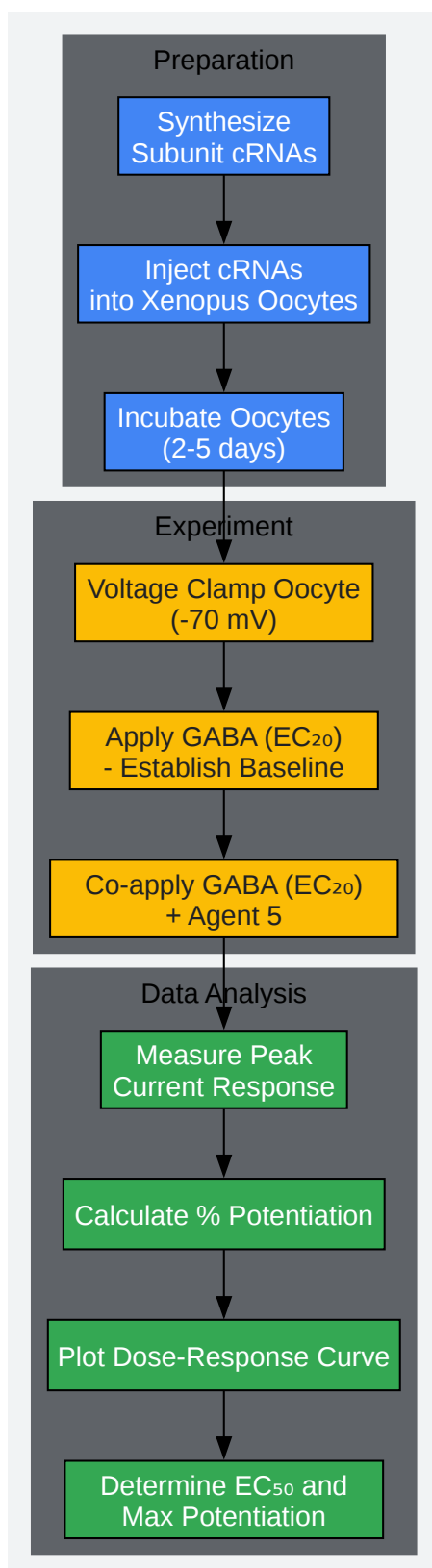

[Click to download full resolution via product page](#)

Caption: Experimental workflow for TEVC electrophysiology.

Logical Mechanism of Action Summary

The sequence of events from the binding of Agent 5 to the ultimate physiological outcome can be summarized logically.

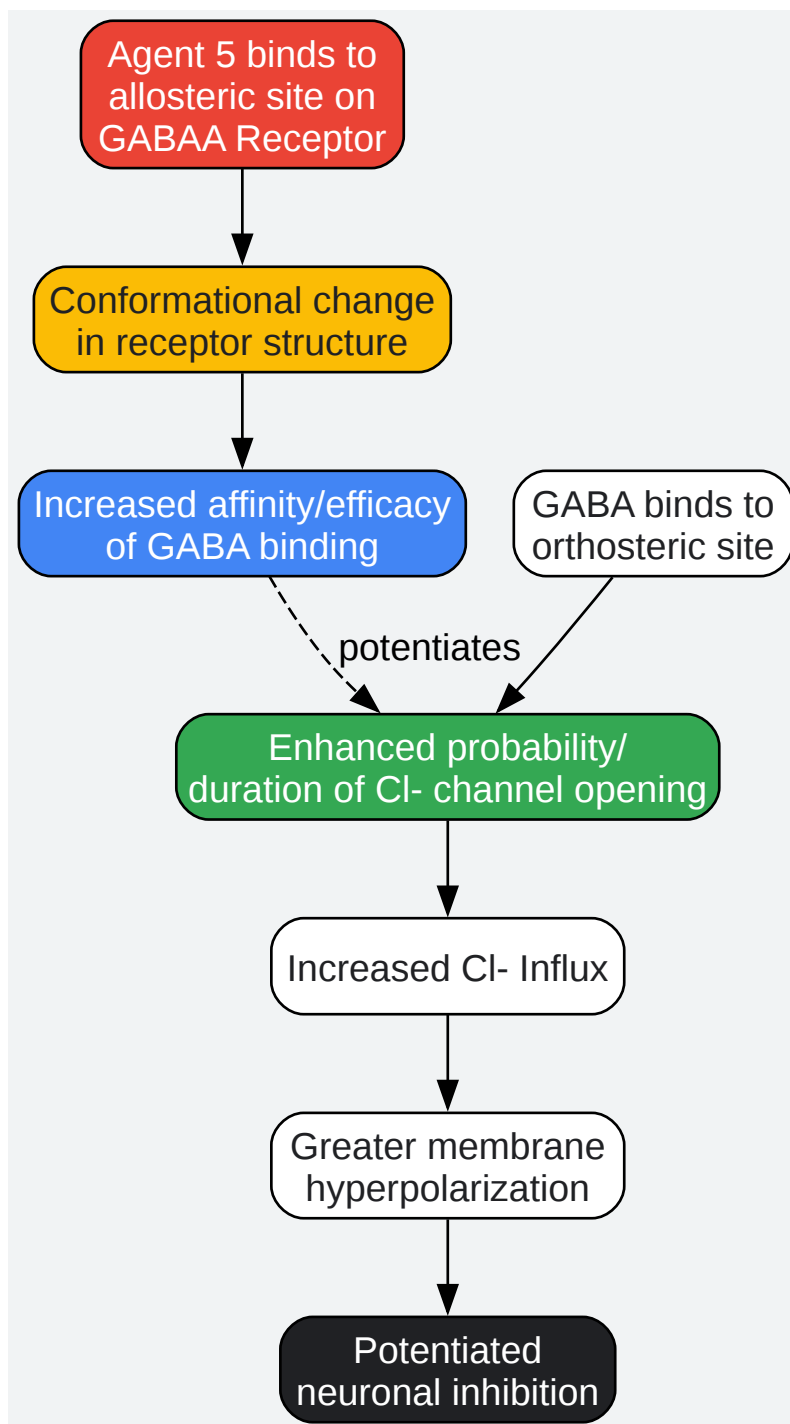

[Click to download full resolution via product page](#)

Caption: Logical flow of Agent 5's mechanism of action.

Conclusion

Agent 5 is a subtype-selective positive allosteric modulator of the GABAA receptor with high potency and efficacy at $\alpha 2$ - and $\alpha 3$ -containing receptor subtypes. Its mechanism of action involves binding to an allosteric site, which enhances the receptor's response to the endogenous neurotransmitter GABA, leading to increased chloride ion influx and potentiated neuronal inhibition. This pharmacological profile suggests that Agent 5 may offer therapeutic benefits for conditions such as anxiety disorders while potentially mitigating the side effects associated with less selective GABAA receptor modulators. Further preclinical and clinical investigations are warranted to fully elucidate its therapeutic potential.

Need Custom Synthesis?

BenchChem offers custom synthesis for rare earth carbides and specific isotopic labeling.

Email: info@benchchem.com or [Request Quote Online](#).

References

- 1. GABAA receptors: structure, function, pharmacology, and related disorders - PMC [[pmc.ncbi.nlm.nih.gov](https://pubmed.ncbi.nlm.nih.gov)]
- 2. Frontiers | Editorial: The GABAA receptor: a target of pharmacologically active molecules [frontiersin.org]
- 3. GABAA receptors: structure, function, pharmacology, and related disorders - PubMed [pubmed.ncbi.nlm.nih.gov]
- 4. GABAA receptor - Wikipedia [en.wikipedia.org]
- 5. researchgate.net [researchgate.net]
- 6. A novel GABAA receptor pharmacology: drugs interacting with the $\alpha + \beta$ - interface - PMC [[pmc.ncbi.nlm.nih.gov](https://pubmed.ncbi.nlm.nih.gov)]
- 7. GABAA receptor positive allosteric modulator - Wikipedia [en.wikipedia.org]
- 8. GABA Receptor Physiology and Pharmacology - Basic Neurochemistry - NCBI Bookshelf [[ncbi.nlm.nih.gov](https://pubmed.ncbi.nlm.nih.gov)]

- [9. What are GABAA receptor positive allosteric modulators and how do they work? \[synapse.patsnap.com\]](#)
- [10. taylorandfrancis.com \[taylorandfrancis.com\]](#)
- [11. researchgate.net \[researchgate.net\]](#)
- To cite this document: BenchChem. [Technical Guide: Mechanism of Action of GABAA Receptor Agent 5]. BenchChem, [2026]. [Online PDF]. Available at: [\[https://www.benchchem.com/product/b12399267/docs#technical-guide-mechanism-of-action-of-gabaa-receptor-agent-5\]](https://www.benchchem.com/product/b12399267/docs#technical-guide-mechanism-of-action-of-gabaa-receptor-agent-5)

Disclaimer & Data Validity:

The information provided in this document is for Research Use Only (RUO) and is strictly not intended for diagnostic or therapeutic procedures. While BenchChem strives to provide accurate protocols, we make no warranties, express or implied, regarding the fitness of this product for every specific experimental setup.

Technical Support: The protocols provided are for reference purposes. Unsure if this reagent suits your experiment?

Need Industrial/Bulk Grade? [Request Custom Synthesis Quote](#)

BenchChem

Our mission is to be the trusted global source of essential and advanced chemicals, empowering scientists and researchers to drive progress in science and industry.

Contact

Address: 3281 E Guasti Rd
Ontario, CA 91761, United States
Phone: (601) 213-4426
Email: info@benchchem.com

[Contact our Ph.D. Support Team for a compatibility check](#)

