

# Technical Support Center: Troubleshooting CCT373567 Toxicity in Animal Models

**Author:** BenchChem Technical Support Team. **Date:** April 2026

## Compound of Interest

Compound Name: CCT373567

Cat. No.: B12398597

[Get Quote](#)

## Introduction

This technical support center is designed for researchers, scientists, and drug development professionals working with the novel multi-targeted kinase inhibitor, **CCT373567**. **CCT373567** is an investigational inhibitor of Vascular Endothelial Growth Factor Receptor (VEGFR), Platelet-Derived Growth Factor Receptor (PDGFR), and Src family kinases. This guide provides troubleshooting advice and frequently asked questions (FAQs) in a question-and-answer format to address specific issues that may be encountered during in vivo animal studies.

## Frequently Asked Questions (FAQs) & Troubleshooting Guides

This section addresses common challenges and questions regarding **CCT373567** toxicity in animal models. Each query is followed by potential causes and actionable troubleshooting steps.

1. What are the expected on-target toxicities of **CCT373567** based on its kinase inhibitory profile?

Given that **CCT373567** inhibits VEGFR, PDGFR, and Src kinases, researchers should anticipate a range of on-target toxicities. Understanding these potential effects is crucial for proactive monitoring and management in preclinical studies.

#### Troubleshooting & Monitoring:

- **Proactive Monitoring:** Based on the target profile, it is essential to proactively monitor for clinical signs and biomarkers associated with the inhibition of VEGFR, PDGFR, and Src kinases.
- **Dose-Response Relationship:** Establishing a clear dose-response relationship for both efficacy and toxicity is critical to identifying a therapeutic window.
- **Histopathology:** Conduct comprehensive histopathological analysis of key organs known to be affected by inhibitors of these pathways, such as the heart, kidneys, liver, and gastrointestinal tract.

2. We are observing significant hypertension and proteinuria in our rodent models. What is the likely cause and how can we manage this?

Hypertension and proteinuria are common on-target toxicities associated with VEGFR inhibition.

#### Potential Causes:

- **VEGFR Inhibition:** Disruption of VEGF signaling in the vasculature and kidneys is the most probable cause.
- **Dose Level:** The administered dose may be too high, leading to excessive VEGFR inhibition.

#### Troubleshooting & Management:

- **Blood Pressure Monitoring:** Implement regular and accurate blood pressure monitoring in conscious animals to establish a baseline and track changes.
- **Urinalysis:** Conduct regular urinalysis to monitor for the presence and severity of proteinuria.

- Dose Adjustment: If hypertension or proteinuria is severe, consider dose reduction or modification of the dosing schedule.
- Supportive Care: Ensure animals have free access to water to maintain hydration.

3. Our animals are exhibiting skin rashes and diarrhea. What could be the underlying reason?

These toxicities are often linked to the inhibition of kinases involved in maintaining the integrity of the skin and gastrointestinal tract.

Potential Causes:

- PDGFR/VEGFR Inhibition: Disruption of signaling in the skin and gastrointestinal tract can lead to these side effects.
- Off-Target Effects: Although less likely to be the primary cause, off-target effects of multi-targeted kinase inhibitors can sometimes contribute.

Troubleshooting & Management:

- Dermatological Scoring: Use a standardized scoring system to grade the severity of skin rashes.
- Supportive Care: For mild to moderate skin toxicities, supportive care such as topical emollients may be considered, though their impact on the study should be evaluated. For diarrhea, ensure adequate hydration and monitor for weight loss.
- Dose Modification: A dose reduction may be necessary if these toxicities are dose-limiting.

4. We have observed unexpected mortality at doses that were previously well-tolerated. What should we investigate?

Unexpected mortality can stem from a variety of factors, including compound formulation, experimental variability, or previously unobserved toxicities.

Potential Causes:

- **Formulation Issues:** Poor solubility or stability of the compound in the dosing vehicle can lead to inconsistent exposure and unexpected toxicity.
- **Animal Health Status:** Underlying health issues in the animal cohort can increase susceptibility to drug-induced toxicity.
- **Experimental Error:** Errors in dose calculation or administration can lead to overdosing.

#### Troubleshooting Steps:

- **Verify Formulation:** Ensure the formulation is prepared correctly and is stable for the duration of the study. Assess the solubility and homogeneity of **CCT373567** in the vehicle.
- **Confirm Dose Calculations:** Double-check all dose calculations and administration volumes.
- **Necropsy and Histopathology:** Conduct a thorough necropsy and histopathological examination of all animals that die unexpectedly to identify the cause of death.
- **Monitor Animal Health:** Closely monitor the health of the animals, including body weight, food and water intake, and clinical signs of toxicity.

## Quantitative Data Summary

The following table summarizes hypothetical dose-dependent toxicities for **CCT373567** observed in preclinical animal models.

Animal Model	Dose Level (mg/kg/day)	Key Observations	Incidence (%)	Severity
Mouse (BALB/c)	25	No significant findings	0	-
50	Mild hypertension, slight body weight loss	40	Mild	
100	Moderate hypertension, significant body weight loss, diarrhea	80	Moderate	
Rat (Sprague-Dawley)	10	No significant findings	0	-
25	Mild proteinuria, slight increase in liver enzymes	30	Mild	
50	Moderate proteinuria, moderate hypertension, skin rashes	70	Moderate to Severe	

## Experimental Protocols

### 1. In Vivo Blood Pressure Monitoring in Rodents

This protocol describes a non-invasive method for measuring blood pressure in conscious rodents using a tail-cuff system.

- **Acclimatization:** Acclimate the animals to the restraining device and tail-cuff for several days before the first measurement.

- Procedure:
  - Place the animal in a restrainer.
  - Position the tail-cuff and pulse sensor on the animal's tail.
  - Allow the animal to calm down for 5-10 minutes.
  - Inflate and deflate the cuff automatically using the system software.
  - Record at least 10-15 consecutive measurements and calculate the average systolic and diastolic blood pressure.
- Frequency: Measure blood pressure at baseline (before treatment) and at regular intervals throughout the study (e.g., weekly).

## 2. Dermatological Toxicity Scoring

A standardized scoring system is essential for the objective assessment of skin toxicities.

- Scoring System:
  - 0: Normal skin
  - 1: Mild erythema (redness)
  - 2: Moderate erythema with scaling
  - 3: Severe erythema, scaling, and crusting
  - 4: Ulceration
- Procedure:
  - Visually inspect the entire body surface of the animal.
  - Assign a score based on the most severe finding.
  - Record the location and extent of the skin lesions.

- Frequency: Perform scoring at least twice a week.

### 3. Histopathological Analysis

Histopathology is crucial for identifying microscopic changes in tissues.

- Tissue Collection: At the end of the study or at the time of necropsy, collect key organs (e.g., liver, kidney, heart, spleen, gastrointestinal tract).
- Fixation: Fix the tissues in 10% neutral buffered formalin.
- Processing: Dehydrate the tissues, embed them in paraffin, and section them at 4-5  $\mu\text{m}$ .
- Staining: Stain the sections with hematoxylin and eosin (H&E).
- Evaluation: A board-certified veterinary pathologist should examine the slides for any pathological changes.

## Visualizations

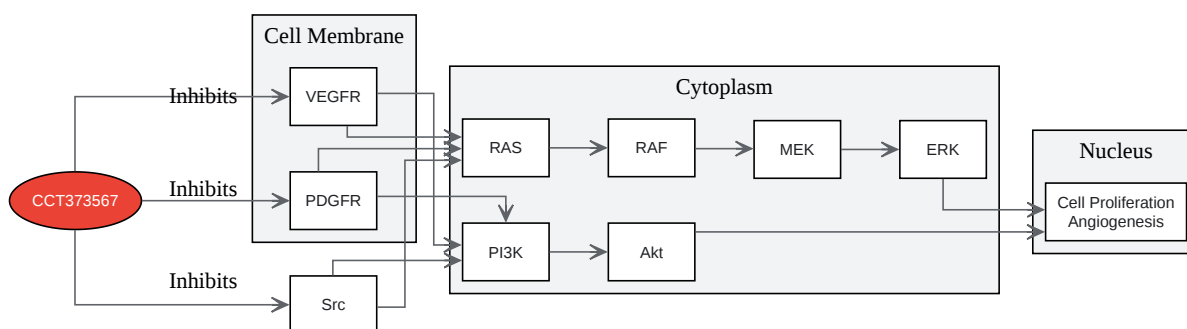

[Click to download full resolution via product page](#)

Caption: Hypothetical signaling pathway inhibited by **CCT373567**.

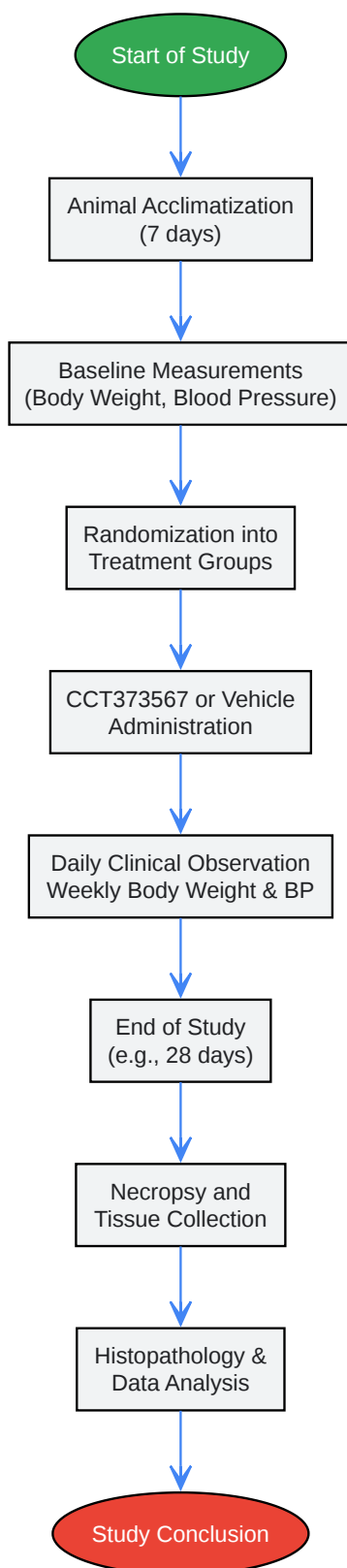

[Click to download full resolution via product page](#)

Caption: General experimental workflow for a toxicity study.

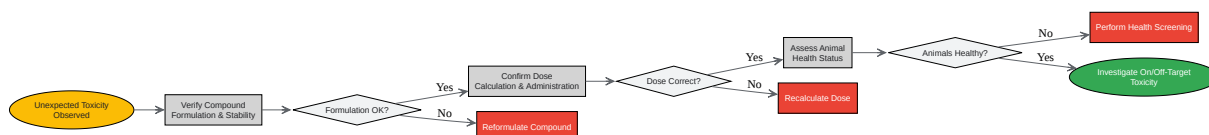

[Click to download full resolution via product page](#)

Caption: Troubleshooting decision tree for unexpected toxicity.

- To cite this document: BenchChem. [Technical Support Center: Troubleshooting CCT373567 Toxicity in Animal Models]. BenchChem, [2026]. [Online PDF]. Available at: [\[https://www.benchchem.com/product/b12398597/docs#technical-support-center-troubleshooting-cct373567-toxicity-in-animal-models\]](https://www.benchchem.com/product/b12398597/docs#technical-support-center-troubleshooting-cct373567-toxicity-in-animal-models)

### Disclaimer & Data Validity:

The information provided in this document is for Research Use Only (RUO) and is strictly not intended for diagnostic or therapeutic procedures. While BenchChem strives to provide accurate protocols, we make no warranties, express or implied, regarding the fitness of this product for every specific experimental setup.

**Technical Support:** The protocols provided are for reference purposes. Unsure if this reagent suits your experiment?

**Need Industrial/Bulk Grade?** [Request Custom Synthesis Quote](#)

# BenchChem

Our mission is to be the trusted global source of essential and advanced chemicals, empowering scientists and researchers to drive progress in science and industry.

## Contact

Address: 3281 E Guasti Rd

Ontario, CA 91761, United States

Phone: (601) 213-4426

Email: [info@benchchem.com](mailto:info@benchchem.com)

[Contact our Ph.D. Support Team for a compatibility check](#)